

## *Article 4. Signs*

### **6.400 Scope**

This Article is enacted to provide uniform standards for the location, spacing, height, lighting, and other regulation of signs within the City of Fort Worth. The purpose of this Article is protect the health, safety, welfare, convenience and enjoyment of the general public and to protect the public from injury which may be caused by the unregulated construction of signs. It is the intent of these regulations to achieve the following:

1. Enhance the economic value of the landscape by avoiding visual clutter which is potentially harmful to property values and business opportunities;
2. Promote the safety of persons and property by providing that signs do not create a hazard, due to collapse, fire, collision, weather or decay;
3. Protect the safety and efficiency of the City's transportation network by reducing the confusion or distraction to motorists and enhancing motorists' ability to see pedestrians, obstacles, other vehicles and traffic signs;
4. Enhance the impression of the City which is conveyed to tourists and visitors;
5. Protect adjacent and nearby properties from the impact of lighting, size, height and location of signs;
6. Preserve, protect and enhance areas of historical, architectural, scenic and aesthetic value, regardless of whether they be cultural, natural or man-made; and
7. Encourage the removal of off-premises signs from designated scenic, cultural, architectural or historic districts or corridors. (Ord. No. 18745, Eff. 8/11/09)

### **6.401 Enforcement**

This Article is adopted with specific reference to the regulations contained in the Fort Worth Sign Code, Chapter 29, City Code, and shall be enforced in conjunction with such code. (Ord. 18745, Eff. 08/11/09)

### **6.402 Scenic Preservation Areas and Corridors**

#### **A. Scenic Preservation Areas Established**

The following scenic preservation areas are hereby established based on their scenic, cultural, architectural or historic character. Generalized maps of these areas appear in appendix B. For official maps of the districts, please contact the Planning and Development Department. (See Sections 2.102 and 6.413B)

1. Fort Worth Stockyards National Register Historic District
2. Central Business District Scenic Preservation Area
3. Cultural District Scenic Preservation Area
4. Medical District Scenic Preservation Area
5. Fairmount/Southside Historic District
6. Elizabeth Boulevard National Register Historic District
7. Circle Park Conservation District
8. Grand Avenue National Register Historic District
9. Masonic Widows Orphans Home Historic District
10. Kenwood Court Historic District

#### **B. Scenic Preservation Area Boundaries.** All scenic preservation area boundary lines shall be measured to the centerlines of all public or railroad rights-of-way bordering the areas.

#### **C. Scenic Preservation Corridors Established.** In addition to the areas established above, the following scenic preservation corridors are designated based on their scenic, cultural, architectural or historic character. (See Chapters 3, Article 5 and section 6.413.B)

1. *Arterial scenic corridors.* Arterial scenic corridors shall be measured 200 feet from each side of the public right-of-way of the following roadways.
  - a. North Main Street from the Historic Stockyards to Downtown.
  - b. Lancaster Avenue from Camp Bowie Boulevard to South Beach Street.
  - c. University Drive/North Side Drive/Oakhurst Scenic Drive from Granbury Road to Belknap Street.
  - d. Camp Bowie Boulevard from University Drive to I-30 (West Freeway).
  - e. Hemphill Street from Allen Avenue south to Felix Street.
  - f. Jacksboro Highway from Lake Worth (100 year floodplain, 600 feet elevation above sea level) to the southerly end of Nine Mile Bridge Road and from 500 feet north of the Municipal Golf Course to North Side Drive.
  - g. Randol Mill Road/1st Street from Haltom Road east to Bridgewood Drive and from .25 miles east of Loop 820 East to John T. White Road.
  - h. East Berry Street from Mitchell Boulevard to Old Mansfield Highway.
  - i. South Hulen Street from Vickery Boulevard south to Loop 820 South.
  - j. Bryant Irvin Road from Vickery Boulevard south to Oakmont Boulevard.
  - k. Angle Avenue/Marine Creek Parkway from Loop 820 West (Jim Wright Freeway) to Northwest 28th Street.
  - l. Evans Avenue from Terrell Avenue to East Berry Street.
  - m. Horne Street from I-30 to Vickery Boulevard.
  - n. Amanda Avenue from Ramey Street to East Rosedale Street.
  - o. South Riverside Drive from I-30 (East Freeway) to Wichita Street.
  - p. 4th Street from Downtown to South Riverside Drive.
  - q. East and West Rosedale from University Drive to Loop 820 East.
  - r. Seminary Drive from I-35W (South Freeway) to Wichita Street.
  - s. Vickery Boulevard from I-35W (South Freeway) to South Ayers Avenue.
  - t. White Settlement Road from University Drive to the city limits of Westworth Village.
  - u. Trinity Railway Express corridor from the east Fort Worth city limit line west to Downtown.
2. *Freeway scenic corridors.* Freeway scenic preservation corridors shall be measured 660 feet from each side of the public right-of-way of the following roadways:
  - a. I-35W (North Freeway) from 28th Street exit south to the centerline of the Trinity River.
  - b. I-30 (East Freeway) from Downtown east to Loop 820 East.
  - c. U.S. Hwy. 287 (Martin Luther King Freeway) from Downtown southeast to Village Creek Road.
  - d. Loop 820 West (Jim Wright Freeway) from .25 miles north to .25 miles south of Lake Worth (100 year floodplain, 600 feet elevation above sea level).
  - e. Loop 820 East from .25 miles north of the first bridge abutment north of Mosier Lake to the southerly boundary of the 100 year floodplain of the West Fork of the Trinity River (approximately 150 feet).
  - f. S. H. 121 (Chisholm Trail Parkway) from I-30 downtown to the southerly boundary of the city limits. (Ord. No. 21271, Eff. 07/01/14)
3. *Future scenic corridors.*
  - a. It is the intent of this section that in the event Jacksboro Highway (U.S. Hwy. 199) is widened, the width of the scenic preservation corridor along Jacksboro Highway shall be increased to 660 feet wide from each side of the final alignment of the public right-of-way, after notice and hearing in accordance with Section 2.102. (Ord. No 21271, Eff. 07/01/14)

**D. Scenic Preservation Corridor Boundaries.** When a corridor designated under this section ends at an intersection with a right-of-way that is not designated as part of a corridor, the corridor shall terminate at the centerline of the non-designated right-of-way.

### 6.403 Signs Not Requiring a Permit

The following signs are exempted from the requirements of this Article and may be erected or constructed without a permit:

1. Signs on vehicles or trailers, provided, however, signs on vehicles or trailers that are parked or located for the primary purpose of displaying the sign are prohibited pursuant to Section 6.405 below.
  2. Temporary signs, as follows:
    - a. Temporary decorative flags.
    - b. Temporary signs erected in accordance with temporary banner policy administered by the Transportation and Public Works Department for signs in the public right-of-way, large banner policy administered by the Parks and Community Services Department for signs on park property, policy governing erection of banners on Main Street, and other temporary banner policies administered by City Departments or their designees.
    - c. One temporary sign is permitted per business during its business hours subject to the following conditions:
      - i. the sign shall be displayed on private property within ten (10) feet of the front door of the business or tenant space;
      - ii. the sign shall not exceed 8 square feet;
      - iii. the sign shall not exceed forty-two (42) inches in height;
      - iv. the sign shall be constructed of rigid weather resistant materials and be kept in good condition;
      - v. the sign shall not be illuminated;
      - vi. the sign shall not contain any moving elements;
      - vii. the sign may not be located in the Public Open Space Easement (POSE);
      - viii. the sign shall not impede, obstruct or interfere with the flow of pedestrian traffic on a sidewalk or access to entrance of a business.
- Provided however, a temporary sign may be displayed in the public right-of-way without the necessity of obtaining City Council approval under the following conditions:
- i. there is no adequate space on the private property to place the sign; and
  - ii. the front door of the business is less than ten (10) feet from the sidewalk edge or the curb, whichever is the closest to the business; and
  - iii. the sign meets all of the criteria listed in ii through viii above.
3. Warning, security and directional signs for parking or vehicle access.
  4. Government signs, flags, insignia, legal notices or informational, directional or traffic signs.
  5. Political signs referring to the candidates or issues involved in a public election, subject to the following conditions:
    - a. The sign is located on private real property with the consent of the property owner;
    - b. The sign does not exceed eight feet in height;
    - c. The sign may not have an effective area greater than 36 square feet;
    - d. The sign shall not be illuminated;
    - e. The sign shall not contain any moving elements.
  6. Signs in windows subject to the following:
    - a. Window signs may occupy a maximum of 25% of the window area on each building façade. However, signs exceeding 10% of the window area shall be included in the calculation of the maximum square footage of on-premise signage allowed as described in Section 6.408F.
    - b. Window signs shall be limited to the first floor of a multi-story building.
    - c. Window area shall be calculated as described in Section 6.406C.
  7. Other than electrical, all signs not visible from off the property.
  8. Nameplate and street address signs not exceeding one square foot in area.

9. One non-illuminated real estate sign, temporary in nature, advertising the sale or lease of real property on which the sign is located or announcing contemplated improvements of real property on which the sign is located; provided, however, that said sign shall not exceed eight square feet in area in any one- or two-family dwelling district or 60 square feet in area and eight feet in height in any other district; provided, further, however, on corner lots and through lots, one such sign, shall be allowed for each street on which the lot has frontage. The sign shall be removed within 30 days after the sale or occupancy of the property.
10. One non-illuminated estate or garage sale sign, not to exceed two square feet in area, temporary in nature, advertising the sale of items on property for which a garage sale permit has been obtained. The sign shall be removed within 24 hours after the sale ends.
11. One construction sign, not exceeding four square feet in area in any one- or two-family dwelling district or 40 square feet in area and 12 feet in height in any other district, denoting the owner, architect, financial institution, general contractor, subcontractor or any statement pertaining to the project on the real property on which the sign is located; provided, however, on corner lots and through lots, one such sign shall be allowed for each street on which the lot has frontage. The sign shall be removed within 30 days after completion of the project.
12. "No Dumping," "No Trespassing," and "No Solicitation" signs.
13. Noncommercial residential signs. In addition to the other noncommercial signs permitted by this article, a maximum of four signs not exceeding a total of 16 square feet in area may be erected on any lot used for residential purposes and may contain noncommercial copy. No one sign shall exceed eight square feet in area.
14. Signs depicting or relating to a national, local or religious holiday or season if installed maintained or displayed for not more than 45 consecutive days.
15. Signs designed and used in conjunction with aircraft.
16. Signs of not more than two (2) square feet with a ground clearance of not more than four (4) feet within twenty (20) feet of a driveway or other ingress/egress to private property which restricts parking on said property. Corners of this type of sign shall be mitered or rounded corner signs.
17. Signs erected by a public utility or transportation organization operating pursuant to a franchise agreement with the City, where such signs are erected or displayed for the purpose of public instruction, traffic control and similar uses incidental to the public interest.  
(Ord. No. 13286, Eff. 02/02/98; 19227, Eff. 7/20/10)

#### 6.404 Temporary On-Premise Signs Requiring a Permit

- A. All temporary signs not previously exempted under Section 6.403, including inflatable or balloon signs, portable signs on trailers and banners, shall require a permit. Temporary signs are permitted only in the "CF" Community Facilities and "ER" Neighborhood Commercial Restricted or less restrictive districts. Temporary signs must meet all requirements of the sign code (Chapter 29 of the City Code), including permitting requirements.
  1. Signs with the exception of inflatable or balloon signs, shall be a maximum size of 60 square feet.
  2. Only one such sign shall be allowed per business, not to exceed two signs per platted lot. On lots with more than 300 feet of street frontage, one sign shall be allowed per business, not to exceed three signs.
  3. No temporary signs shall be located within 100 feet of another temporary sign.
  4. One temporary portable sign or banner shall be permitted for a period of 30 consecutive days, provided only one sign or banner shall be permitted during the 30 day period and there must be at least 30 days between the display of each sign or banner.
  5. Inflatable or balloon signs shall be allowed. Only 60 square feet of Advertised Message Area shall be allowed on an inflatable or balloon regardless of the size of the inflatable or

balloon. Only one inflatable or balloon sign shall be permitted for a period of 30 consecutive days, provided only one inflatable or balloon sign shall be permitted during the 30 day period and there must be at least 30 days between the display of each inflatable or balloon sign. (Ord. 18745, Eff. 08/11/09)

- B. For new residential development, temporary subdivision signs shall be permissible, for the marketing of the residential subdivision, subject to the following provisions:
1. Signs shall be a maximum size of 64 square feet with no more than two support posts.
  2. Signs shall be no taller than 20 feet.
  3. Only one sign shall be located at an entrance to the subdivision, with a maximum of two signs allowed per residential subdivision. (Ord. No. 18078, Eff. 05/17/08)

### 6.405 Prohibited Signs

The following signs are expressly prohibited within the City of Fort Worth:

1. Off-premise signs, unless provisions for such signs are contained within these regulations.
2. Signs erected in violation of City Building, Electrical or Sign Codes, or other applicable local regulations.
3. Signs erected in violation of federal or state law.
4. Pole signs.
5. Portable signs, except those allowed under Sections 6.403 and 6.404.
6. Animated signs, flashing signs, running message, twinkle or running light signs, and revolving signs or any other sign that moves. Electronic changeable copy signs may be permitted by special exception from the Board of Adjustment in accordance with Section 6.411 below.
7. Signs illuminated to such intensity or brilliance as to cause glare or impair vision. Lighting shall be shielded upward to prevent beams or rays from being directed at any portion of a traveled roadway or an occupied residential area. Nothing herein shall be construed to permit the lighting of signs near airports which would conflict with any regulations adopted by the Federal Aviation Administration in the furtherance of air safety. This requirement shall not apply to internally lit signs with a lighting intensity of less than 150 foot lamberts.
8. Signs erected in or projecting into the public right-of-way unless an encroachment agreement is executed in accordance with the requirements of the Sign Code (Chapter 29 of the City Code) and any other ordinances regulating encroachments.
9. Signs on vehicles or trailers that are parked or located for the primary purpose of displaying the sign. It shall be prima facie evidence that the primary purpose of a vehicle or trailer is to display a sign if the vehicle or trailer is parked on a site for a continuous period exceeding 72 hours.
10. "V" type signs with a face that protrudes from the opposite face at an interior angle greater than 25 degrees. This restriction shall not be construed to prevent oval, cylindrical or box type signs.
11. Signs with sign structure larger than is reasonably necessary to support the sign. (Ord. No. 19227, Eff. 7/20/10)

### 6.406 Measurement of Signs

#### A. Measurement of Detached Signs

The sign area for a detached on-premise sign shall be the area included within vertical and horizontal line projections of the furthestmost points of any logos, letters, or other symbols, composed of the total area of the message, and any border, trim or surface upon which the message is displayed. One sign area will be calculated for a detached sign no matter how the message is displayed. The sign structure shall not be included in the sign area unless there is a sign displayed thereon.

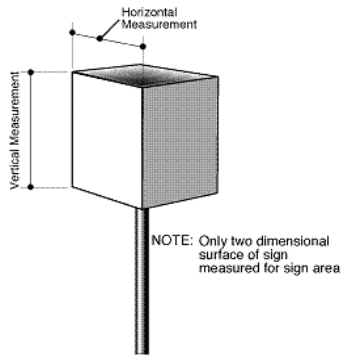

Box Sign

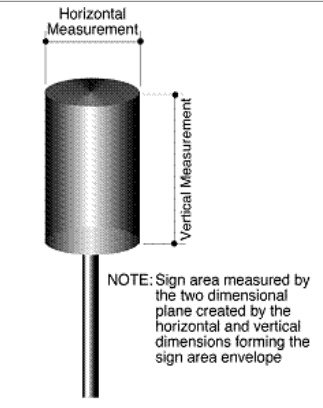

Cylinder Sign

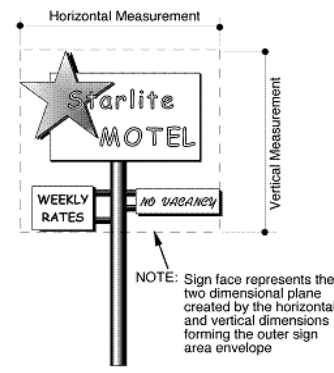

Multi-Panel Flat Sign

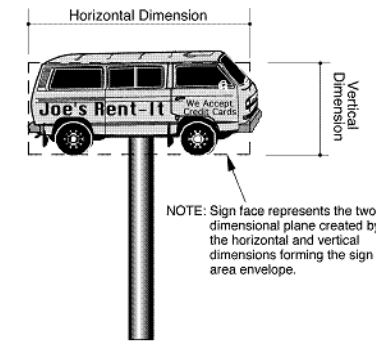

Multi-Surface Sign

**B. Measurement of Attached Signs**

The sign area for an attached on-premise sign shall be the area included within the vertical and horizontal line projection of any logos, letters or other symbols intended to be read together, composed of the total area of the message and any border, trim or surface upon which the message is displayed. There may be several sign areas on the wall of a building depending upon how a sign is displayed.

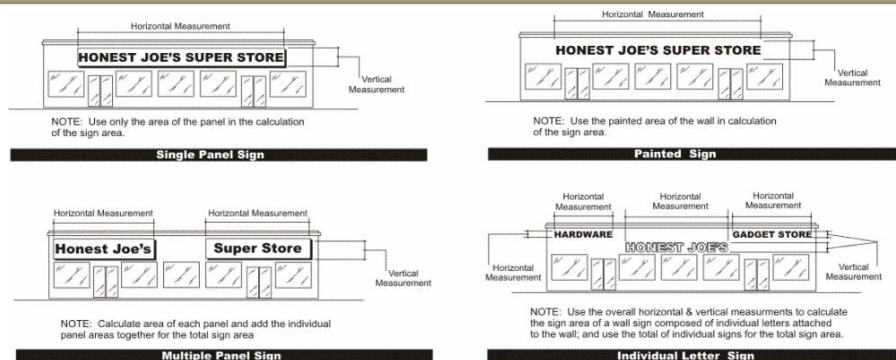
**C. Measurement of Window Area for Window Signs**

The window area for window signs shall be calculated by:

1. Multiplying the window width times the height of the window, with a maximum calculated height of 15 feet; and
2. Determining the area of all glazed openings within a building's exterior wall including the mullions but excluding building cladding. Curved or angled facades may be split or combined with the adjacent façade. (Ord. No. 19227, Eff. 7/20/10)

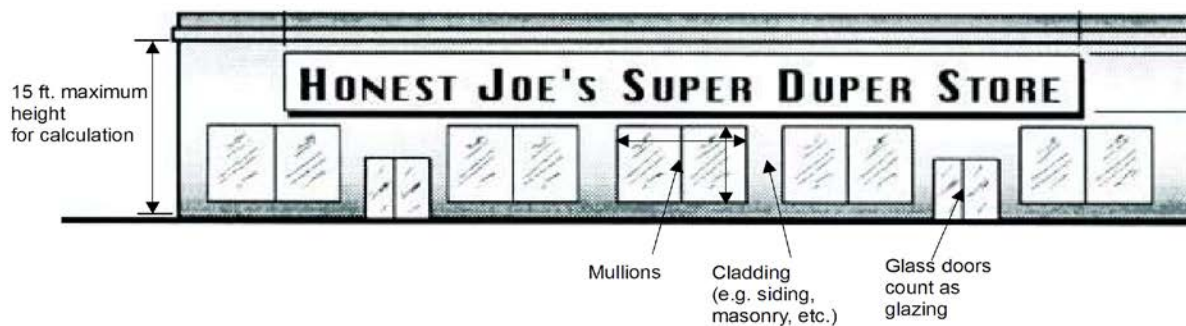
**6.407 Relation to Zoning Districts**

- Signs in "AG," "CF," "MH" and residential districts.** On-premises signs in agricultural, community facilities, manufactured housing, and residential districts are governed by the district regulations set out in the respective district regulations in Chapter 4.
- Signs in Commercial and Industrial Districts.** Signs located in commercial and industrial districts shall conform to the regulations in Sections 6.408 and 6.409.
- Signs in Planned Development Districts.** Signs located in planned development districts shall conform to the regulations in Section 4.300.
- Signs in Conservation Overlay Districts.** Regulations for signs located within conservation districts shall be in accordance with Section 4.400. However, unless indicated otherwise the most restrictive sign regulations shall be followed.

- E. Signs in Urban Design Districts.** Signs located within the boundaries of an Urban Design District shall be generally exempt from the regulations of this Article and shall be in accordance with the pertinent district standards of the Zoning Ordinance. However, the most restrictive sign regulations contained in this Article shall apply unless otherwise indicated in the pertinent district standards. No off-premise signs shall be allowed.
- F. Signs in Special Purpose Districts.**
- 1. Agricultural Districts.** On-Premise signs are permitted as follows:
    - a. An illuminated nameplate bearing the family name of the occupants residing in the residence not to exceed one square foot in area.
    - b. A non-illuminated sign for those uses that are not residential. The sign shall not exceed 30 square feet in area, shall be no higher than 25 feet above grade, and shall be placed a minimum of 10 feet behind the property line. Such sign shall not be placed within 20 feet of drives providing ingress and egress to the property.
  - 2. Community Facilities.** Identification signs shall be permitted subject to the following provisions:
    - a. Signs shall be permitted to identify the use or uses of the property on which displayed.
    - b. a sign or combination of signs shall have a maximum allowable area of exposure along each dedicated street frontage of not more than one square foot of sign area for each 10 linear feet of frontage along said street; provided, however, a minimum of at least one sign shall be allowed having an area of 12 square feet.
    - c. Not more than 50 percent of the total allowable sign area may be located in the required yard space along a dedicated street. However, no individual sign in such required space shall exceed 20 square feet in sign area.
    - d. Symbols which are designed as an integral part of the building structure and symbols which are not visible or readable from the public street shall not be limited by the above regulations.
    - e. Signs located across the street from a one-family or two-family district shall not be illuminated. The source of light for illuminated signs shall not be visible and shall not be intermittent or flashing. Revolving signs shall not be permitted.
  - 3. Manufactured Housing.** An identifying sign shall be permitted at each major entrance to the manufactured home park except that no more than three signs shall be permitted for one park, and such shall be subject to the following provisions:
    - a. Each sign shall contain only the identifying name of the park and its street address.
    - b. Signs may be illuminated but the source of light shall not be visible and shall not be intermittent or flashing; revolving signs shall not be permitted. Signs shall not be lighted between the hours of 10:00 p.m. and 6:00 a.m.
    - c. Such signs may be freestanding but shall have not more than two supports and the top of each sign shall be no more than 8 feet above the grade.

### 6.408 Regulations Governing On-Premise Attached Signs in Commercial and Industrial Districts

Unless exempted under the provisions of Section 6.403, the following regulations shall apply to all attached on-premise signs erected in districts "E" through "K," except for signs for large retail stores which are subject to Section 5.134A.7.

- A. The following size limits apply to buildings occupied by a single tenant and to individual tenant spaces in buildings with multiple tenants. One or more attached signs may be erected on each facade of the occupied space. The signs may have a total area of 10% of the area of the facade to which the signs are attached, with a maximum aggregate area of 500 square feet per facade. Doors and windows shall be included in the calculation of the facade area. The facade area shall be calculated by multiplying the width times the height, with a maximum calculated height of 15 feet. For structures exceeding 15 feet in height, allowable sign square footage shall be calculated as 1.5 square feet per linear foot of building facade.



- B. Length of an attached sign is limited to 75% of the lineal footage of the building or commercial space, whichever is less.
- C. The entire length and height of backlit awnings in which the lighting causes the illumination of the awning, of which the length will be limited to subsection B above, will be counted toward the allowed square footage of attached signs.
- D. Signs shall not project more than three (3) feet from the building or canopy. No sign projection shall encroach over public property except as permitted by the Sign Code (Chapter 29 of the City Code).
- E. Signs may be installed upon the roof subject to the following conditions:
  - 1. The area of the sign shall not exceed 10 percent of the area of the closest wall of the building above which the sign is placed.
  - 2. The sign shall not exceed four feet above the roof or top of the parapet wall at the roof, whichever is higher.
  - 3. All roof signs placed upon a building or buildings upon one platted lot shall be similar in size, shape, area, and design.
- F. A maximum of 1,340 square feet of attached on-premise signage shall be allowed, regardless of the number of facades or buildings associated with a single business or tenant.

### **6.409 Regulations Governing On-Premise Detached Signs in Commercial and Industrial Districts**

Unless exempted under the provisions of Section 6.403, the following regulations shall apply to all detached on-premise signs erected in districts "E" through "K", except for signs for large retail stores subject to Section 5.134A.8 and for signs in mixed-use districts which are additionally subject to Section 4.1300D.3, Section 4.1301D.3, Section 4.1302D.3, and Section 4.1303D.3.

#### **A. Types of Detached Signs**

- 1. Monument signs are permitted by right.
- 2. Pylon signs are only permitted as part of a unified sign agreement, per Section 6.410.
- 3. Freeway signs are only permitted on property immediately adjacent to a designated freeway.

#### **B. Monument Signs**

- 1. Maximum height: 8 feet
- 2. Maximum width: 16 feet
- 3. Maximum advertised message area: 96 square feet
- 4. Minimum ground contact: 75% of structure's width

#### **C. Pylon Signs**

- 1. Maximum height: 8 feet at the right-of-way line and one additional foot in height for each one foot of setback, up to 25 feet. Set back sign one foot for each foot in height from all adjacent property lines.
- 2. Maximum width: 16 feet
- 3. Maximum advertised message area: 300 square feet
- 4. Minimum ground contact: 50% of structure's width

#### **D. Freeway Signs**

- 1. Maximum height: 25 feet allowed at the right-of-way line and one additional foot in height for each one foot of setback, up to 35 feet. Set back sign one foot for each foot in height from all adjacent property lines. (Administrative approval allowed for up to 50 feet in height to allow sign to be 20 feet above adjacent main travel lanes of freeway.)
- 2. Maximum width: 24 feet
- 3. Maximum advertised message area: 320 square feet
- 4. Minimum ground contact: 25% of structure's width

- E. **One detached sign may be erected on each platted lot or on property which is subject to a unified sign agreement executed in accordance with 6.410. Additional signs may be erected under the following circumstances:**

1. On corner lots and through lots and on corner tracts and through tracts that are subject to a unified sign agreement, one sign shall be allowed on each street on which the property has frontage;
  2. On lots having more than 100 feet of street frontage, more than one detached sign may be installed provided that such signs are at least 100 feet apart and the total area of all signs does not exceed the maximum allowable sign area set forth in paragraph F below; and
  3. On property subject to a unified sign agreement having more than 300 feet of street frontage, more than one detached sign may be installed provided that such signs are at least 300 feet apart and the total area of all signs does not exceed the maximum allowable sign area set forth in paragraph B below.
- F. The maximum allowable sign area shall be the lesser of one square foot of signage per linear foot of street frontage, or:**
1. 120 square feet for minor arterials or neighborhood streets;
  2. 165 square feet for major arterials;
  3. 195 feet for principal arterials;
  4. 600 square feet from freeways or toll roads.
- Street types are as defined in the most recently adopted/amended Master Thoroughfare Plan.
- G. A minimum of 25% of the sign face, excluding the base, shall contain non-advertised message area (see definition). The non-advertised message area shall be of construction materials similar to the building and shall be non-illuminated.**

#### 6.410 Unified Sign Agreements for On-Premise Signs

The City Council or Planning and Development Director may authorize the consideration of a single premise of two or more adjacent lots or two or more lots that are separated only by right-of-way for the purpose of erecting on-premise signs, if a unified sign agreement approved and executed in accordance with this section.

- A. Lots Eligible for Unified Sign Agreement.**
- b. Two or more adjacent lots. In order to be considered to be adjacent, lots must be immediately adjacent to each other and not at cross corners or connected by narrow strips of land too small to serve as emergency access easements. Lots separated by right-of-way must be directly across the right-of-way and, except for the right-of-way, must be adjacent and not at cross corners or connected by narrow strips of land too small to serve as emergency access easements.
  - c. Single lot. A single platted lot commercial development which contains multiple tenants.
- B. Criteria for Approval.** In deciding whether to approve a single lot commercial development or multiple lots as a single premise for a unified sign agreement, the following criteria shall be considered:
1. All areas to be combined in the unified sign agreement must be part of a clearly defined unified commercial or industrial development constructed as a single destination point for customers and visitors. Attributes of a unified commercial or industrial development include:
    - a. Common name identification to the public;
    - b. Shared parking provided throughout the development;
    - c. Sign structures utilized for shared signage, including identification of the common name of the development;
    - d. Physical layout of the development results in a cohesive development; and
    - e. The area should not be the combination of disparate premises joined solely for the purpose of initiating a unified sign agreement.
  2. The signage proposed pursuant to a unified sign agreement must demonstrate an overall reduction in sign clutter as evidenced by a reduction of 50% in the number of signs that would be allowed in the absence of a unified sign agreement.
  3. No more than 50% of the advertised message area may be used by one tenant.

4. A unified sign agreement shall be authorized only in an "E" or more intensive zoning district.
5. Property can be subject to only one unified sign agreement.

**C. Allowed Signage.**

1. Upon approval of a unified sign agreement, all existing signs shall be removed or brought into compliance with this subsection. All new signs constructed pursuant to the agreement and all existing signs remaining on the property shall comply with this subsection. Existing signs shall not be considered to be nonconforming as a result of erection of signs in accordance with the agreement.
2. Within the area of the unified sign agreement, spacing between detached signs shall be a minimum of 300 feet.
3. The allowed size and height of signs shall be calculated as provided for in Section 6.407 above, except that the length and width of any right-of-way separating lots within the area shall not be counted toward allowable sign square footage.
4. For street frontages greater than 1,000 linear feet, the maximum allowable sign area shall be calculated as one square foot of signage per linear foot of street frontage.
5. Entry features of construction materials similar to the building and other detached signs shall be allowed for commercial or industrial developments over five (5) acres provided that:
  - a. The entry signs must be located on a major arterial or street of higher classification;
  - b. The entry signs are attached to a wall or entry feature;
  - c. Maximum height of the feature is 25 feet;
  - d. Signage is limited to 80 square feet with a maximum height of 10 feet;
  - e. One feature is permitted per frontage; and
  - f. The feature must be located within 50 feet of an entry driveway.

**D. Sign Plan Required.**

1. A sign plan covering the entire area included in the unified sign agreement shall be submitted to the Planning and Development Director for approval. The sign plan shall contain the following information:
  - a. The location, size, and height of all existing and proposed signs;
  - b. Description of development within the area of the unified sign agreement demonstrating the attributes of a unified commercial or industrial development as described in paragraph B.1; and
  - c. Demonstrated compliance with paragraph B.2 showing an overall reduction in sign clutter as evidenced by a reduction of 50% in the number of detached signs.
2. A copy of the sign plan shall be attached to the unified sign agreement and may be amended only with the approval of the Planning and Development Director, upon compliance with the requirements set out in paragraphs C and D above.

**E. Findings.** The Planning and Development Director may administratively approve a unified sign agreement, if on the basis of the sign plan submitted the Director finds that all of the above requirements are met without the necessity of any variances. If the Director finds that variances from the above requirements are necessary for height and size, consideration of the variance(s) shall be by the Board of Adjustment with final approval of the unified sign agreement by the City Council.

**F. Notice of Decision.** Upon review of a unified sign agreement requesting a variance(s) for height, size or location of a unified sign agreement by the Planning and Development Director and after consideration by the Board of Adjustment, notice shall be sent by regular United States Mail to all property owners within 300 feet of the boundaries of the area included in the agreement, as indicated on the most recently approved municipal tax roll. Such notice shall provide a description of the unified sign agreement and the location of the area included in the agreement. The notice shall be mailed no later than 30 days prior to consideration of the unified sign agreement by the City Council.

**G. Execution, Amendment, Termination and Filing of Unified Sign Agreements.**

1. The unified sign agreement shall:

- a. Contain the names and addresses of the owners and the legal descriptions of all properties within the unified sign agreement;
  - b. State that all parties agree that the properties covered by the agreement may be collectively treated as a single premise for the limited purpose of determining the number, size and location of on-premises signs permitted in accordance with this section;
  - c. State that the agreement constitutes a covenant running with the land with respect to all properties subject to the agreement;
  - d. State that all parties agree to defend, indemnify and hold harmless the City of Fort Worth from and against all claims or liabilities arising out of or in connection with the agreement;
  - e. State that the agreement will be governed by the laws of the State of Texas;
  - f. State that the agreement may be amended or terminated only in accordance with paragraph b. below;
  - g. Be approved by the City Council or Planning and Development Director and approved as to form by the City attorney;
  - h. Be signed by all owners of the properties included in the agreement; and
  - i. Be signed by all lien holders, other than taxing entities that have either an interest in the lots covered by the agreement or an improvement on those properties.
2. A unified sign agreement may be amended or terminated as follows:
    - a. The amendment or termination agreement shall be executed by all owners of the properties included in the unified sign agreement, and all lien holders, other than a taxing entity, that have an interest in land covered by the agreement or an improvement on such land.
    - b. A termination agreement shall be approved by the Planning and Development Director if all signs on the property governed by the agreement are in compliance with City sign regulations, as if no unified sign agreement had been executed. Any signs that are not in compliance shall be removed or brought into compliance prior to approval of the agreement by the Planning and Development Director.
    - c. In considering whether to approve an amendment to a unified sign agreement, the Planning and Development Director shall consider the criteria for approval of unified sign agreements set out in paragraph B.
  3. A unified sign agreement or an agreement to amend or terminate such an agreement is not effective until the agreement is approved by the Planning and Development Director and approved as to form by the City attorney, the agreement is filed in the deed records in the county in which the property is located, and two file-marked copies of the agreement are delivered to the Planning and Development Director. (Ord. No. 18995, Eff. 01/23/10)

### 6.411 Electronic Changeable Copy Signs

A. Electronic changeable copy signs may be permitted by special exception of the Board of Adjustment in commercial, industrial, mixed-use, and community facility zoning districts, subject to the following conditions:

1. A maximum of 25% of the sign face may be devoted to changeable copy
2. The message rate shall not change at a rate faster than one message every 20 seconds.
3. Electronic changeable copy signs shall not contain animation, rolling or running letters or message, flashing lights or displays as part of the display.
4. On detached signs, electronic changeable copy shall be limited to monument signs, except where pylon and freeway signs are allowed under Section 6.409.
5. Electronic changeable copy signs shall have automatic dimming technology installed limiting the sign to no more than 0.3 footcandles above ambient light, measured at a distance equaling the square root of the product of the sign's square footage multiplied by 100. The distance shall be rounded to the closest whole number.
6. All sound shall be prohibited.

- B. The Board of Adjustment shall not grant variances which are less restrictive than the conditions of the special exception.
- C. In granting the special exception, the board of adjustment shall consider the following:
1. The presence of other electronic changeable copy signs in the vicinity;
  2. The visibility from residential districts.
  3. The street classification of the adjacent roadways; and
  4. The proximity to scenic areas or corridors.

The Board of Adjustment shall not grant variances which are less restrictive than conditions of the special exception. (Ord. No. 18745, Eff. 08/11/09; 21716, 04/25/15)

### 6.412 Sales Office and Model Home Signs

Sales office and model home signs (signs identifying a developer's sales office/model home sites) are subject to the following:

1. Signs shall not exceed a maximum size of 32 square feet.
2. Signs shall not exceed a maximum height of 6 feet.
3. No sign shall be illuminated between the hours of 10:00 p.m. and 7:00 a.m.
4. Only one sign advertising a model home may be permitted per builder in the subdivision.
5. Sign must be located on the site of the model home/sales office and shall be set back a minimum of ten (10) feet from the public right of way.
6. Model home sign shall be allowed only after a certificate of occupancy has been issued for the model home.
7. No sign may be erected for more than two years.
8. Signs shall meet all requirements of the Sign Code (chapter 29 of the City Code), including permitting requirements.

Box 1

Commentary Box: The maximum size of a model home sign is based on the advertised sign area.

### 6.413 Nonconforming Signs

- A. Permitted Alteration of Nonconforming Signs.** A nonconforming sign may be altered only as follows, subject to complying with permitting requirements set out in the Sign Code (Chapter 29 of the City Code):
1. The sign may be upgraded in accordance with paragraph B below;
  2. Advertising copy, including letters, symbols, or other matter on the sign, may be changed, including the exchange of display faces that are designed to be interchangeable to facilitate the display of advertising copy; provided, however, display faces that are designed to be permanently attached to the supporting sign structure may be replaced only with display faces composed of like materials, e.g., a plywood display face may be replaced only with a plywood display face. Display faces may be replaced only with display faces that are the same size or smaller than the size initially registered as of January 2, 1998, in accordance with Section 29-31 of the sign code, plus cut-out extensions that do not exceed 20 percent of the registered sign area. The temporary use of a sign with a display face that is smaller than the size that was initially registered shall not bar the replacement of the display face with a larger display face, provided that it shall not exceed the size reflected in the initial registration. Notwithstanding anything herein to the contrary, vinyl, paint, or pasted paper may be affixed to a display face composed of any material;
  3. A sign which has been blown down or otherwise destroyed by wind, fire or damages from any other source, may be repaired, provided that the cost of repairing the sign is 60 percent of the cost of erecting a new sign of the same type at the same location, or less. If the cost of repairing the sign is more than 60 percent of the cost of erecting a new sign of the same type at the same location, the sign may not be altered, reconstructed, repaired or replaced, and the owner shall remove the sign or bring it into compliance with

the zoning ordinance, the Sign Code (Chapter 29 of the City Code) and all other applicable ordinances.

4. Maintenance operations may be performed on the sign. For purposes of this section, "maintenance operations" means the process of keeping a sign in good repair. Maintenance operations include: (1) cleaning; (2) painting; (3) repair of parts with like materials in a manner that does not alter the basic design or structure of the sign, provided that the cost of all repairs performed during any consecutive 365-day period is not more than 60 percent of the cost of erecting a new sign of the same type at the same location; and (4) replacement of parts with like materials in a manner that does not alter the basic design or structure of the sign, provided that the cost of all replacement of parts performed during any consecutive 365-day period is not more than 60 percent of the cost of erecting a new sign of the same type at the same location. The 365-day period limitation shall not apply to a sign that has been blown down or otherwise destroyed as described in paragraph 3 above. Examples of actions that are not maintenance operations and are therefore prohibited include, without limitation: (1) converting a sign from a multiple pole structure to a monopole structure; (2) replacing wooden components with metal components; (3) increasing the area or height of a sign, except for increases in area permitted under paragraph 2 above; (4) adding illumination to a non-illuminated sign; (5) adding additional display faces; and (6) converting a sign to utilize animated display or moveable copy technology, including but not limited to signs featuring Tri-Vision technology and (7) updating the technology in an already existing animated display or moveable copy signs. If a sign is dismantled for any purpose other than an alteration or maintenance operation permitted hereunder, the sign may not be altered, reconstructed, repaired or replaced, and the owner shall remove the sign or bring it into compliance with this ordinance, the Sign Code (Chapter 29 of the City Code) and all other applicable ordinances.
5. All other alterations of any nature whatsoever in connection with nonconforming signs are prohibited. If any such alteration is performed, the owner shall remove the sign or bring it into compliance with the comprehensive zoning ordinance, the Sign Code (Chapter 29 of the City Code) and all other applicable ordinances. The cost of any accessory use to a sign, including without limitation a communication antenna and support facilities, shall not be included in calculating the cost of erecting a new sign at the same location pursuant to paragraphs 3 and 4 above.

**B. Upgrading Existing Off-Premises Signs.** In order to encourage the removal of off-premises signs from designated scenic areas and corridors, an owner may upgrade an existing off-premises sign, with City Council approval, under the conditions set out below.

1. Definition of "upgrading." For purposes of this section, "upgrading" means making any change to an existing off-premises sign, other than repairs and maintenance operations permitted pursuant to paragraph A above, provided, however, signs erected on buildings and multiple signs located within 25 feet of each other on the same structure or separate structures shall not be upgraded. Upgrading of off-premises signs shall be permitted only in areas that have not been designated as a scenic area or corridor pursuant to Section 6.402. Upgrading of off-premises signs in designated scenic areas is prohibited.
2. Calculation of credits for removal of off-premises signs.
  - a. Any person wishing to upgrade an off-premises sign must remove four off-premises signs from designated scenic areas or corridors and must have square footage credits, as defined below, equal to the size of the sign to be upgraded. No credit will be given for signs that have not been registered in accordance with Section 29-31 of the Sign Code (Chapter 29 of the City Code).
  - b. The Planning and Development Department shall create an account for each sign owner showing the date of removal and the location and dimensions of the signs removed. The account shall reflect two types of sign credits, as follows:
    - i. One-fourth credit for each off-premises sign that is removed ("structure credit");
    - and

- ii. One-fourth credit for each square foot of display area that is removed, excluding cut-out extensions ("square footage credit"). The number of square footage credits awarded shall be equal to the display area of the sign, and shall not be increased if copy is displayed on more than one side of the sign.
      - c. Any sign credits not used within five years of their creation shall expire.
      - d. A sign owner may transfer sign credits; provided, however, the transfer does not extend the five year term of such credits.
3. Use of sign credits for upgrading off-premises sign. A permit to upgrade an off-premises sign shall be issued only if the applicant has at least one structure credit and sufficient square footage credits. When the permit to upgrade the existing sign is issued, the development department shall deduct from the sign owner's account:
  - a. One (1) structure credit for each sign to be upgraded; and
  - b. Square footage credits equal to the square footage of display area of the sign to be upgraded.

**Example:** One 672 square foot sign (with advertising copy on one side only or on both sides) can be upgraded by using one structure credit and 672 square footage credits. In order to earn one structure credit and 672 square footage credits, it would be necessary to remove four off-premises signs with display areas totaling 2,688 square feet.
4. Procedure for removal of off-premises. Any person wishing to obtain sign credits for removal of an off-premises sign shall submit written notice of intent to remove the sign to the Planning & Development department, before taking any action to remove the sign. The notice shall be submitted on a form provided by the Planning & Development department. No sign credits shall be awarded for any off-premise sign that is removed before the notice of intent is submitted to and accepted by the Planning & Development department, except as set forth below. Eligibility for credit shall be determined as follows:
  - a. Illegal signs. No sign credits will be awarded for removal of illegal off-premises signs.
  - b. Nonconforming signs that have been illegally altered. No sign credits will be awarded for illegally altered nonconforming signs that are required to be removed in accordance with paragraph A.
  - c. Signs removed pursuant to eminent domain. No sign credits will be awarded for removal of signs for which compensation is paid pursuant to eminent domain proceedings.
  - d. Removal of damaged nonconforming signs. No sign credits will be awarded for the removal of a nonconforming sign that is blown down or otherwise destroyed by wind, fire or damages from any other source, where the cost of repairing the sign is more than 60 percent of the cost of erecting a new sign of the same type at the same location. If the damaged nonconforming sign can be repaired at a cost of 60 percent or less of the cost of erecting a new sign, the owner may elect to repair the sign. In the alternative, the owner may remove the sign and receive sign credits for the removal. The owner shall submit a notice of intent to the development department before removing the sign, unless the immediate removal of the damaged sign is required because it presents a safety hazard.
5. No increase in area or height. An off-premises sign with a display area exceeding 672 square feet that is upgraded in accordance with this section shall be reduced to no larger than 672 square feet. The display area of a sign that is 672 square feet or less in size may not be increased as a result of the upgrade. No height increase is allowed for any upgraded sign.
6. Zoning Commission recommendation and City Council approval required. The zoning commission shall conduct a public hearing on the upgrade request and shall submit its recommendation to the city council. No off-premises sign may be upgraded without city council approval after a public hearing. Notice of the zoning commission and city council hearings shall be given in accordance with Section 3.502.
7. No violation of federal or state law. Nothing herein shall permit a nonconforming sign to be upgraded in violation of any federal or state law. (Ord. No. 13657, Eff. 12/05/98)

### 6.414 Kiosk Signs

Kiosk signs provide a uniform, coordinated method of providing homeowners, developers and municipalities a means of utilizing directional signs, while minimizing the negative impacts to the City and its residents. Kiosk signs shall be used for homebuilders, developer and subdivision directional signage. Kiosk signs are also intended to provide service to the public on directions to municipal facilities and parks.

- A. The Planning and Development Director may approve and permit kiosk signs subject to the following requirements and limitations:
  1. All kiosk signs and individual sign panels must have approval by the City. Fees for kiosk signs shall be as set forth in Chapter 25 of the City Code.
  2. Placement and installation of kiosk signs must be in accordance with specifications. A site plan must be submitted to the Planning and Development Department for review and approval. The Department of Transportation and Public Works must approve the location of all kiosk signs prior to installation.
  3. Sign structures shall be located at least 100 feet apart from each other, excluding signs located across a street from each other.
  4. Directional kiosk signs shall not obstruct the use of sidewalks and walkways, and shall not obstruct visibility triangles designated by the City for vehicles, pedestrians or traffic control signs.
  5. In the event a kiosk sign is not constructed within sixty (60) days after the date of issuance of a kiosk sign permit, such permit shall expire.
  6. Kiosk sign structures shall be ladder type with individual sign panels of uniform height and background color. Dimensions shall be as follows:
    - a. 6' x 4'
    - b. 8' x 4'
    - c. 10' x 4'
    - d. 12' x 4'
  7. Kiosk signs may be located on private property, provided written permission is obtained from the property owner. Such kiosk signs shall not exceed the dimensions of 4' x 12' in height.
  8. Kiosk signs shall not be illuminated.
  9. Kiosk signs installations shall include break away design features as required in right of way areas, as depicted in Texas Department of Transportation's Sign Mounting Details for Roadside Signs.
  10. No signs, pennants, flags or other devices for visual attention or other appurtenances shall be placed on the directional kiosk signs.
  11. In the event the contractor/developer is unable to provide a kiosk sign for infill or smaller development tracts, the developer may work with the Planning and Development Director or designee to develop a signage plan for that particular development.
- B. Services Contract: The City Council may, by a duly executed services contract, grant to a qualified person or company the right to design, erect and maintain directional kiosk signs within the City.

### 6.415 Noncommercial Copy

Notwithstanding anything contained herein to the contrary, any sign authorized under this article to contain commercial copy may contain noncommercial copy in lieu of commercial copy.