

SUMMARY OF TRAFFIC SIGNAL ITEMS																
LOCATION	416 6029	416 6032	416 6034	610 6002	610 6102	618 6046	618 6047	618 6053	618 6054	620 6007	620 6008	620 6009	620 6010	624 6010	628 6144	680 6002
	DRILL SHAFT (RDWY ILL POLE) (30 IN)	DRILL SHAFT (TRF SIG POLE) (36 IN)	DRILL SHAFT (TRF SIG POLE) (48 IN)	RELOCATE RD IL ASM (SHOE-BASE)	REPLACE LUMINAIRE W/LED (250W EQ)	CONDT (PVC) (SCH 80) (2")	CONDT (PVC) (SCH 80) (2") (BORE)	CONDT (PVC) (SCH 80) (3")	CONDT (PVC) (SCH 80) (3") (BORE)	ELEC CONDR (NO. 8) BARE	ELEC CONDR (NO. 8) INSULATED	ELEC CONDR (NO. 6) BARE	ELEC CONDR (NO. 6) INSULATED	GROUND BOX TY D (162922) W/ APRON	ELC SRV TY D 120/240 060(NS)SS(E)PS(U)	INSTALL HWY TRF SIG (ISOLATED)
ALTAMESA & McCART SIGNAL	LF 8	LF 26	LF 44	EA 1	EA 2	LF 40	LF 105	LF 380	LF 585	LF 955	LF 1220	LF 15	LF 30	EA 6	EA 1	EA 1
PROJECT TOTALS	8	26	44	1	2	40	105	380	585	955	1,220	15	30	6	1	1

SUMMARY OF TRAFFIC SIGNAL ITEMS															
LOCATION	680 6004	682 6001	682 6002	682 6003	682 6004	682 6005	682 6006	682 6018	682 6054	684 6030	684 6031	684 6033	684 6046	684 6079	
	REMOVING TRAFFIC SIGNALS	VEH SIG SEC (12") LED (GRN)	VEH SIG SEC (12") LED (GRN ARW)	VEH SIG SEC (12") LED (YEL)	VEH SIG SEC (12") LED (YEL ARW)	VEH SIG SEC (12") LED (RED)	VEH SIG SEC (12") LED (RED ARW)	VEH SIG SEC (12") LED (RED ARW)	PED SIG SEC (LED) (COUNTDOWN)	BACKPLATE W/REF BRDR (3 SEC) (VENT) ALUM	TRF SIG CBL (TY A) (14 AWG) (4 CONDR)	TRF SIG CBL (TY A) (14 AWG) (5 CONDR)	TRF SIG CBL (TY A) (14 AWG) (7 CONDR)	TRF SIG CBL (TY A) (14 AWG) (20 CONDR)	TRF SIG CBL (TY C) (12 AWG) (2 CONDR)
ALTAMESA & McCART SIGNAL	EA 1	EA 10	EA 9	EA 12	EA 7	EA 12	EA 7	EA 12	EA 17	LF 120	LF 880	LF 2260	LF 850	LF 2735	
PROJECT TOTALS	1	10	9	12	7	12	7	12	17	120	880	2,260	850	2,735	

SUMMARY OF TRAFFIC SIGNAL ITEMS													
LOCATION	686 6039	686 6043	686 6065	686 6067	687 6001	688 6001	688 6003	6010 6011	6058 6001	6292 6001	6396 6001	6421 6001	
	INS TRF SIG PL AM(S)1 ARM(36') LUM	INS TRF SIG PL AM(S)1 ARM(40') LUM	INS TRF SIG PL AM(S)1 ARM(65')	INS TRF SIG PL AM(S)1 ARM(65') LUM	PED POLE ASSEMBLY	PED DETECT PUSH BUTTON (APS)	PED DETECTOR CONTROLLER UNIT	CCTV FIELD EQUIP (DIGITAL) (INSTL ONLY)	BBU SYSTEM (EXTERNAL BATT CABINET)	RVDS (PRESENCE DETECTION ONLY)	COFW EV PREEMPT (INSTALLATION ONLY)	COFW CELLAR ROUTER (INSTALLATION ONLY)	
ALTAMESA & McCART SIGNAL	EA 1	EA 1	EA 1	EA 1	EA 10	EA 12	EA 1	EA 1	EA 1	EA 6	EA 4	EA 1	
PROJECT TOTALS	1	1	1	1	10	12	1	1	1	6	4	1	

---NOT FOR CONSTRUCTION---

THIS DOCUMENT HAS BEEN RELEASED FOR THE PURPOSE OF INTERIM REVIEW UNDER THE AUTHORITY OF ZEGEYE Z. KEBEDE, P.E. 121726 IT IS NOT TO BE USED FOR CONSTRUCTION PURPOSES. 05/05/2021

---NOT FOR CONSTRUCTION---

5/5/2021 1:09:25 PM c:\projectwise\zkebede@lan-inc.com\d0775534\Quantity Summary.dgn



Lockwood, Andrews & Newnam, Inc.
A LEAO A DALY COMPANY

TBPE Firm No.2614
1320 S. UNIVERSITY DRIVE,
UNIVERSITY CENTER II, SUITE 450
FORT WORTH, TEXAS 76107
(817) 820-0420



SIGNAL QUANTITY SUMMARY

REVISIONS	FED. RD. DIV. NO. 6	STATE AID PROJECT NO. SEE TITLE SHEET		SHEET NO. 91
	STATE	DISTRICT	COUNTY	91
	TEXAS	FTW	TARRANT	
	CONTROL	SECTION	JOB	HIGHWAY NO.
	0902 0902	90 90	119 192	McCART

5/5/2021 1:09:36 PM
 c:\projects\wise\zkebede\lan-inc.com\d0775534\McCart Signal Layout.dgn

PROPOSED SIGNAL HEADS

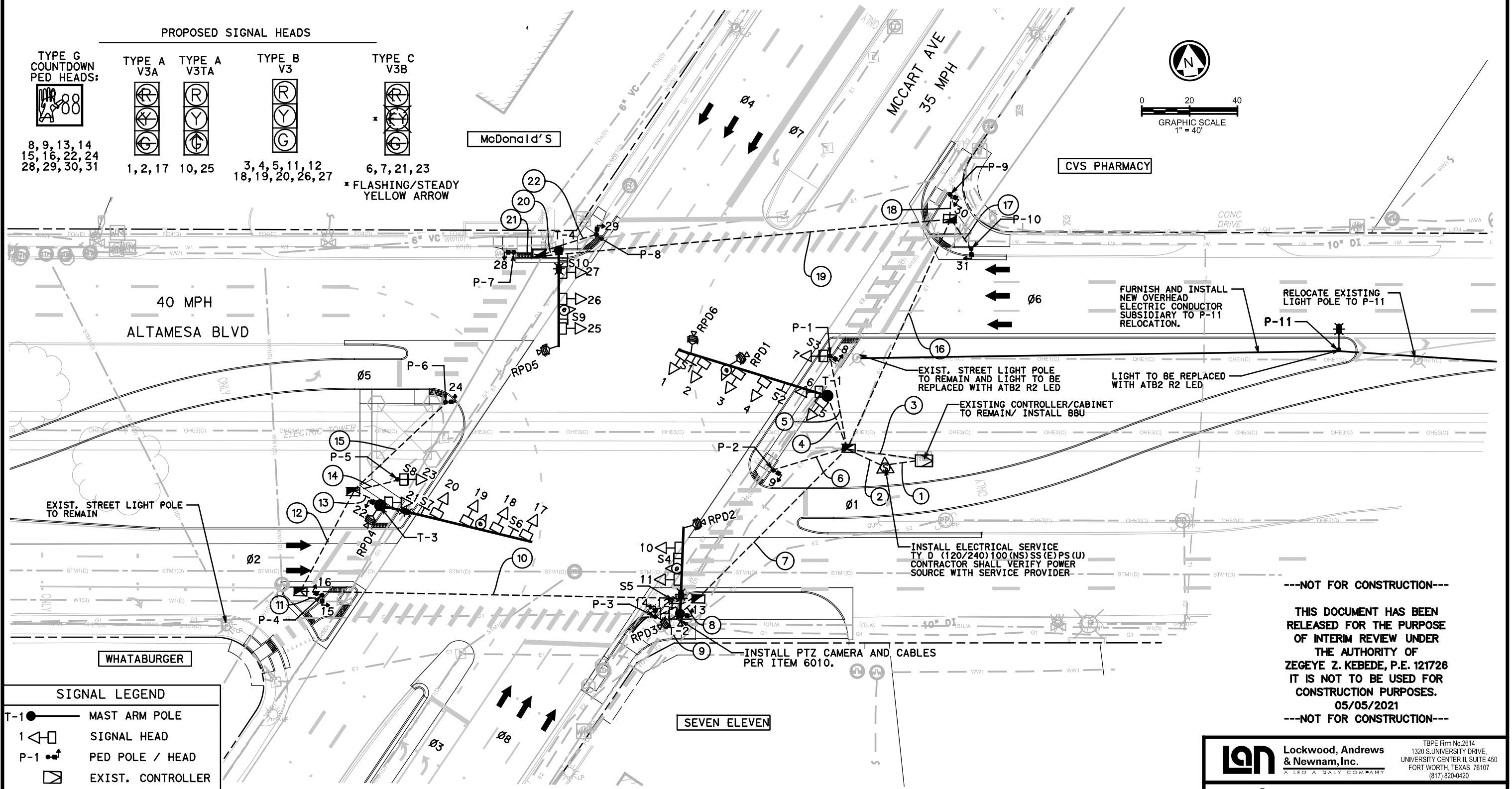
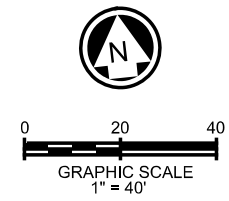
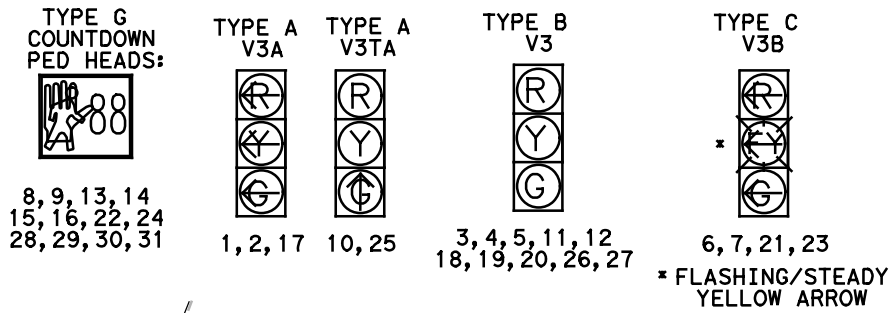

---NOT FOR CONSTRUCTION---

THIS DOCUMENT HAS BEEN RELEASED FOR THE PURPOSE OF INTERIM REVIEW UNDER THE AUTHORITY OF ZEGEYE Z. KEBEDE, P.E. 121726. IT IS NOT TO BE USED FOR CONSTRUCTION PURPOSES. 05/05/2021

---NOT FOR CONSTRUCTION---

SIGNAL LEGEND

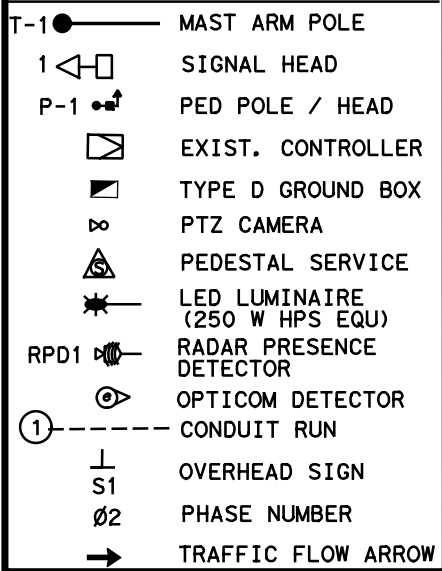

PROPOSED SIGNS

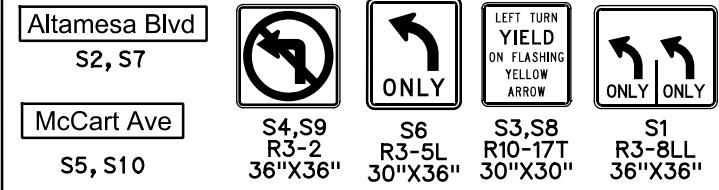

NOTES TO CONTRACTOR:

- ALL HEIGHTS AND LOCATIONS OF ALL SIGNAL RELATED ITEMS, PAVEMENT MARKINGS, SIGNING, ETC. ARE DIAGRAMMATIC ONLY AND MAY BE ADJUSTED IN THE FIELD TO ACCOMMODATE FIELD CONDITIONS AND TO ACHIEVE THE BEST POSSIBLE CONFIGURATION AS DIRECTED BY THE TRAFFIC ENGINEER.
- CONTRACTOR SHALL FIELD VERIFY ALL EXISTING UNDERGROUND AND AERIAL UTILITIES PRIOR TO THE INSTALLATION OF MAST ARM POLES, MAST ARMS, AND LUMINAIRE ARMS.
- CITY WILL FURNISH OPTICOM DETECTORS, PTZ CAMERA, 4G MODEM, COMMUNICATION GEAR.
- CONDUCTORS FOR APS SHALL RUN DIRECTLY FROM CONTROLLER TO PUSHBUTTONS BYPASSING TERMINAL BLOCKS.
- CONDUIT RUN TO POWER SOURCE IS SUBSIDIARY TO ELECTRICAL SERVICE INSTALLATION. EXACT LOCATION OF THE POWER SOURCE TO BE VERIFIED WITH SERVICE PROVIDER.
- REFER TO EXISTING UTILITIES AND REMOVAL PLANS FOR EXISTING CONDITION INFORMATION.

©2021 by Texas Department of Transportation; all rights reserved

LAN Lockwood, Andrews & Newnam, Inc. A LEAO A DALY COMPANY

TBPE Firm No. 2614
 1320 S. UNIVERSITY DRIVE,
 UNIVERSITY CENTER II, SUITE 450
 FORT WORTH, TEXAS 76107
 (817) 820-0420

Texas Department of Transportation

TRAFFIC SIGNAL LAYOUT

REVISIONS	FED. RD. DIV. NO.	STATE AID PROJECT NO.		SHEET NO.
	6	SEE TITLE SHEET		92
	STATE	DISTRICT	COUNTY	
	TEXAS	FTW	TARRANT	
CONTROL	SECTION	JOB	HIGHWAY NO.	
0902	90	119	McCART	
0902	90	192		

5/5/2021 1:09:52 PM
 c:\projectwise\zkebede@lan-inc.com\d0775534\McCart Signal Corner Details 1.dgn

NORTHWEST CORNER

NORTHEAST CORNER

SIGNAL LEGEND	
T-1	MAST ARM POLE
1	SIGNAL HEAD
P-1	PED POLE / HEAD
	EXIST. CONTROLLER
	TYPE D GROUND BOX
	PTZ CAMERA
	PEDESTAL SERVICE
	LED LUMINAIRE (250 W HPS EQU)
RPD1	RADAR PRESENCE DETECTOR
	OPTICOM DETECTOR
①	CONDUIT RUN
	OVERHEAD SIGN
Ø2	PHASE NUMBER
	TRAFFIC FLOW ARROW

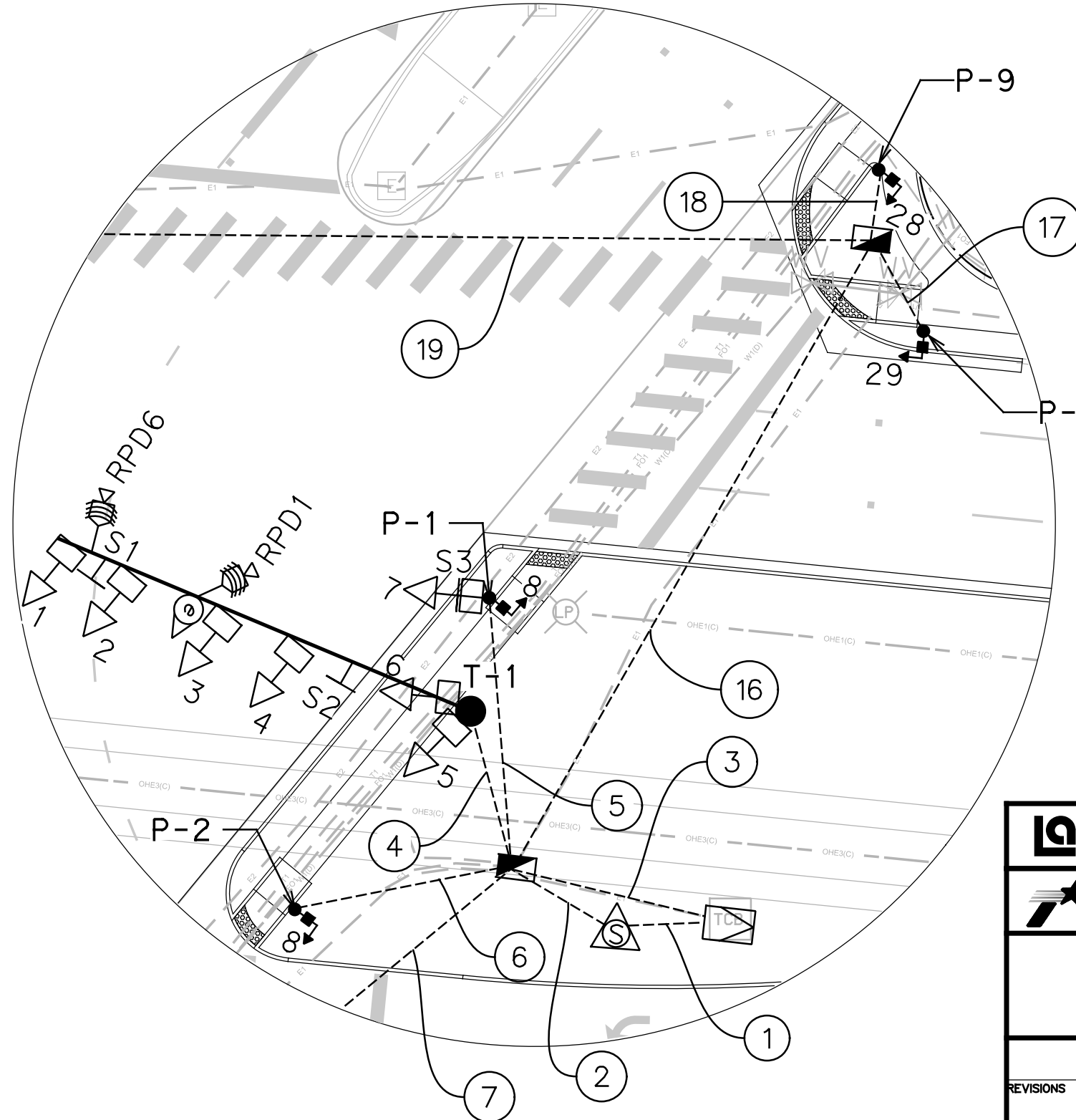
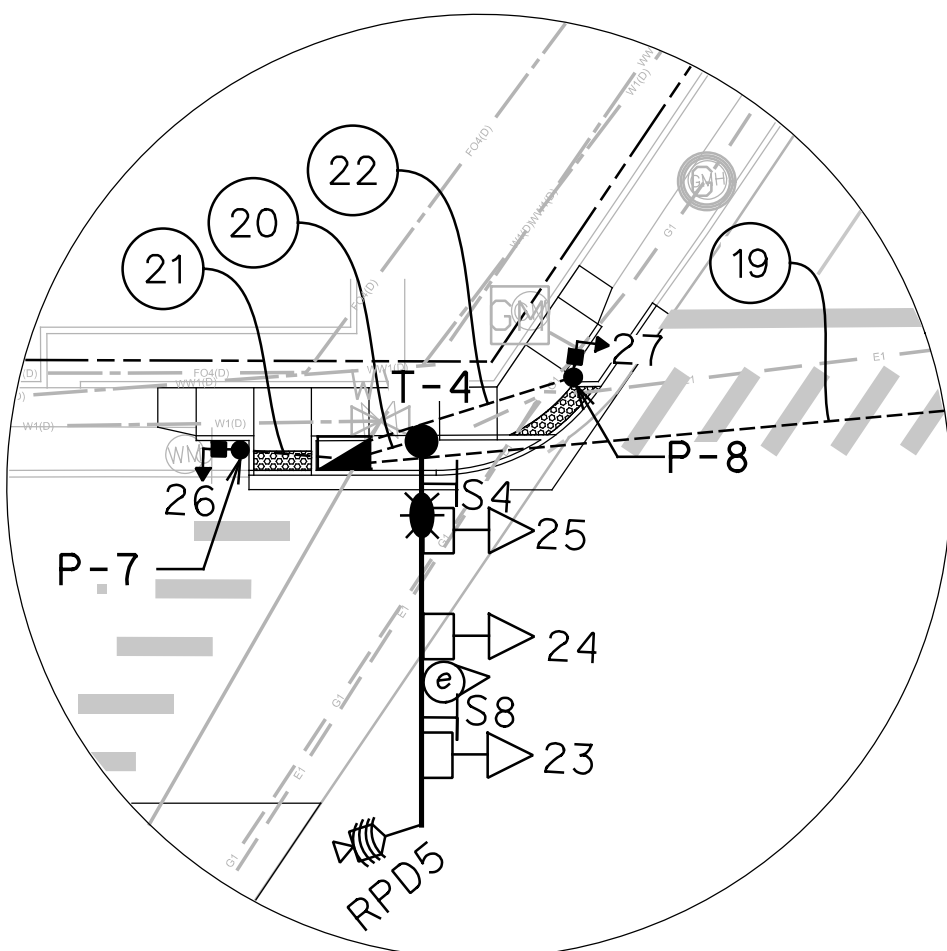
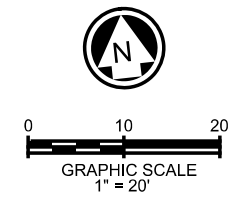

---NOT FOR CONSTRUCTION---

THIS DOCUMENT HAS BEEN
 RELEASED FOR THE PURPOSE
 OF INTERIM REVIEW UNDER
 THE AUTHORITY OF
 ZEGEYE Z. KEBEDE, P.E. 121726
 IT IS NOT TO BE USED FOR
 CONSTRUCTION PURPOSES.
 05/05/2021
 ---NOT FOR CONSTRUCTION---

	Lockwood, Andrews & Newnam, Inc. <small>A LEO A DALY COMPANY</small>	<small>TBPE Firm No.2614</small> <small>1320 S. UNIVERSITY DRIVE,</small> <small>UNIVERSITY CENTER II, SUITE 450</small> <small>FORT WORTH, TEXAS 76107</small> <small>(817) 820-0420</small>	
<h3>CONDUIT RUN DETAILS</h3>			
SHEET 1 OF 2			
REVISIONS	FED. RD. DIV. NO. 6	STATE AID PROJECT NO. SEE TITLE SHEET	SHEET NO. 93
	STATE TEXAS	DISTRICT FTW	COUNTY TARRANT
	CONTROL 0902	SECTION 90	JOB 119 192
	HIGHWAY NO. McCART		

5/5/2021 1:10:09 PM
 c:\projectwise\zkebede@lan-inc.com\d0775534\McCart Signal Corner Details 2.dgn

SIGNAL LEGEND	
T-1 ●	MAST ARM POLE
1 ◁	SIGNAL HEAD
P-1 ●	PED POLE / HEAD
◻	EXIST. CONTROLLER
◼	TYPE D GROUND BOX
⊗	PTZ CAMERA
⊙	PEDESTAL SERVICE
★	LED LUMINAIRE (250 W HPS EQU)
RPD1 ●	RADAR PRESENCE DETECTOR
⊙	OPTICOM DETECTOR
① - - -	CONDUIT RUN
⊥	OVERHEAD SIGN
∅2	PHASE NUMBER
→	TRAFFIC FLOW ARROW

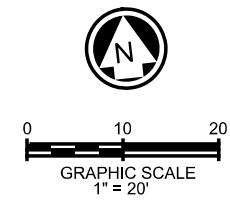

SOUTHWEST CORNER

SOUTHEAST CORNER

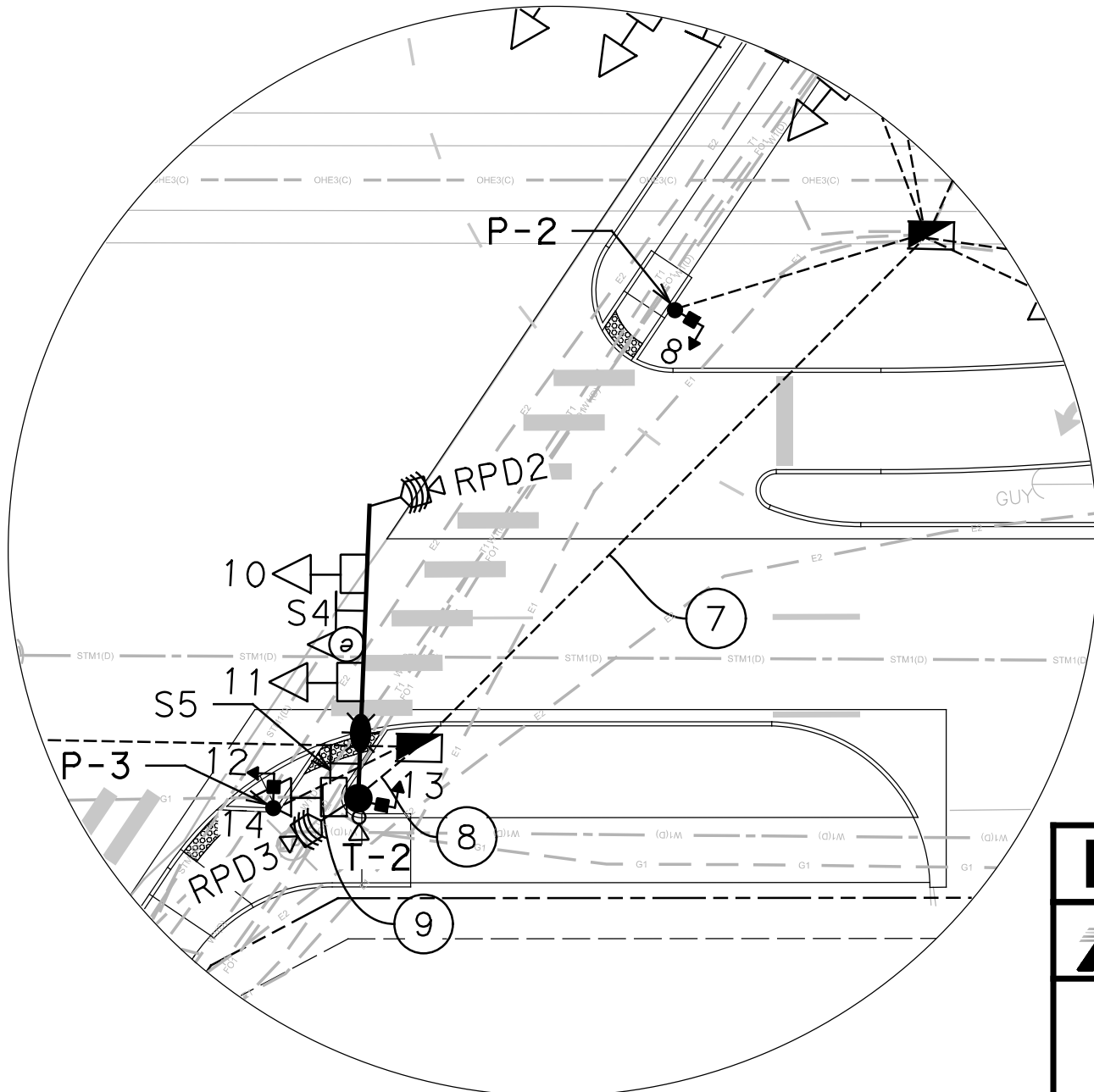
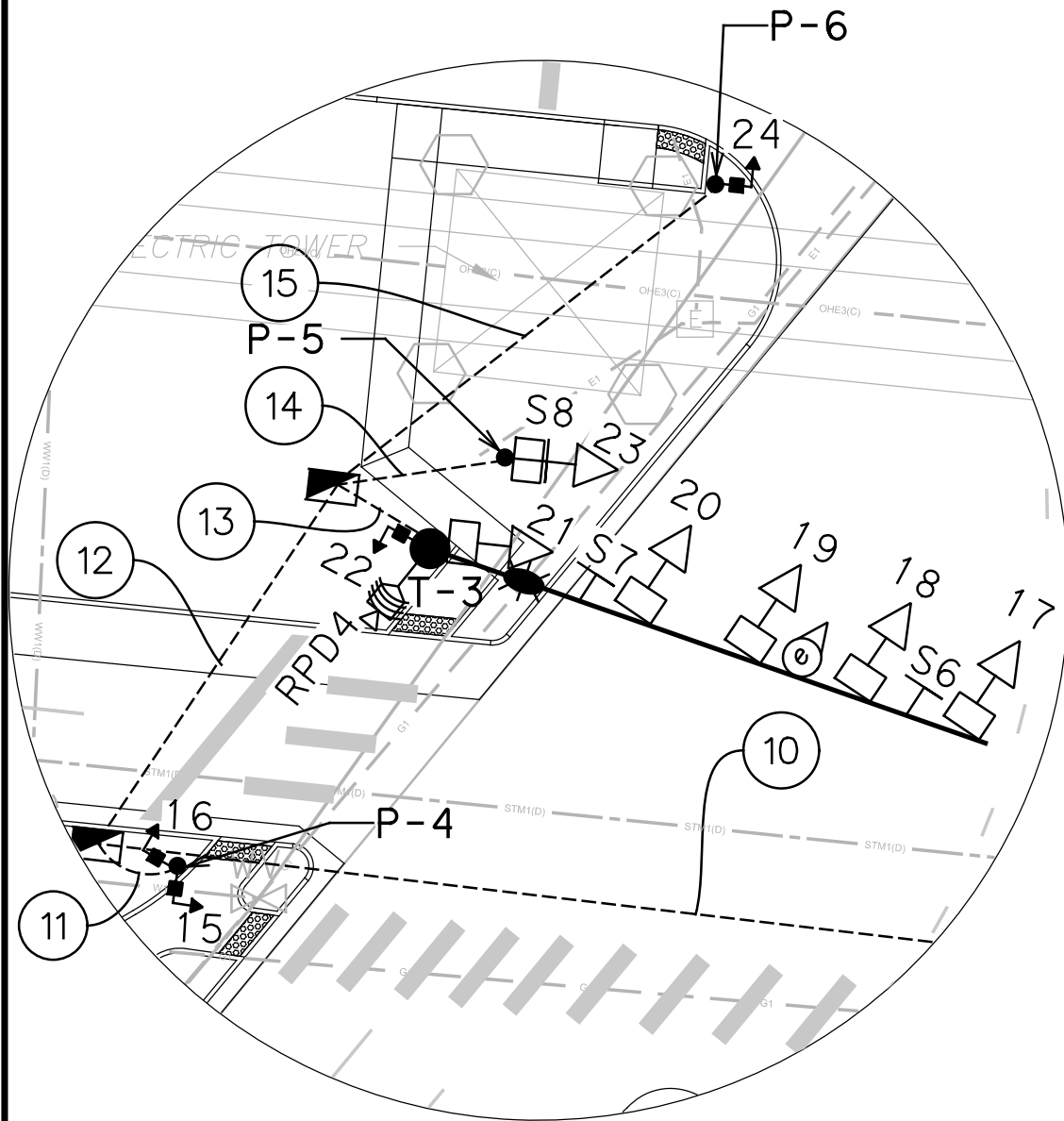

---NOT FOR CONSTRUCTION---

THIS DOCUMENT HAS BEEN
 RELEASED FOR THE PURPOSE
 OF INTERIM REVIEW UNDER
 THE AUTHORITY OF
 ZEGEYE Z. KEBEDE, P.E. 121726
 IT IS NOT TO BE USED FOR
 CONSTRUCTION PURPOSES.
 05/05/2021
 ---NOT FOR CONSTRUCTION---

LAN Lockwood, Andrews & Newnam, Inc. TBPE Firm No. 2614
 A LEON A DALY COMPANY 1320 S. UNIVERSITY DRIVE,
 UNIVERSITY CENTER II, SUITE 450
 FORT WORTH, TEXAS 76107
 (817) 820-0420



CONDUIT RUN DETAILS

SHEET 2 OF 2

REVISIONS	FED. RD. DIV. NO.	STATE AID PROJECT NO.		SHEET NO.
		6	SEE TITLE SHEET	
	STATE	DISTRICT	COUNTY	
	TEXAS	FTW	TARRANT	
	CONTROL	SECTION	JOB	HIGHWAY NO.
	0902	90	119	McCART
	0902	90	192	

SUMMARY OF CONDUIT AND CABLES												
RUN NO.	CONDUIT SIZE & INSTALLATION T-TRENCH B-BORE	LENGTH (FT)	#6 AWG BARE	#6 XHHW (POWER)	#8 AWG BARE	#8 XHHW (ILLUM)	20C 14 AWG SIGNAL	7C 14 AWG SIGNAL/ PED	*2C 12 AWG APS	RADAR CABLE	OPTICOM CABLE	PTZ CABLE
1	2"-T	15	1	2								
2	2"-T	15			1	4						
3	3"-T	30			1		2	5	6	3	2	1
	3"-T	30			1		2	5	6	3	2	
	3"-T	30			-	-	-	-	-	-	-	-
4	3"-T	25			1		1			1	1	
5	3"-T	40			1			1	1			
6	3"-T	30			1			1	1			
7	3"-B	90			1	2	2	4	6	3	2	1
8	3"-T	10			1	4	1		1	2	1	1
9	3"-T	20			1			1	1			
10	3"-B	165			1	2	1	3	4	1	1	
11	3"-T	10			1			1	2			
12	3"-B	50			1	2	1	2	2	1	1	
13	3"-T	10			1	2	1		1	1	1	
14	3"-T	20			1			1				
15	3"-T	50			1			1	1			
16	3"-B	105			1		1	4	4	2	1	
17	3"-T	15			1			1	1			
18	3"-T	10			1			1	1			
19	3"-B	175			1	2	1	2	2	2	1	
20	3"-T	10			1	2	1			2	1	
21	3"-T	15			1			1	1			
22	3"-T	25			1			1	1			
TOTAL (FT)			15	30	950	1100	850	2260	2675	1300	850	130

RADAR PRESENCE DETECTION ZONE				
RADAR NO.	MOUNTING LOCATION	MOUNTING HEIGHT (FT)	ZONE LOCATIONS	PHASE (S) SERVED
RPD1	MAST ARM T-1	20	STOP BAR	Ø6
RPD2	MAST ARM T-2	20	STOP BAR	Ø1
RPD3	SIGNAL POLE T-2	20	STOP BAR	Ø3, Ø8
RPD4	SIGNAL POLE T-3	20	STOP BAR	Ø2
RPD5	MAST ARM T-4	20	STOP BAR	Ø5
RPD6	MAST ARM T-1	20	STOP BAR	Ø4, Ø7

RPD PRESENCE DETECTION clikok 656

SENSOR 1	PH 6	RPD1
SENSOR 2	PH 1	RPD2
SENSOR 3	PH 3, PH 8	RPD3
SENSOR 4	PH 2	RPD4
SENSOR 5	PH 5	RPD5
SENSOR 6	PH 4, PH 7	RPD6

CONTROLLER

DETECTOR CHANNEL	1	2	3	4	5	6	7	8
PHASE ASSIGNMENT	PH 1	PH 2L,C	PH 3L	PH 4L,C	PH 5	PH 6L,C	PH 7	PH 8L,C
MATRIX OUTPUT CHANNEL	1	2	3	4	5	6	7	8
DETECTOR CHANNEL	9	10	11	12	13	14	15	16
PHASE ASSIGNMENT		PH 2R	PH 3R	PH 4R		PH 6R		PH 8R
MATRIX OUTPUT CHANNEL		10	11	12		14		16

CABLE QUANTITIES INSIDE POLES (LF)											
POLE NO.	#6 AWG BARE	#6 XHHW (POWER)	#8 AWG BARE	#8 XHHW (ILLUM)	5C 14 AWG SIGNAL	4C 14 AWG PED	*2C 12 AWG APS	RADAR CABLE	OPTICOM CABLE	PTZ CABLE	
T-1	-	-	-	-	305	-	-	25	60	-	
T-2	-	-	-	40	110	10	5	85	40	30	
T-3	-	-	-	40	290	10	5	25	60	-	
T-4	-	-	-	40	135	-	-	85	40	-	
P-1	-	-	-	-	20	10	5	-	-	-	
P-2	-	-	-	-	-	10	5	-	-	-	
P-3	-	-	-	-	-	10	5	-	-	-	
P-4	-	-	-	-	-	20	10	-	-	-	
P-5	-	-	-	-	20	-	-	-	-	-	
P-6	-	-	-	-	-	10	5	-	-	-	
P-7	-	-	-	-	-	10	5	-	-	-	
P-8	-	-	-	-	-	10	5	-	-	-	
P-9	-	-	-	-	-	10	5	-	-	-	
P-10	-	-	-	-	-	10	5	-	-	-	
TOTAL QTY INSIDE POLE	0	0	0	120	880	120	60	220	200	30	

NOTE: OPTICOM AND PTZ CAMERA WIRING ARE SUPPLIED BY THE CITY AND INSTALLED BY THE CONTRACTOR.
* USE 2C #12 AWG APS FOR PEDESTRIAN SIGNAL.

CONDUIT SUMMARY			
DESCRIPTION	UNIT	QTY	
COND (PVC) (SCH80) (2") TRENCH	LF	40	
COND (PVC) (SCH80) (3") TRENCH	LF	380	
COND (PVC) (SCH80) (2") BORE	LF	105	
COND (PVC) (SCH80) (3") BORE	LF	585	

RECOMMENDED MINIMUM PEDESTRIAN TIMING				
MIN WALK TIME = 7 SEC (FOR ALL Øs)				
FLASHING DO NOT WALK	PHASE / TIME (SEC)			
	SIGNAL HEADS 14, 15	SIGNAL HEADS 16, 22, 24, 28	SIGNAL HEADS 29, 31	SIGNAL HEADS 8, 9, 13, 30
	Ø2	Ø4	Ø6	Ø8
	34	16	41	16
TOTAL TIME	41	23	48	23

SUMMARY OF GROUND BOXES	
GROUND BOX	NUMBER (EA)
TYPE D W / APRON	6
TOTAL	6

---NOT FOR CONSTRUCTION---

THIS DOCUMENT HAS BEEN RELEASED FOR THE PURPOSE OF INTERIM REVIEW UNDER THE AUTHORITY OF ZEGEYE Z. KEBEDE, P.E. 121726 IT IS NOT TO BE USED FOR CONSTRUCTION PURPOSES. 05/05/2021

---NOT FOR CONSTRUCTION---

LAN Lockwood, Andrews & Newnam, Inc. A LEON A DALY COMPANY
 TBPE Firm No.2614
 1320 S. UNIVERSITY DRIVE,
 UNIVERSITY CENTER II, SUITE 450
 FORT WORTH, TEXAS 76107
 (817) 820-0420

Texas Department of Transportation

TRAFFIC SIGNAL CHARTS

SHEET 1 OF 2

REVISIONS	FED. RD. DIV. NO.	STATE AID PROJECT NO.		SHEET NO.
	6	SEE TITLE SHEET		95
	STATE	DISTRICT	COUNTY	
	TEXAS	FTW	TARRANT	
CONTROL	SECTION	JOB	HIGHWAY NO.	
0902	90	119	McCART	
0902	90	192		

SIGNAL POLE CHART																																
POLE NUMBER	T-1						P-1	P-2	T-2						P-3	P-4	T-3						P-5	P-6	T-4			P-7	P-8	P-9	P-10	P-11
POLE HEIGHT	19'						15'	10'	30'						10'	10'	30'						15'	10'	30'			10'	10'	30'	10'	30'
MAST ARM LENGTH	65'						-	-	36'						-	-	65'						-	-	40'			-	-	-	-	-
TxDOT FOUNDATION TYPE	48-A						24-A	24-A	36-A						24-A	24-A	48-A						24-A	24-A	36-A			24-A	24-A	24-A	24-A	30-A
WITH LUMINAIRES	NO						NO	NO	YES						NO	NO	YES						NO	NO	YES			NO	NO	NO	NO	YES
SIZE OF LENS	12"						12"	-	12"						-	-	12"						12"	-	12"			-	-	-	-	-
SIGNS ON MAST ARM	S1, S2						-	-	S4, S5						-	-	S6, S7						-	-	S9, S10			-	-	-	-	-
SIGNAL TYPE	V3A	V3A	V3	V3	V3	V3B	V3B	G	G	V3	V3	V3	G	G	G	G	V3A	V3	V3	V3	V3B	G	V3B	G	V3	V3	V3	G	G	G	G	
SIGNAL FACE NO.	1	2	3	4	5	6	7	8	9	10	11	12	13	14	15	16	17	18	19	20	21	22	23	24	25	26	27	28	29	30	31	
LED SIGNAL INDICATIONS	<-R-	<-R-	R	R	R	<-R-	<-R-	DW	DW	R	R	R	DW	DW	DW	DW	<-R-	R	R	R	<-R-	DW	<-R-	DW	R	R	R	DW	DW	DW	DW	
	<-Y-	<-Y-	Y	Y	Y	<-SY/FY-	<-SY/FY-			Y	Y	Y					<-Y-	Y	Y	Y	<-SY/FY-	<-SY/FY-		Y	Y	Y						
	<-G-	<-G-	G	G	G	<-G-	<-G-	W	W	⬆	G	G	W	W	W	W	<-G-	G	G	G	<-G-	W	<-G-	W	⬆	G	G	W	W	W	W	

NOTE: P-11 IS RELOCATED LIGHTING POLE WITH 30" DIAMETER BY 8' LONG DRILLED SHAFT FOUNDATIONS. FOUNDATION IS PAID UNDER PAY ITEM 416. ANY ADDITIONAL WIRE REQUIRED FOR THE RELOCATION OF THE LIGHTING POLES SHALL BE SUBSIDIARY TO ITEM 610.

SUGGESTED APS PROGRAMMING CHART				
APS	SIGN	STREET NAME BEING CROSSED	CROSS SIDE STREET NAME	APS UNIT PROGRAMMING SETTING
P-1	R10-3eR	ALTAMESA BOULEVARD	McCART AVENUE	
P-2	R10-3eR	ALTAMESA BOULEVARD	McCART AVENUE	REGULAR PUSH SPEECH MESSAGE = "WAIT"
T-2	R10-3eL	ALTAMESA BOULEVARD	McCART AVENUE	WALK INDICATION SPEECH MESSAGE = " (STREET NAME BEING CROSSED) ,
P-3	R10-3eL	McCART AVENUE	ALTAMESA BOULEVARD	WALK SIGN IS ON TO CROSS (STREET NAME BEING CROSSED) "
P-4	R10-3eR	McCART AVENUE	ALTAMESA BOULEVARD	COUNTDOWN SPEECH MESSAGE = OFF
P-4	R10-3eR	ALTAMESA BOULEVARD	McCART AVENUE	EXTENDED PUSH SPEECH MESSAGE = " WAIT TO CROSS (STREET NAME
T-3	R10-3eL	ALTAMESA BOULEVARD	McCART AVENUE	BEING CROSSED) AT (CROSS SIDE STREET NAME) "
P-6	R10-3eL	ALTAMESA BOULEVARD	McCART AVENUE	
P-7	R10-3eR	ALTAMESA BOULEVARD	McCART AVENUE	
P-8	R10-3eR	McCART AVENUE	ALTAMESA BOULEVARD	
P-9	R10-3eR	ALTAMESA BOULEVARD	McCART AVENUE	
P-10	R10-3eR	McCART AVENUE	ALTAMESA BOULEVARD	

---NOT FOR CONSTRUCTION---

THIS DOCUMENT HAS BEEN RELEASED FOR THE PURPOSE OF INTERIM REVIEW UNDER THE AUTHORITY OF ZEGEYE Z. KEBEDE, P.E. 121726 IT IS NOT TO BE USED FOR CONSTRUCTION PURPOSES. 05/05/2021

---NOT FOR CONSTRUCTION---

ELECTRICAL SERVICE DATA											
ELEC. SERVICE ID	ELECTRICAL SERVICE DESCRIPTION	SERVICE CONDUIT SIZE	SERVICE CONDUCTORS NO./SIZE	SAFETY SWITCH AMPS	MAIN CKT. BRK. POLE/AMPS	TWO-POLE CONTACTOR AMPS	PANELBD/LOADCENTER AMP RATING (MIN.)	BRANCH CIRCUIT ID	BRANCH CKT. BKR. POLE/AMPS	BRANCH CIRCUIT AMPS	KVA LOAD
1	ELC SRV TY D 120/240 060 (NS)AL(E)PS(U)	2"	3/#6	N/A	2P/60	30	100	A-SIGNAL B-LUMINAIRES	1P/50 2P/20	40 7.5	7.0

LAN Lockwood, Andrews & Newnam, Inc. A LEONARD COMPANY
 TBPE Firm No.2614
 1320 S. UNIVERSITY DRIVE,
 UNIVERSITY CENTER II, SUITE 450
 FORT WORTH, TEXAS 76107
 (817) 820-0420



TRAFFIC SIGNAL CHARTS

SHEET 2 OF 2

REVISIONS	FED. RD. DIV. NO.	STATE AID PROJECT NO.		SHEET NO.
	6	SEE TITLE SHEET		96
	STATE	DISTRICT	COUNTY	
	TEXAS	FTW	TARRANT	
CONTROL	SECTION	JOB	HIGHWAY NO.	
0902	90	119	McCART	
0902	90	192		

LOAD SWITCH OUTPUT ASSIGNMENT

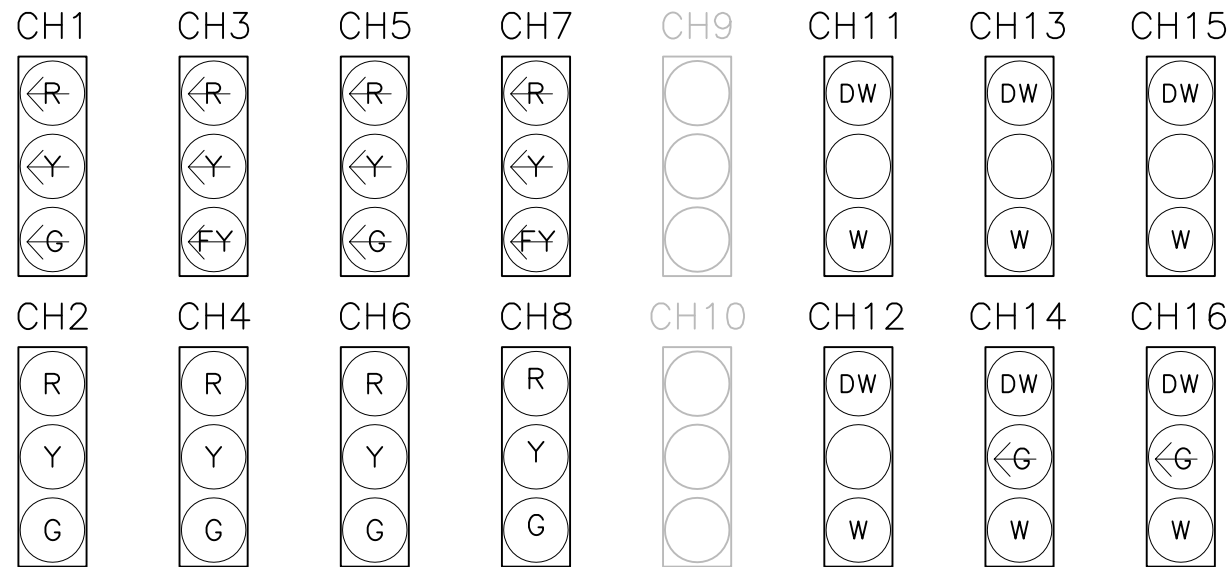

SIGNAL DETECTOR ATTRIBUTE / CHANNEL												
	1	2	3	4	5	6	7	8	9	10	11	12
352i ATC								PED OVL 11	PED OVL 13	PED OVL 15	EV NB	EV WB
								DET 15	DET 17	DET 19	DET 21	DET 23
								PED OVL 12	PED OVL 14	PED OVL 16	EV SB	EV EB
								DET 16	DET 18	DET 20	DET 22	DET 24

ALL VEHICULAR TRAFFIC DETECTION WILL BE ON SDLC

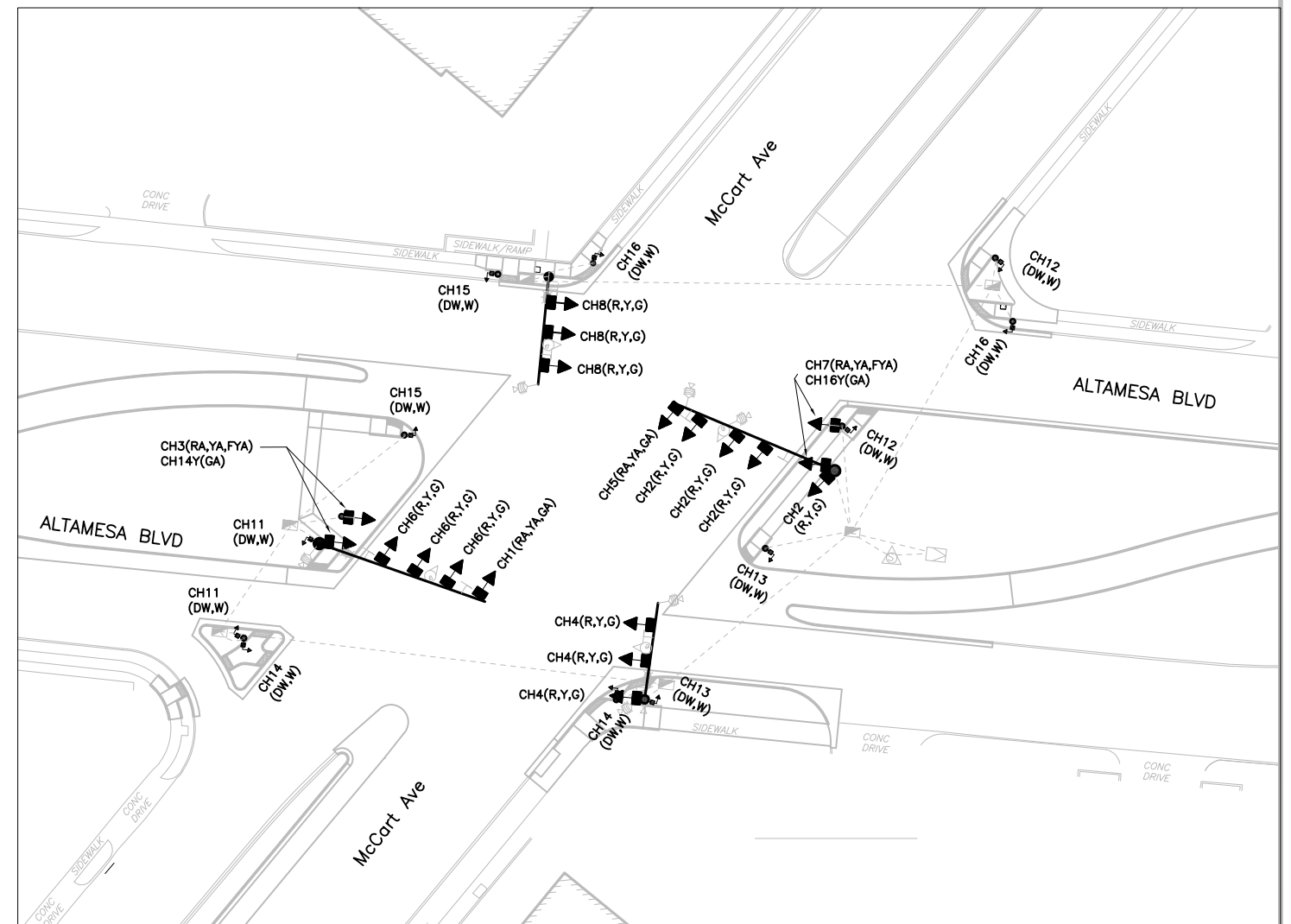

5001 JAMES AVENUE
FORT WORTH, TX 76115

PHONE: (817) 392-8656
FAX: (817) 392-2533

LEGEND

- ➔ SIGNAL HEAD
- PED POLE
- ➔ PED HEAD
- MAST ARM

SCALE

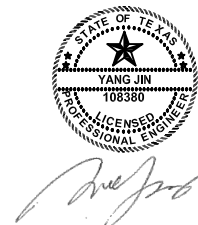
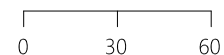

CITY OF FORT WORTH

DEPARTMENT OF TRANSPORTATION AND PUBLIC WORKS
TRAFFIC MANAGEMENT DIVISION

McCart Ave & Altamesa Blvd

CHANNEL ASSIGNMENT DRAWING

NOTES	NAME	DATE
DRAWN BY:	SAMSON	4-29-21
CHECKED BY:	SHANNON	4-29-21
REVIEWED BY:	SHANNON	4-29-21
APPROVED BY:	YANG JIN	4-29-21
CAD FILE NO. :		
SHEET NO. :		97

TYPICAL SIGNAL HEADS MOUNTING
(ASTRO-BRAC TYPE OR EQUAL)

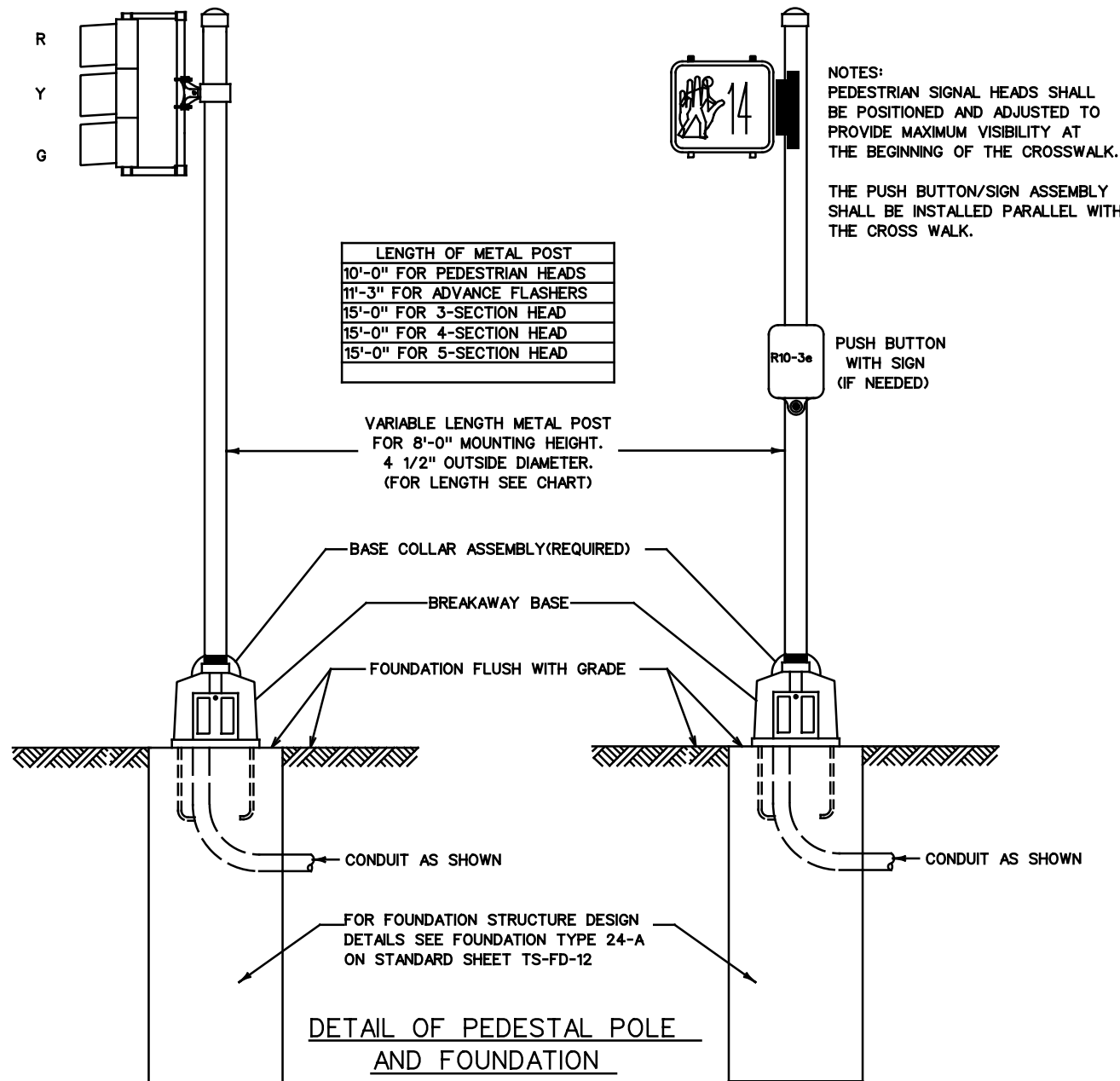

DETAIL OF PEDESTAL POLE AND FOUNDATION

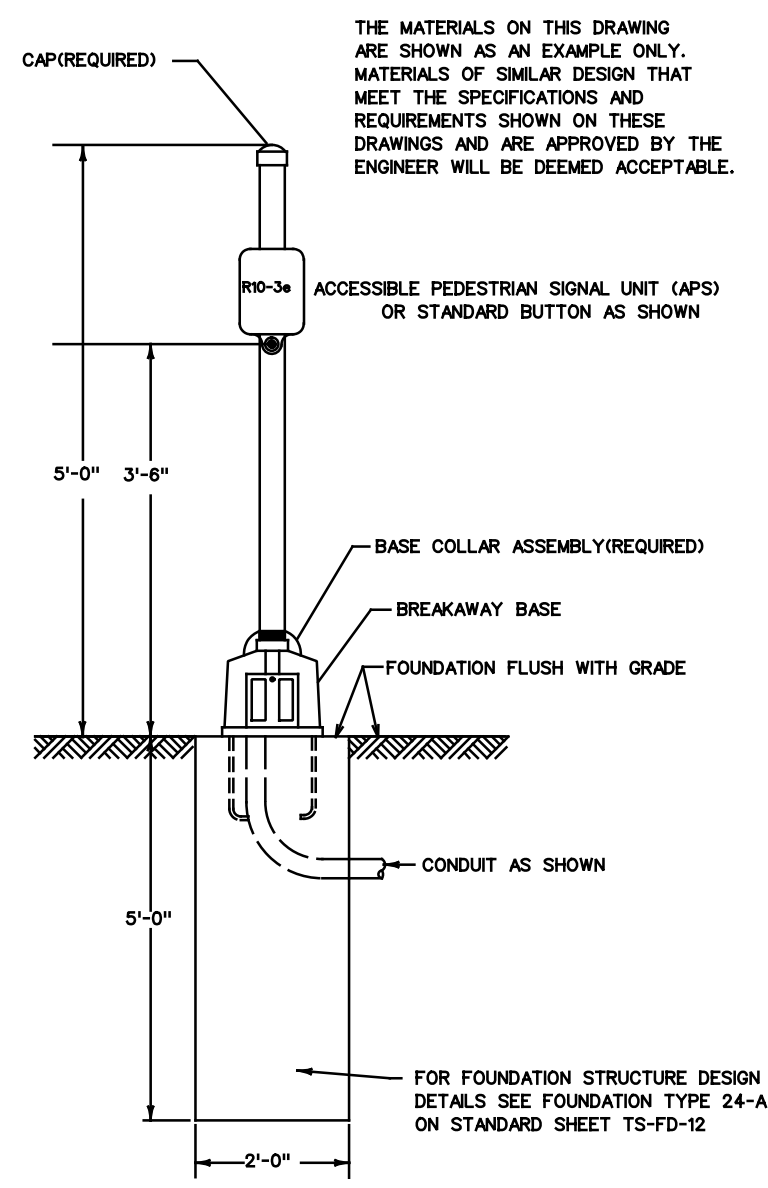

DETAIL OF PEDESTRIAN POLE ASSEMBLY WITH ACCESSIBLE PEDESTRIAN SIGNAL UNIT (APS) OR STANDARD BUTTON

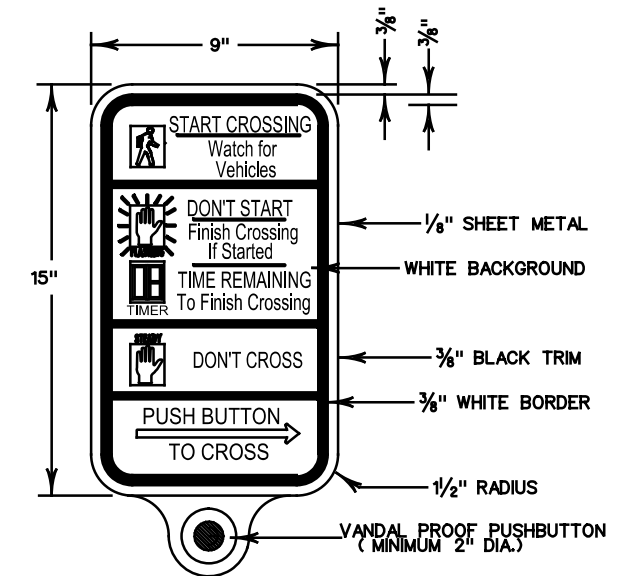

PUSH BUTTON & SIGN (R10-3e)

THE 9"X15" SIGN SHOWN SHALL BE USED ON MAST ARM POLES AND ON PEDESTAL POLES. THE PUSH BUTTON SHALL BE INSTALLED 3'-6" ABOVE GROUND LEVEL.

- NOTES:
1. ALL SIGNAL HEADS SHALL BE FROM THE SAME MANUFACTURER, ALUMINUM WITH LED LENSES, AND BE MOUNTED WITH "ASTRO BRACS" UNLESS OTHERWISE SHOWN IN PLANS.
 2. PROVIDE ALL LED TRAFFIC SIGNAL LAMP UNITS, AS WELL AS THE VARIOUS COMPONENTS OF THE SIGNAL HEADS TO BE INSTALLED WITHIN THIS PROJECT.
 3. THE SIGNAL HEAD TO MAST ARM CONNECTION MUST ALLOW FOR ADJUSTMENT ABOUT THE HORIZONTAL AND VERTICAL AXIS.

---NOT FOR CONSTRUCTION---

THIS DOCUMENT HAS BEEN RELEASED FOR THE PURPOSE OF INTERIM REVIEW UNDER THE AUTHORITY OF ZEGEYE Z. KEBEDE, P.E. 121726 IT IS NOT TO BE USED FOR CONSTRUCTION PURPOSES. 05/05/2021

---NOT FOR CONSTRUCTION---

TYPICAL DETAIL OF SIGNAL HEAD AND SIGN MOUNTING
SEE PROPOSED SIGNAL LAYOUT

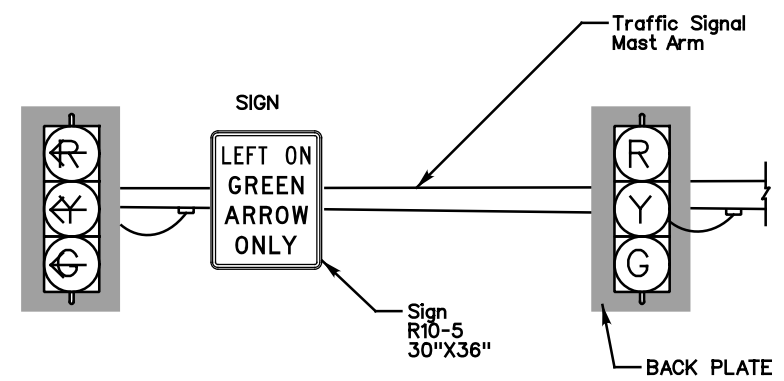

TYPICAL DETAIL LED COUNTDOWN PEDESTRIAN SIGNAL HEAD MODULE

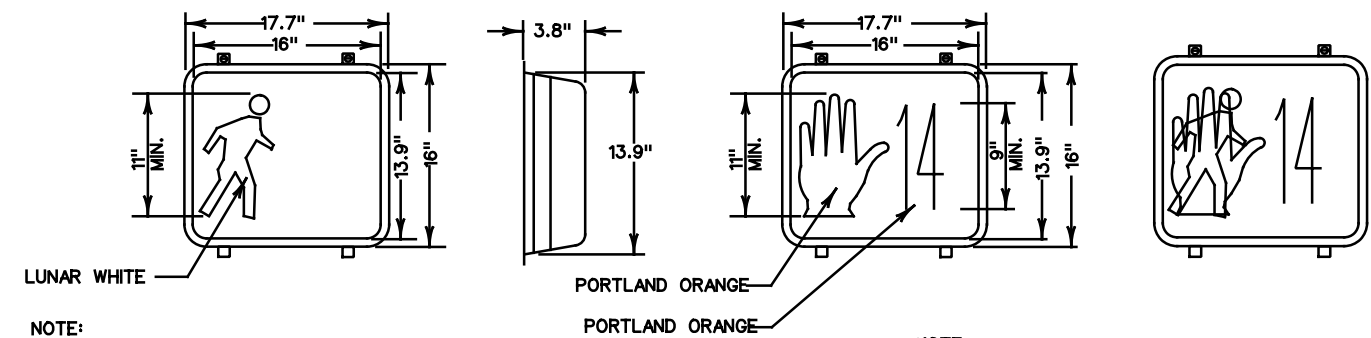

- NOTE: OTHER UNITS OF DIFFERENT DESIGN/CONFIGURATION WHICH MEET THE SPECIFICATIONS AND ARE APPROVED BY THE ENGINEER WILL BE DEEMED ACCEPTABLE.
- NOTE: CLAM SHELL MOUNTING HARDWARE MAY BE USED, AS APPROVED BY THE ENGINEER.

©2021 by Texas Department of Transportation; all rights reserved

Lockwood, Andrews & Newnam, Inc.
A LEON A DALY COMPANY

TBPE Firm No. 2614
1320 S. UNIVERSITY DRIVE,
UNIVERSITY CENTER II, SUITE 450
FORT WORTH, TEXAS 76107
(817) 820-0420

Texas Department of Transportation

PEDESTRIAN SIGNAL DETAILS

REVISIONS	FED. RD. DIV. NO.	STATE AID PROJECT NO.		SHEET NO.
		6	SEE TITLE SHEET	
	STATE	DISTRICT	COUNTY	
	TEXAS	FTW	TARRANT	
	CONTROL	SECTION	JOB	HIGHWAY NO.
	0902	90	119	McCART
	0902	90	192	

5/5/2021 1:10:41 PM c:\projectwise\zkebede@lan-inc.com\d0775534\SIGNAL DETAILS.dgn

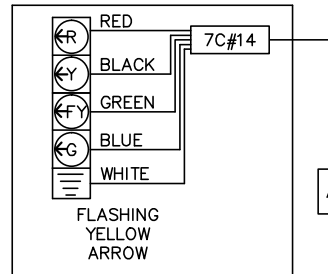
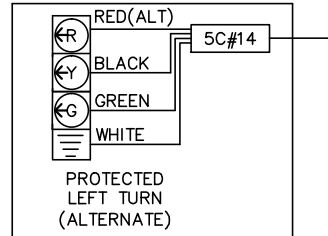
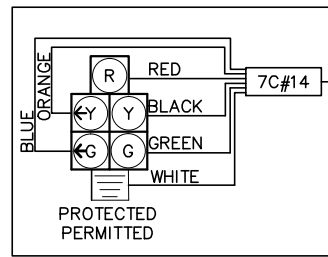

NOTES:
 ALL BONDING AND GROUNDING SHALL BE MADE WITH THE GROUND RODS AND THE EQUIPMENT GROUNDING CONDUCTOR.
 SERVICE EQUIPMENT SHALL BE INSTALLED ACCORDING TO THE ELECTRIC SERVICE PROVIDER ELECTRIC AND CITY OF FT. WORTH ELECTRICAL CODES.

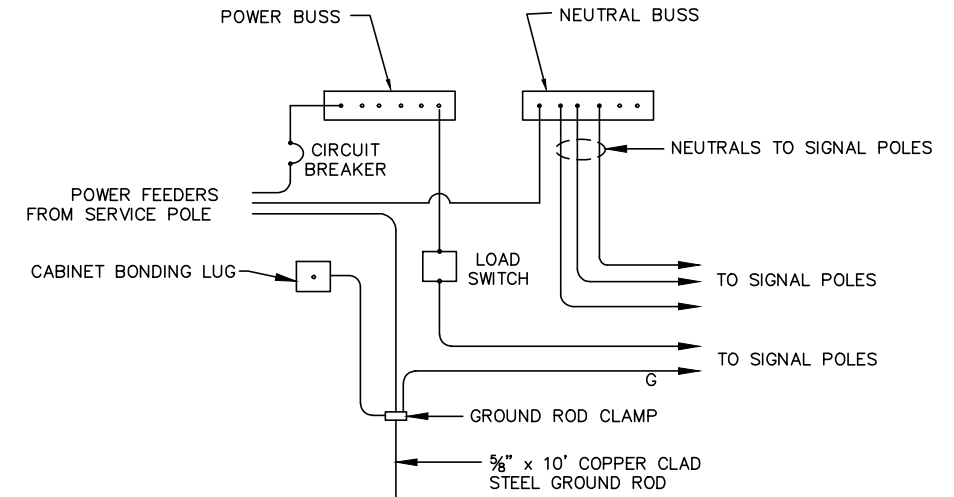

CONNECTIONS AT SIGNAL CABINETS

POLE TO CABINET WIRING COLOR CHART FOR 20 CONDUCTOR CABLE	
SIGNAL NEUTRAL	WHITE
MAIN ST. OR CROSS ST. - RED	RED
MAIN ST. OR CROSS ST. - YELLOW	BLACK
MAIN ST. OR CROSS ST. - GREEN	GREEN
MAIN ST. OR CROSS ST. - LEFT TURN RED	RED/WHITE
MAIN ST. OR CROSS ST. - LEFT TURN YELLOW ARROW	BLACK/WHITE
MAIN ST. OR CROSS ST. - LEFT TURN GREEN ARROW	GREEN/WHITE
DW - MAIN ST.	ORANGE/RED
W - MAIN ST.	ORANGE
DW - CROSS ST.	RED/BLACK
W - CROSS ST.	GREEN/BLACK
S.P.A.R.E. RED NEAR SIDE HEAD	RED/GREEN
S.P.A.R.E. YELLOW	BLACK/RED
S.P.A.R.E. GREEN	GREEN/RED
S.P.A.R.E. FLASHING YELLOW ARROW	ORANGE/BLACK
S.P.A.R.E.	BLUE/WHITE

NOTE:
 WRAP COLORED ELECTRICAL TAPE ON BOTH ENDS OF EACH 20 CONDUCTOR CABLE (AT CABINET AND AT SIGNAL POLE) AS FOLLOWS:
 NORTH BOUND = GREEN,
 SOUTH BOUND = RED,
 WEST BOUND = BLUE AND
 EAST BOUND = YELLOW.

---NOT FOR CONSTRUCTION---

THIS DOCUMENT HAS BEEN RELEASED FOR THE PURPOSE OF INTERIM REVIEW UNDER THE AUTHORITY OF ZEGEYE Z. KEBEDE, P.E. 121726 IT IS NOT TO BE USED FOR CONSTRUCTION PURPOSES. 05/05/2021
 ---NOT FOR CONSTRUCTION---

NOTE: USE 2C#12 FOR APS SIGNAL IN STEAD OF 3C#14 FOR VOLTAGE DROP PURPOSES.

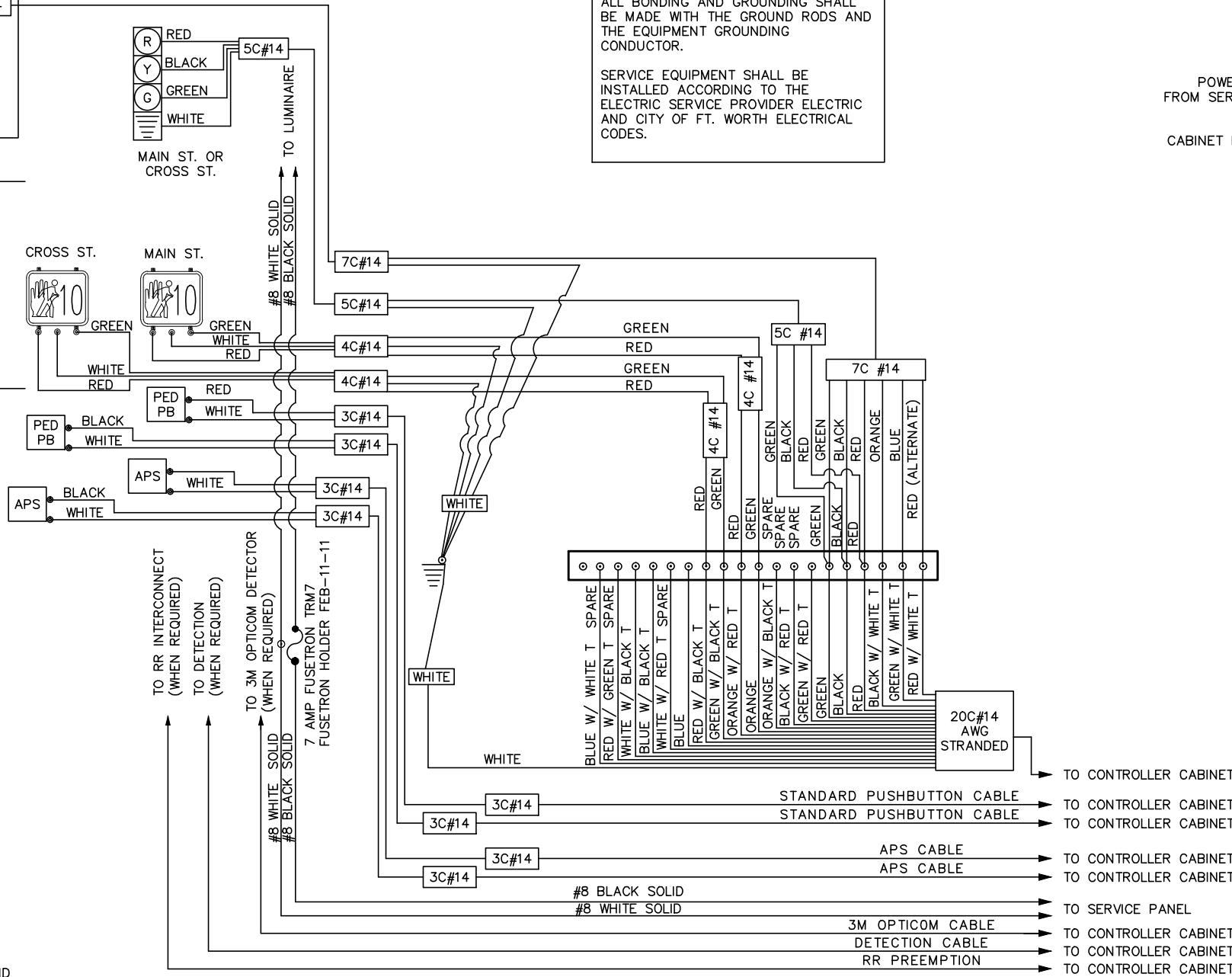

TYPICAL POLE WIRING SCHEMATIC

NOTE: ALL WIRING CABLES SHALL BE AS SHOWN UNLESS NOTED OTHERWISE IN THE DRAWINGS.

NO SPLICES ARE ALLOWED

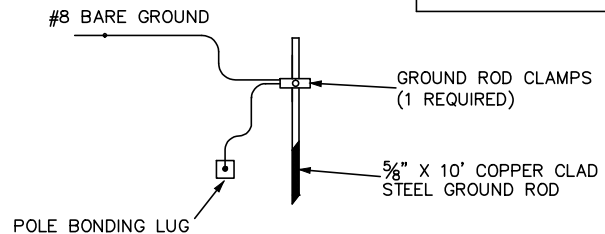

CONNECTIONS AT POLE BASE

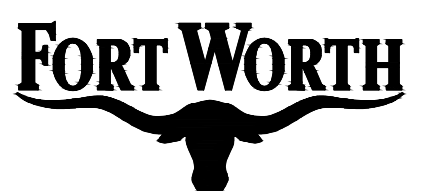

CITY OF FORT WORTH, TEXAS
**TRAFFIC SIGNAL
 WIRING CONNECTION DETAILS**

REVISED: 11-19-2015

34 41 10-D604

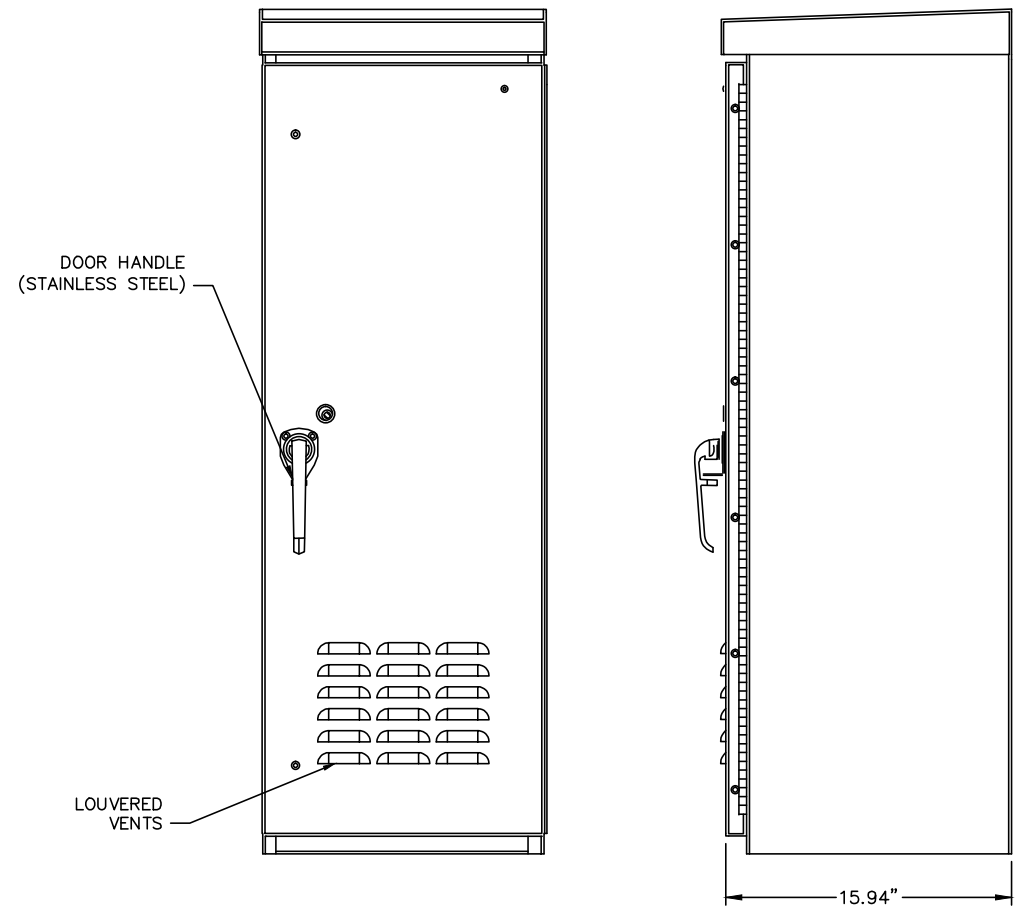

FRONT AND SIDE VIEW

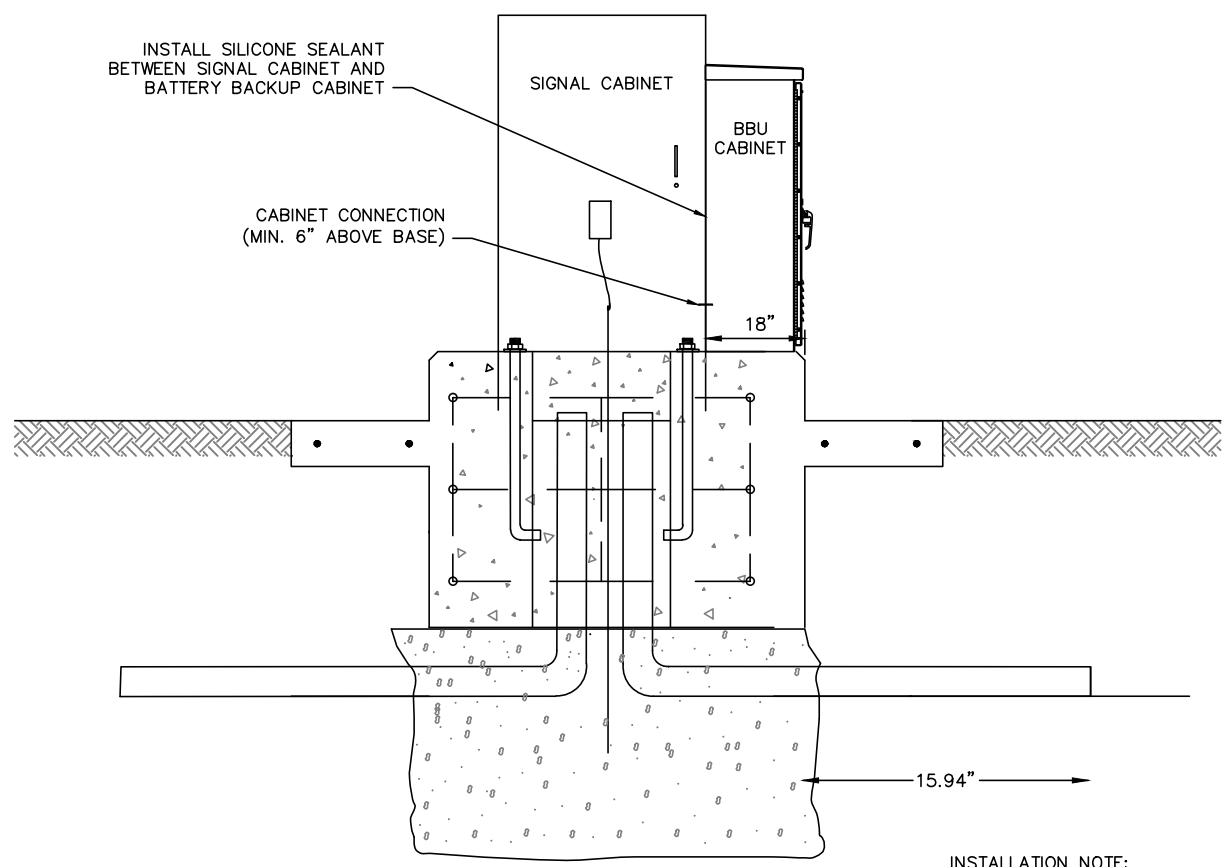

CABINET MOUNTED TO TRAFFIC SIGNAL CONTROLLER CABINET

INSTALLATION NOTE:

1. MOUNTING HOLES MUST BE DRILLED ON SITE AND MOUNTED WITH 6 SETS OF 1/4"-20 18-8 STAINLESS STEEL HEX HEAD BOLTS AND NUTS ASSEMBLY (SUPPLIED WITH SYSTEM).
2. BOLT SPACING SHOWN IN FRONT VIEW SHOWS TYPICAL LOCATIONS. LOCATION OF BOLTS MAY VARY TO ACCOMMODATE CONFLICTS.
3. INSPECTOR MUST APPROVE MOUNTING PRIOR TO INSTALLATION TO ENSURE PEDESTRIAN PATHWAYS ARE NOT BLOCKED AND THE MINIMUM CLEARANCE FROM FACE OF CURB OR EDGE OF PAVEMENT IS MET.
4. REFER TO DETAIL D606 FOR CABINET FOUNDATION DETAILS.
5. INSTALL 3" HOLE SAW CUT WITH THREADED NIPPLE ON EACH SIDE FOR CONNECTION BETWEEN CABINETS. CONNECTION POINT SHALL BE A MINIMUM OF 6" ABOVE BOTTOM OF CABINET.

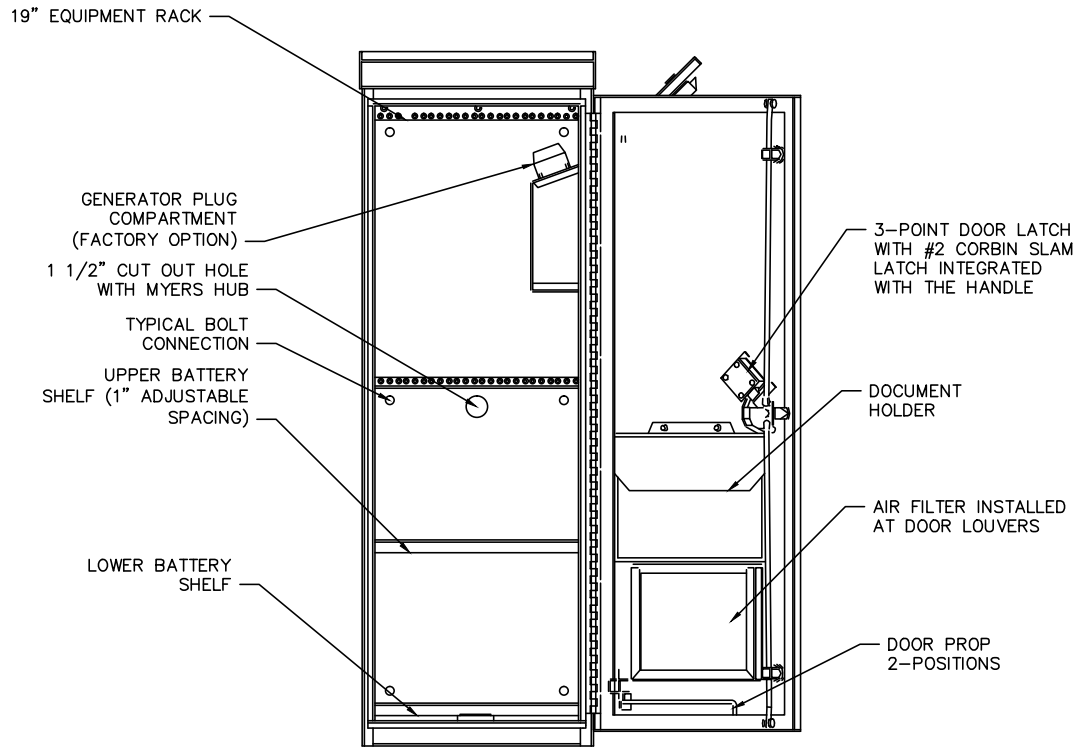

FRONT VIEW (SHOWN WITH DOOR OPENED)

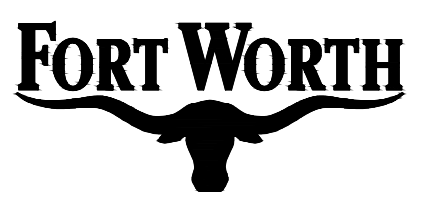

CITY OF FORT WORTH, TEXAS
**TRAFFIC SIGNAL
 BATTERY BACK UP DETAIL**

DATE: 11-19-2015

34 41 10-D620

DISCLAIMER: The use of this standard is governed by the "Texas Engineering Practice Act". No warranty of any kind is made by TxDOT for any purpose whatsoever. TxDOT assumes no responsibility for the conversion of this standard to other formats or for incorrect results or damages resulting from its use.

DATE: FILE:

FOUNDATION DESIGN TABLE

FDN TYPE	DRILLED SHAFT DIA	REINFORCING STEEL		EMBEDDED DRILLED SHAFT LENGTH-ft (4), (5), (6)			ANCHOR BOLT DESIGN (1)			FOUNDATION DESIGN LOAD (2)		TYPICAL APPLICATION	
		VERT BARS	SPIRAL & PITCH	TEXAS CONE PENETROMETER N Blows/ft			ANCHOR BOLT DIA	Fy (ksi)	BOLT CIR DIA	ANCHOR TYPE	MOMENT K-ft		SHEAR Kips
				10	15	40							
24-A	24"	4- #5	#2 at 12"	5.7	5.3	4.5	3/4"	36	12 3/4"	2	10	1	Pedestal pole, pedestal mounted controller.
30-A	30"	8- #9	#3 at 6"	11.3	10.3	8.0	1 1/2"	55	17"	2	87	3	Mast arm assembly. (see Selection Table)
36-A	36"	10- #9	#3 at 6"	13.2	12.0	9.4	1 3/4"	55	19"	2	131	5	Mast arm assembly. (see Selection Table) 30' strain pole with or without luminaire.
36-B	36"	12- #9	#3 at 6"	15.2	13.6	10.4	2"	55	21"	2	190	7	Mast arm assembly. (see Selection Table) Strain pole taller than 30' & strain pole with mast arm
42-A	42"	14- #9	#3 at 6"	17.4	15.6	11.9	2 1/4"	55	23"	2	271	9	Mast arm assembly. (see Selection Table)

NOTES:

- Anchor bolt design develops the foundation capacity given under Foundation Design Loads.
- Foundation Design Loads are the allowable moments and shears at the base of the structure.
- Foundations may be listed separately or grouped according to similarity of location and type. Quantities are for the Contractor's information only.
- Field Penetrometer readings at a depth of approximately 3 to 5 feet may be used to adjust shaft lengths.
- If rock is encountered, the Drilled Shaft shall extend a minimum of two diameters into solid rock.
- Decimal lengths in Design Table are to allow interpolation for other penetrometer values. Round to nearest foot for entry into Summary Table.

FOUNDATION SELECTION TABLE FOR STANDARD MAST ARM PLUS ILSN SUPPORT ASSEMBLIES (ft)

80 MPH DESIGN WIND SPEED	MAX SINGLE ARM LENGTH	FDN 30-A	FDN 36-A	FDN 36-B	FDN 42-A
		24' x 24'			
MAXIMUM DOUBLE ARM LENGTH COMBINATIONS	28' x 28'				
	32' x 28'				
	36' x 36'				
	40' x 36'				
100 MPH DESIGN WIND SPEED	44' x 28'				
	44' x 36'				
	24' x 24'				
	28' x 28'				
MAXIMUM DOUBLE ARM LENGTH COMBINATIONS	32' x 24'				
	32' x 24'				
	32' x 24'				
	40' x 24'				

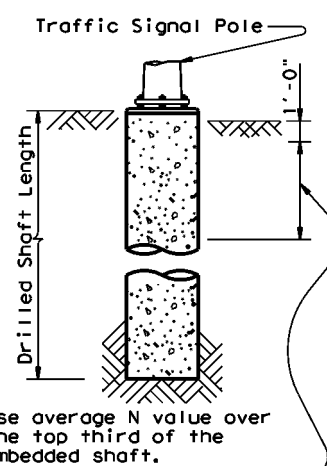

ANCHOR BOLT & TEMPLATE SIZES

BOLT DIA IN.	BOLT LENGTH	TOP THREAD	BOTTOM THREAD	BOLT CIRCLE	R2	R1
3/4"	1'-6"	3"	—	12 3/4"	7 1/8"	5 3/8"
1 1/2"	3'-4"	5"	4"	17"	10"	7"
1 3/4"	3'-10"	7"	8 1/2"	19"	11 1/4"	7 3/4"
2"	4'-3"	8"	5"	21"	12 1/2"	8 1/2"
2 1/4"	4'-9"	9"	5 1/2"	23"	13 3/4"	9 1/4"

⑦ Min dimensions given, longer bolts are acceptable.

- EXAMPLE:**
- For 80mph design wind speed, foundation 30-A can support up to a 32' arm with another arm up to 28'
 - For 100mph design wind speed, foundation 36-A can support a single 36' mast arm.

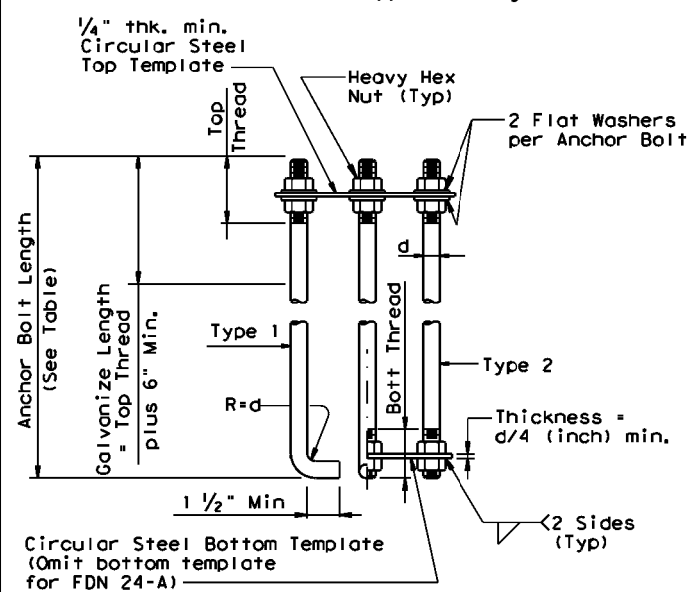

ANCHOR BOLT ASSEMBLY

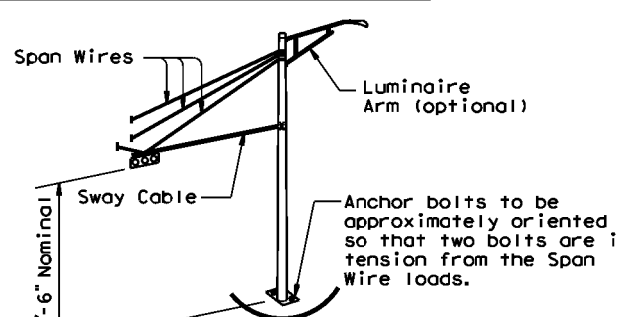

TYPICAL STRAIN POLE ASSEMBLY

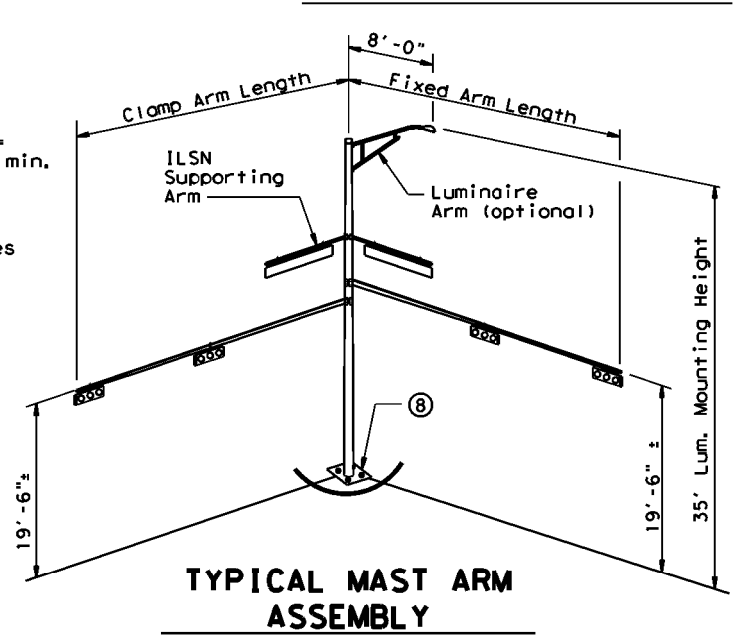

TYPICAL MAST ARM ASSEMBLY

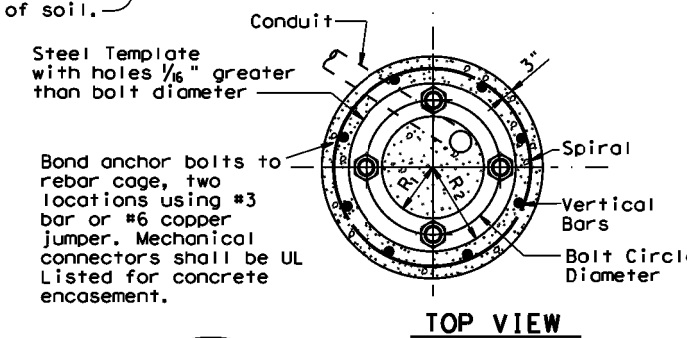

TOP VIEW

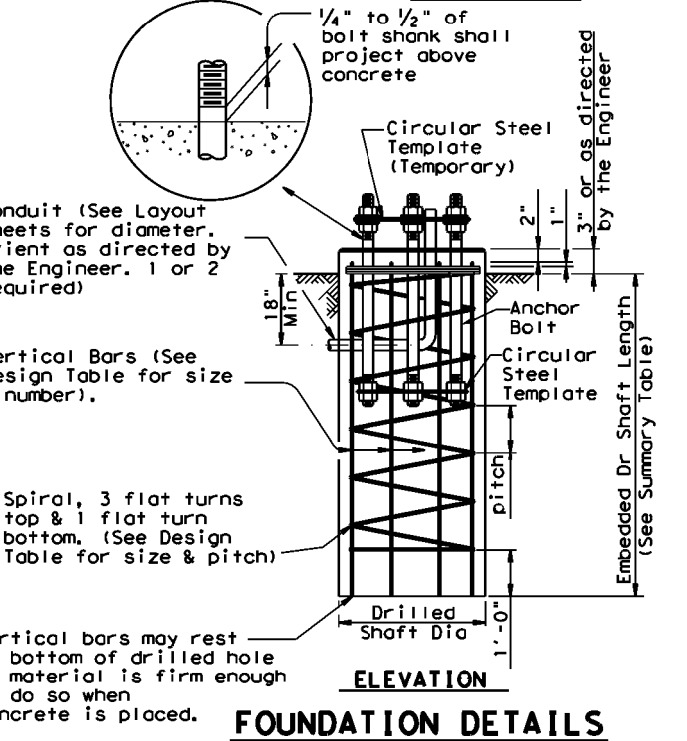

ELEVATION

FOUNDATION DETAILS

FOUNDATION SUMMARY TABLE (3)

LOCATION IDENTIFICATION	AVG. N BLOW /ft.	FDN TYPE	NO. EA	DRILLED SHAFT LENGTH (6) (FEET)				
				24-A	30-A	36-A	36-B	42-A
P-1	10	24-A	1	6				
P-2	10	24-A	1	6				
T-2	10	36-A	1			13		
P-3	10	24-A	1	6				
P-4	10	24-A	1	6				
P-5	10	24-A	1	6				
P-6	10	24-A	1	6				
T-4	10	36-A	1			13		
P-7	10	24-A	1	6				
P-8	10	24-A	1	6				
P-9	10	24-A	1	6				
P-10	10	24-A	1	6				
P-11								SEE RID(2)-20 FOR ILLUMINATION FOUNDATION DETAIL
TOTAL DRILLED SHAFT LENGTHS				60*		26		

* PED POLE FOUNDATION IS SUBSIDIARY TO ITEM 687.

GENERAL NOTES:

- Design conforms to 1994 AASHTO Standard Specifications for Structural Supports for Highway Signs, Luminaires and Traffic Signals and interim revisions thereto.
- Reinforcing steel shall conform to Item 440, "Reinforcing Steel".
- Concrete shall be Class "C".
- Threads for anchor bolts and nuts shall be rolled or cut threads of BUN series up to 2" in diameter or UNC series for all sizes. Bolts and nuts shall have Class 2A and 2B fit tolerances. Galvanized nuts shall be tapped after galvanizing.
- Anchor bolts that are larger than 1" in diameter shall conform to "alloy steel" or "medium-strength mild steel" per Item 449, "Anchor Bolts". Anchor bolts that are 1" in diameter or less shall conform to ASTM A36. Galvanize a minimum of the top end thread length plus 6" for all anchor bolts unless otherwise noted. Exposed washers and exposed nuts shall be galvanized. All galvanizing shall be in accordance with Item 445, "Galvanizing".
- Templates and embedded nuts need not be galvanized. Lubricate and tighten anchor bolts when erecting the structure in accordance with Item 449, "Anchor Bolts".



TRAFFIC SIGNAL POLE FOUNDATION TS-FD-12

---NOT FOR CONSTRUCTION---
 THIS DOCUMENT HAS BEEN RELEASED FOR THE PURPOSE OF INTERIM REVIEW UNDER THE AUTHORITY OF ZEGEYE Z. KEBEDE, P.E. 121726
 IT IS NOT TO BE USED FOR CONSTRUCTION PURPOSES.
 05/05/2021
 ---NOT FOR CONSTRUCTION---

© TxDOT August 1995		DN: MS	CK: JSY	DN: MAO/AMF	CK: JSY/TEB
5-96	REVISIONS	CONT	SECT	JOB	HIGHWAY
11-92		DIST	COUNTY		SHEET NO.
					101

DISCLAIMER: The use of this standard is governed by the "Texas Engineering Practice Act". No warranty of any kind is made by TxDOT for any purpose whatsoever. TxDOT assumes no responsibility for the conversion of this standard to other formats or for incorrect results or damages resulting from its use.

DATE: FILE:

GENERAL NOTES FOR ALL ELECTRICAL WORK

- The location of all conduits, junction boxes, ground boxes, and electrical services is diagrammatic and may be shifted to accommodate field conditions.
- Provide new and unused materials. Ensure that all materials and installations comply with the applicable articles of the National Electrical Code (NEC), TxDOT standards and specifications, National Electrical Manufacturers Association (NEMA), and are listed by Underwriters Laboratories (UL) or a Nationally Recognized Testing Lab (NRTL). NRTLs such as Canadian Standard Association (CSA), Intertek Testing Services NA Inc., or FM Approvals LLC can be considered equivalent to UL. Where reference is made to NEMA listed devices, International Electrotechnical Commission (IEC) listed devices will not be considered an acceptable equal to a NEMA listed device. Acceptable devices may have both a NEMA and IEC listing. Faulty fabrication or poor workmanship in any material, equipment, or installation is justification for rejection. Replace or reinstall rejected material or equipment at no additional cost to the Department.
- Miscellaneous nuts, bolts and hardware, except for high strength bolts, may be stainless steel when plans specify galvanized, provided the bolt size is 1/2 in. or less in diameter.
- Provide the following test equipment as required by the Engineer to confirm compliance with the contract and the NEC: voltmeter, ammeter, megohm meter (1000 volt DC), ground resistance tester, torque wrenches, and torque screwdrivers. Ensure all equipment has been properly calibrated within the last year. Provide calibration certification to the Engineer upon request. Operate test equipment during inspection as requested by the Engineer.
- Install grounding as shown on the plans and in accordance with the NEC. Ensure all metallic conduits; metal poles; luminaires; and metal enclosures are bonded to the equipment grounding conductor. Provide stranded bare copper or green insulated grounding conductors. Ground rods, connectors, and bonding jumpers are subsidiary to the various bid items.
- When required by the Engineer, notify the Department in writing of materials from the Material Producers List (MPL) intended for use on each project. Prequalified materials are listed on the MPL on TxDOT's website under "Roadway Illumination and Electrical Supplies." No substitutions will be allowed for materials on this list.

CONDUIT

A. MATERIALS

- Provide conduit, junction boxes, fittings, and hardware as per TxDOT Departmental Material Specification (DMS) 11030 "Conduit" and Item 618 "Conduit" of TxDOT's "Standard Specifications For Construction And Maintenance Of Highways, Streets, And Bridges," latest edition. Provide conduits listed under Item 618 on the MPL under "Roadway Illumination and Electrical Supplies." Provide conduit types according to the descriptive code or as shown on the plans. Do not substitute other types of conduits for those shown. Provide liquidtight flexible metal conduit (LFMC) when flexible conduit is called for on galvanized steel rigid metallic conduit (RMC) systems. Provide liquidtight flexible nonmetallic conduit (LFNC) when flexible conduit is called for on polyvinyl chloride (PVC) systems.
- Provide galvanized steel RMC for all exposed conduits, unless otherwise shown on the plans. Properly bond all metal conduits.
- Unless otherwise shown on the plans, provide junction boxes with a minimum size as shown in the following table, which applies to the greatest number of conductors entering the box through one conduit with no more than four conduits per box. When a mixture of conductor sizes is present, count the conductors as if all are of the larger size. For situations not applicable to the table, size junction boxes in accordance with NEC.

AWG	3 CONDUCTORS	5 CONDUCTORS	7 CONDUCTORS
#1	10" x 10" x 4"	12" x 12" x 4"	16" x 16" x 4"
#2	8" x 8" x 4"	10" x 10" x 4"	12" x 12" x 4"
#4	8" x 8" x 4"	10" x 10" x 4"	10" x 10" x 4"
#6	8" x 8" x 4"	8" x 8" x 4"	10" x 10" x 4"
#8	8" x 8" x 4"	8" x 8" x 4"	8" x 8" x 4"

- Junction boxes with an internal volume of less than 100 cu. in. and supported by entering raceways must have threaded entries or hubs identified for the intended purpose and supported by connection of two or more rigid metal conduits. Secure conduit within 3 ft. of the enclosure or within 18 in. of the enclosure if all conduit entries are on the same side. Mechanically secure all junction boxes with an internal volume greater than 100 cu. inches.
- Provide hot dipped galvanized cast iron or sand cast aluminum outlet boxes for junction boxes containing only 10 AWG or 12 AWG conductors. Do not use die cast aluminum boxes. Size outlet boxes according to the NEC.
- Do not use intermediate metal conduit (IMC) or electrical metallic tubing (EMT) unless specifically required by the plan sheets. When EMT is called for, provide junction boxes made from galvanized steel sheeting, listed and approved for outdoor use, unless otherwise noted on the plans. Size all galvanized steel junction boxes in accordance with the NEC. Provide junction boxes for IMC conduit systems that meet the same requirements for junction boxes used with RMC systems.
- Provide PVC junction boxes intended for outdoor use on PVC conduit systems, unless otherwise noted on the plans.

- Provide PVC elbows in PVC conduit systems, unless otherwise shown on the plans. Use only a flat, high tensile strength polyester fiber pull tape for pulling conductors through the PVC conduit system. When galvanized steel RMC elbows are specifically called for in the plans and any portion of the RMC elbow is buried less than 18 in., ground the RMC elbow by means of a grounding bushing on a rigid metal extension. Grounding of the rigid metal elbow is not required if the entire RMC elbow is encased in a minimum of 2 in. of concrete. PVC extensions are allowed on these concrete encased rigid metal elbows. RMC or PVC elbows are subsidiary to various bid items.
- When required, provide High-Density Polyethylene (HDPE) conduit with factory installed internal conductors according to Item 622 "Duct Cable." At the Contractor's request and with approval by the Engineer, substitute HDPE conduit with no conductors for bored schedule 40 or schedule 80 PVC conduit bid under Item 618. Ensure bored HDPE substituted for PVC is schedule 40 and of the same size PVC called for in the plans. Ensure the substituted HDPE meets the requirements of Item 622, except that the conduit is supplied without factory-installed conductors. Make the transition of the HDPE conduit to PVC (or RMC elbow when required) at the bore pit. Provide conduit of the size and schedule as shown on the plans. Do not extend substituted conduit into ground boxes or foundations. Provide PVC or galvanized steel RMC elbows as called for at all ground boxes and foundations.
- Use two-hole straps when supporting 2 in. and larger conduits. On electrical service poles, properly sized stainless steel or hot dipped galvanized one-hole standoff straps are allowed on the service riser conduit.

B. CONSTRUCTION METHODS

- Provide and install expansion joint conduit fittings on all structure-mounted conduits at the structure's expansion joints to allow for movement of the conduit. In addition, provide and install expansion joint fittings on all continuous runs of galvanized steel RMC conduit externally exposed on structures such as bridges at maximum intervals of 150 ft. When requested by the project Engineer, supply manufacturer's specification sheet for expansion joint conduit fittings. Repair or replace expansion joint fittings that do not allow for movement at no additional cost to the Department. Provide the method of determining the amount of expansion to the Engineer upon request. Do not use LFMC or LFNC as a substitute for the required expansion conduit fittings.
- Space all conduit supports at maximum intervals of 5 ft. Install conduit spacers when attaching metal conduit to surface of concrete structures. See "Conduit Mounting Options" on ED(2). Install conduit support within 3 ft. of all enclosures and conduit terminations.
- Do not attach conduit supports directly to pre-stressed concrete beams except as shown specifically in the plans or as approved by the Engineer.
- Unless otherwise shown on the plans, jack or bore conduit placed beneath existing roadways, driveways, sidewalks, or after the base or surfacing operation has begun. Backfill and compact the bore pits below the conduit per Item 476 "Jacking, Boring, or Tunneling Pipe or Box" prior to installing conduit or duct cable to prevent bending of the connections.
- When placing conduit in the sub-grade of new roadways, backfill all trenches with excavated material unless otherwise noted on the plans. When placing conduit in the sub-base of new roadways, backfill all trenches with cement-stabilized base as per requirements of Items 110 "Excavation", 400 "Excavation and Backfill for Structures", 401 "Flowable Backfill", 402 "Trench Excavation Protection", and 403 "Temporary Special Shoring."
- Provide and place warning tape approximately 10 in. above all trenched conduit as per Item 618.
- During construction, temporarily cap or plug open ends of all conduit and raceways immediately after installation to prevent entry of dirt, debris and animals. Temporary caps constructed of durable duct tape are allowed. Tightly fix the tape to the conduit opening. Clean out the conduit and prove it clear in accordance with Item 618 prior to installing any conductors.
- Ensure conduit entry into the top of any enclosure is waterproof by installing conduit sealing hubs or using boxes with threaded bosses. This includes surface mounted safety switches, meter cans, service enclosures, auxiliary enclosures and junction boxes. Grounding bushings on water tight sealing hubs are not required.
- Fit the ends of all PVC conduit terminations with bushings or bell end fittings. Provide and install a grounding type bushing on all metal conduit terminations.
- Install a bonding jumper from each grounding bushing to the nearest ground rod, grounding lug, or equipment grounding conductor. Ensure all bonding jumpers are the same size as the equipment grounding conductor. Bonding of conduit used as a casing under roadways for duct cable is not required, if the duct extends the full length through the casing.
- At all electrical services, install a 6 AWG solid copper grounding electrode conductor.
- Place conduits entering ground boxes so that the conduit openings are between 3 in. and 6 in. from the bottom of the box. See the ground box detail on sheet ED(4).
- Seal ends of all conduits with duct seal, expandable foam, or by other methods approved by the Engineer. Seal conduit immediately after completion of conductor installation and pull tests. Do not use duct tape as a permanent conduit sealant. Do not use silicone caulk as a conduit sealant.
- File smooth the cut ends of all mounting strut and conduit. Before installing, paint the field cut ends of all mounting strut and RMC (threaded or non-threaded) with zinc rich paint (94% or more zinc content) to alleviate overspray. Use zinc rich paint to touch up galvanized material as allowed under Item 445 "Galvanizing." Do not paint non-galvanized material with a zinc rich paint as an alternative for materials required to be galvanized.

 Texas Department of Transportation		Traffic Operations Division Standard	
<h1>ELECTRICAL DETAILS CONDUITS & NOTES</h1>			
<h2>ED(1) - 14</h2>			
FILE:	ed1-14.dgn	DW:	CK:
© TxDOT	October 2014	CONT	SECT
REVISIONS		JOB	
		HIGHWAY	
		COUNTY	
		SHEET NO.	
		102	

ELECTRICAL CONDUCTORS

A. MATERIAL INFORMATION

1. Provide Type XHHW insulated conductors in accordance with Departmental Material Specification (DMS) 11040 "Conductors" and Item 620 "Electrical Conductors." Provide conductors as listed on the Material Producers List (MPL) on the Department web site under "Roadway Illumination and Electrical Supplies" Item 620. Color code insulated conductors in conformance with the NEC. Identify grounded (neutral) conductors with white insulation. Identify grounding conductors (ground wires) with green insulation or bare conductors. Identify ungrounded (hot) conductors with any color insulation except green, white, or gray. Keep color scheme consistent throughout the wiring system. Identify conductors 6 American Wire Gauge (AWG) and smaller by continuous color jacket. Identify electrical conductors 4 AWG and larger by continuous color jacket or by colored tape. When identifying conductors with colored tape, mark at least 6 in. of the conductor's insulation with half laps of tape.
2. Provide a solid copper 6 AWG grounding electrode conductor to bond the electrical service equipment to the concrete encased grounding electrode or the ground rod at the service location. Connect the grounding electrode conductor to the ground rod with a UL listed connector in accordance with DMS 11040. Connect the grounding electrode conductor to the concrete encased grounding electrode as shown in the plans.
3. Where two or more circuits are present in one conduit or enclosure, permanently identify the conductors of each branch circuit by attaching a non-metallic tag around both circuit conductors at each accessible location. Provide tags with two straps, large enough to indicate circuit number, letter, or other identification as shown in the plans. Print circuit identification on the tag with a permanent marker.
4. Use listed compression or screw type pressure connectors, terminal blocks, or split bolt connectors for splicing as specified in DMS 11040. Use hot melt adhesive tape to fill the gap and seal the ends of heat shrink tubing. Provide UL listed gel-filled insulating splice covers. Splicing materials, insulating materials, breakaway disconnects, splice covers, and fuse holders are subsidiary to various bid items.

B. CONSTRUCTION METHODS

1. Use only a flat, high tensile strength polyester fiber pull tape for pulling conductors through the conduit system. After installing conductors in conduit, perform conductor pull test. If a conductor cannot be freely pulled, make any needed alterations or repairs at no additional cost to the department. Perform insulation resistance tests in accordance with Item 620. Coordinate with the Engineer to witness the tests.
2. Leave 2 ft. minimum, 3 ft. maximum length for each conductor up to the splice in ground boxes. Leave 3 ft. minimum, 4 ft. maximum length of conductor in ground boxes when pulled through with no splice. Leave 1 ft. minimum, 1.5 ft. maximum length of conductor at enclosures, weatherheads and pole bases.
3. Make splices only in junction boxes, ground boxes, pole bases, or electrical enclosures and use only listed compression or screw type pressure connectors, terminal blocks, or split bolt connectors. Insulate splices with heavy wall heat shrink tubing or gel-filled insulating splice covers to provide a watertight splice. Overlap conductor insulation with heat shrink tubing a minimum of 2 in. past both sides of the splice. Where heat shrink tubing may not shrink sufficiently to provide a watertight seal around the individual conductors, prior to heating the tubing, increase the diameter of the conductor insulation using hot melt adhesive tape to provide a watertight seal between the individual conductors and the heat shrink tubing. Ensure the tape extends past the heat shrink tubing. Use hot melt adhesive tape to fill the gap and seal the ends of heat shrink tubing. Heat shrink tubing that appears to have been burned, or overheated, is considered defective and must be replaced.
4. Size and install gel-filled insulating splice covers according to manufacturer's specifications when used in place of heat shrink tubing.
5. Wire nuts with factory applied waterproof sealant may be used for 8 AWG or smaller conductors in above ground junction boxes, but not in pole bases or ground boxes. Install wire nuts in an upright position to prevent the accumulation of water.
6. Support conductors in illumination poles with a J-hook at the top of the pole.
7. When terminating conductors, remove the insulation and jacketing material without nicking the individual strands of the conductor. Conductors with nicked individual conductor strands or removed strands will be considered damaged.
8. Replace conductors and cables that are damaged beyond repair or that fail an insulation resistance test at no additional cost to the department.
9. Do not repair damaged conductors with duct tape, electrical tape, or wire nuts. Use only approved splicing methods.
10. Do not terminate more than one conductor under a single connector, unless the connector is rated for multiple conductors. Do not exceed the pressure connector's listing for maximum number and size of conductors allowed.
11. Install breakaway connectors on conductors bid under Item 620 whenever those conductors pass through a breakaway support device. Follow manufacturer's instructions when terminating conductors to breakaway connectors. Properly torque threaded connections. Proper terminations are critical to the safe operation of breakaway devices. Trim waterproofing boots on breakaway connectors to fit snugly around the conductor to ensure waterproof connection. Only one conductor may enter a single opening in a boot. Provide waterproof boots with the correct number of openings. Leave unused openings factory sealed. Use prequalified breakaway connectors as shown on the MPL.

DISCLAIMER: The use of this standard is governed by the "Texas Engineering Practice Act". No warranty of any kind is made by TxDOT for any purpose whatsoever. TxDOT assumes no responsibility for the conversion of this standard to other formats or for incorrect results or damages resulting from its use.

12. Provide and install a separate stranded equipment grounding conductor (EGC) in all conduits that contain circuit wiring of 50 volts or more. Unless shown elsewhere, size the EGC to be the same size as the largest current carrying conductor contained in the conduit. Ensure all EGCs are bonded together at every accessible location. For traffic signal installations, provide a minimum size 8 AWG EGC. The EGC is paid for under Item 620.

C. TEMPORARY WIRING

1. Install temporary conductors and electrical equipment in accordance with the NEC article "Temporary Installations" and Department standard sheets.
2. Provide a ground fault circuit interrupter (GFCI) for power outlets for portable electrical equipment, power tools, ice machines, ice storage bins and refrigerators located outdoors at grade. GFCI may be any one of the following: molded cord and plug set, receptacle, or circuit breaker type.
3. Use listed wire nuts with factory applied sealant for temporary wiring where approved.
4. Enclose conductor splices within a listed enclosure or ground box, or ensure the splices are more than 10 ft. above grade vertically and more than 5 ft. horizontally from any metal structure. Where installing temporary conductors in areas subject to vehicle traffic or mobile construction equipment, ensure the vertical clearance to ground is at least 18 ft. when measured at the lowest point. Ground messenger wires that support power conductors in conformance with the NEC.
5. Protect and when necessary repair any existing electrical conduits uncovered during the construction process in a timely manner and in conformance with the NEC.

GROUND RODS & GROUNDING ELECTRODES

A. MATERIAL INFORMATION

1. Provide and install a grounding electrode at electrical services. Provide ground rods according to DMS 11040 and the plans. Larger diameter or longer length rods may be called for in some specific locations, see the individual plans sheets. Concrete encased grounding electrodes may be called for in specific locations including electrical service, see individual plan sheets.

B. CONSTRUCTION METHODS

1. Furnish auxiliary ground rods for lightning protection and install in soil, concrete, or both, as called for in the plans. For ground rods installed in concrete, ensure the connection of the conductor to the ground rod is readily accessible for inspection or repairs. For ground rods installed in soil, ensure that the upper end is between 2 to 4 in. below finished grade.
2. Do not place ground rods in the same drilled hole as a timber pole.
3. Install ground rods so the imprinted part number is at the upper end of the rod.
4. Remove all non-conductive coatings such as concrete splatter from the rod at the clamp location.
5. Route all conductors as short and straight as possible for connection to lightning protection ground rods. When a bend is required, ensure a minimum radius bend of four inches for these conductors.
6. Unless otherwise called for in the plans, protect grounding electrode conductors with non-metallic conduit. When protecting grounding electrode conductors with metal conduit, provide and install a grounding type bushing and properly sized bonding jumper on each end of the metal conduit.
7. Written authorization is required before installing a ground rod in a horizontal trench for rocky soil or a solid rock bottom.

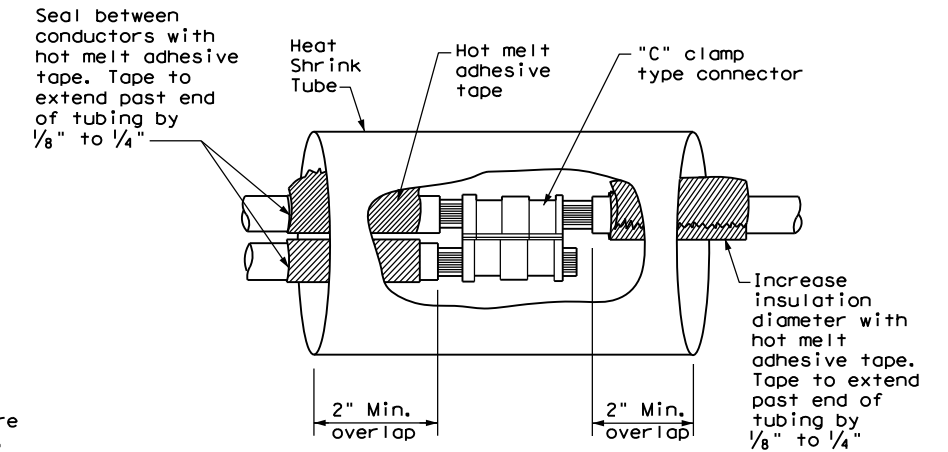

**SPLICE OPTION 1
Compression Type**

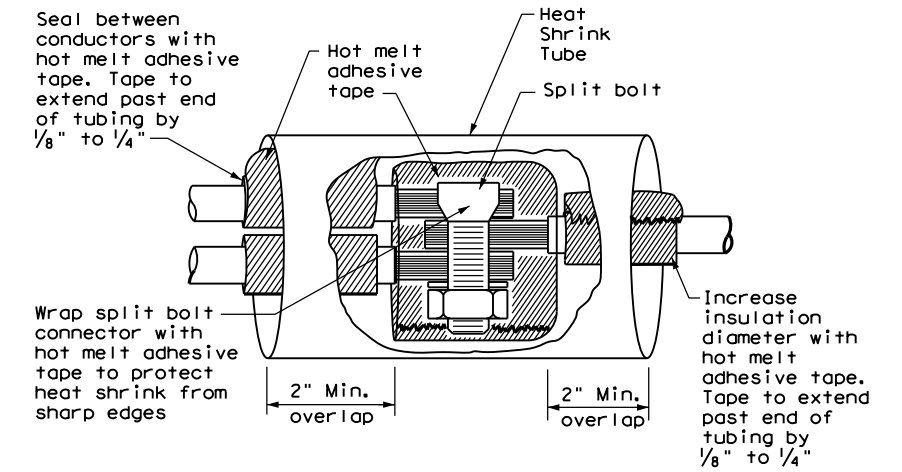

**SPLICE OPTION 2
Split Bolt Type**

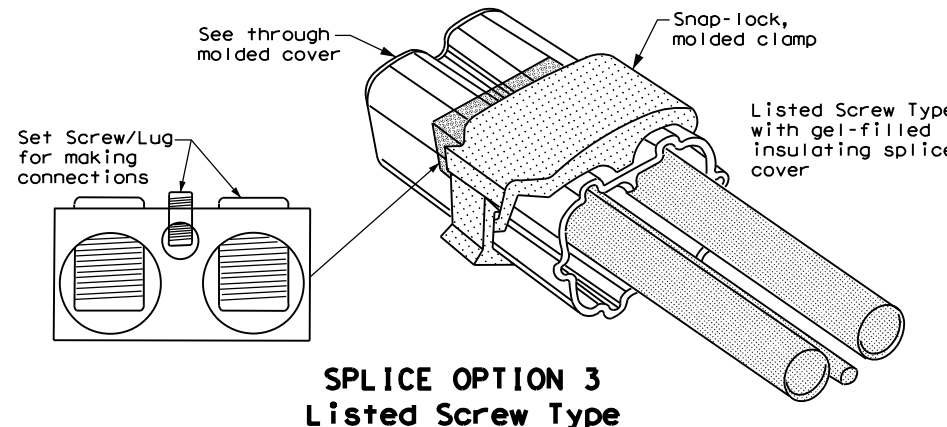

**SPLICE OPTION 3
Listed Screw Type**

		Traffic Operations Division Standard	
<h2>ELECTRICAL DETAILS CONDUCTORS</h2>			
<h3>ED(3) - 14</h3>			
FILE: ed3-14.dgn	DW: TxDOT	CK: TxDOT	CR: TxDOT
© TxDOT October 2014	CONT	SECT	JOB
REVISIONS	DIST		COUNTY
			SHEET NO.
			103

DATE: FILE:

DISCLAIMER: The use of this standard is governed by the "Texas Engineering Practice Act". No warranty of any kind is made by TxDOT for any purpose whatsoever. TxDOT assumes no responsibility for the conversion of this standard to other formats or for incorrect results or damages resulting from its use.

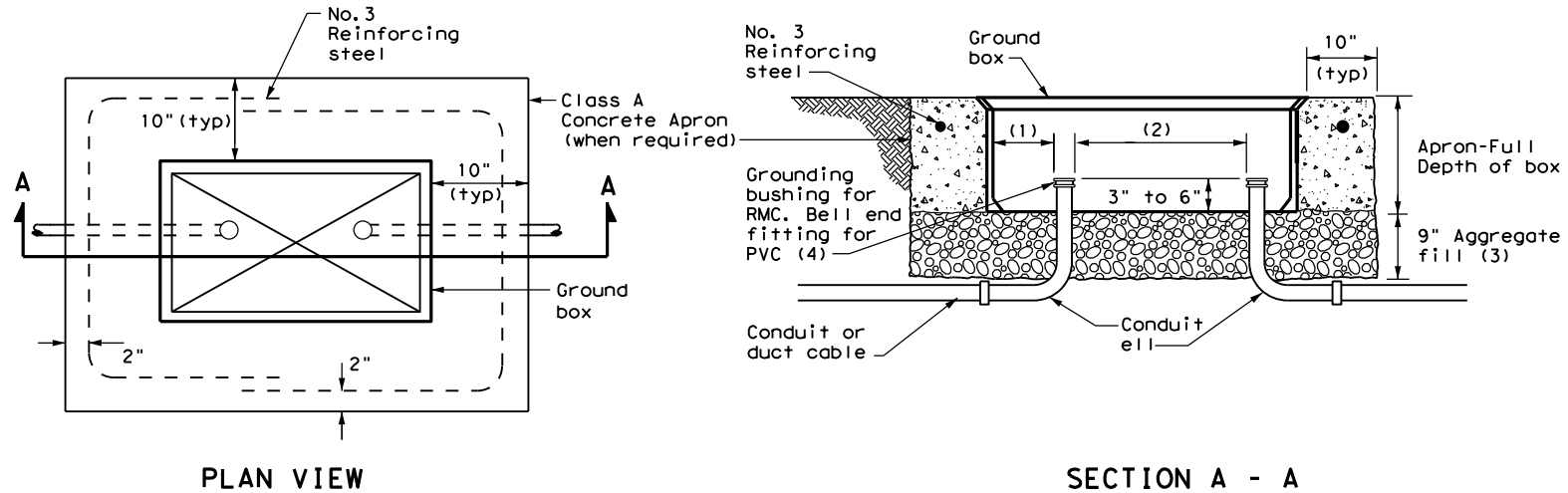

APRON FOR GROUND BOX

- (1) Uniformly space ends of conduits within the ground box. Position ends of conduits so that ground box walls do not interfere with the installation of grounding bushings or bell end fittings.
- (2) Maintain sufficient space between conduits to allow for proper installation of bushing.
- (3) Place aggregate under the box, not in the box. Aggregate should not encroach on the interior volume of the box.
- (4) Install a grounding bushing on the upper end of all RMC terminating in a ground box. Ground RMC elbows when any part of the elbow is less than 18 in. below the bottom of the ground box. Install a PVC bushing or bell end fitting on the upper end of all PVC conduits terminating in a ground box.

GROUND BOX DIMENSIONS

TYPE	OUTSIDE DIMENSIONS (INCHES) (Width x Length X Depth)
A	12 X 23 X 11
B	12 X 23 X 22
C	16 X 29 X 11
D	16 X 29 X 22
E	12 X 23 X 17

GROUND BOX COVER DIMENSIONS

TYPE	DIMENSIONS (INCHES)							
	H	I	J	K	L	M	N	P
A, B & E	23 1/4	23	13 3/4	13 1/2	9 7/8	5 1/8	1 3/8	2
C & D	30 1/2	30 1/4	17 1/2	17 1/4	13 1/4	6 3/4	1 3/8	2

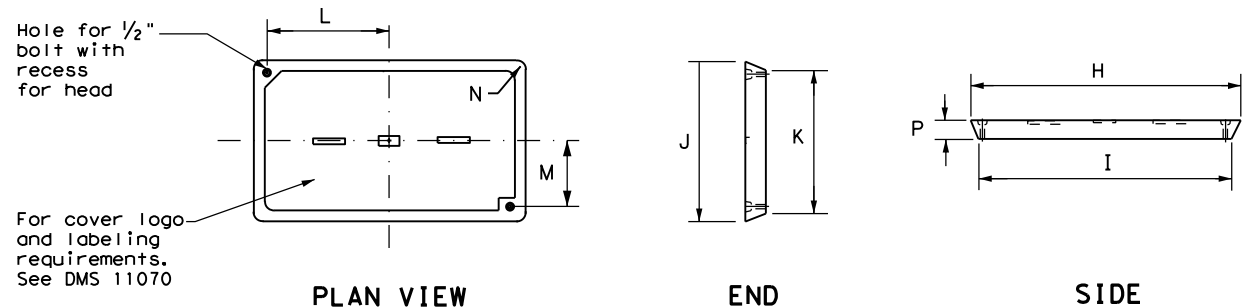

GROUND BOX COVER

GROUND BOXES

A. MATERIALS

1. Provide polymer concrete ground boxes measuring 16x30x24 in. (WxLxD) or smaller in accordance with Departmental Material Specification (DMS) 11070 "Ground Boxes" and Item 624 "Ground Boxes."
2. Provide Type A, B, C, D, and E ground boxes as shown in the plans, and as listed on the Material Producers List (MPL) on the Department web site under "Roadway Illumination and Electrical Supplies," Item 624.

3. Ensure ground box cover is correctly labeled in accordance with DMS 11070.

4. Provide larger ground boxes in accordance with Item 624 and as shown in the plans.

B. CONSTRUCTION METHODS

1. Remove all gravel and dirt from conduit. Cap all conduits prior to placing aggregate and setting ground box. Provide Grade 3 or 4 coarse aggregate as shown on Table 2 of Item 302 "Aggregates for Surface Treatments." Ensure aggregate bed is in place and at least 9 inches deep, prior to setting the ground box. Install ground box on top of aggregate.
2. Cast ground box aprons in place. Reinforcing steel may be field bent. Ensure the depth of concrete for the apron extends from finished grade to the top of the aggregate bed under the box. Ground box aprons, including concrete and reinforcing steel, are subsidiary to ground boxes when called for by descriptive code.
3. Keep bolt holes in the box clear of dirt. Bolt covers down when not working in ground boxes.
4. Install all conduits and ells in a neat and workmanlike manner. Uniformly space conduits so grounding bushings and bell end fittings can easily be installed.
5. Temporarily seal all conduits in the ground box until conductors are installed.
6. Permanently seal conduits immediately after the completion of conductor installation and pull tests. Permanently seal the ends of all conduits with duct seal, expandable foam, or other method as approved. Do not use duct tape as a permanent conduit sealant. Do not use silicone caulk as a sealant.
7. When a ground rod is present in a ground box, bond all equipment grounding conductors together and to the ground rod with listed connectors.
8. When a type B or D ground box is stacked to meet volume requirements, it is allowable to cut an appropriately sized hole for conduit entry in the side wall at least 18 inches below grade.
9. If an existing ground box in the contract has a metal cover, bond the cover to the equipment grounding conductor with a 3 ft. long stranded bonding jumper the same size as the grounding conductor. The bonding jumper is subsidiary to various bid items. Verify existing ground boxes with metal covers are shown on the plans, with notes fully describing the work required.
10. If other ground boxes with metal covers are within the project limits but are not part of the contract, the Engineer may direct the Contractor to bond the metal covers, identifying the specific boxes in writing. This work will be paid for separately.
11. Bond metal ground box covers to the grounding conductor with a tank ground type lug.

				<i>Traffic Operations Division Standard</i>	
ELECTRICAL DETAILS GROUND BOXES					
ED(4) - 14					
FILE:	ed4-14.dgn	DN:	TxDOT	CK:	TxDOT
© TxDOT	October 2014	CONT:	SECT:	JOB:	HIGHWAY:
REVISIONS		DIST:	COUNTY		SHEET NO.
					104

DATE:
FILE:

ELECTRICAL SERVICES NOTES

1. Provide new materials. Ensure installation and materials comply with the applicable provisions of the National Electrical Code (NEC) and National Electrical Manufacturers Association (NEMA) standards. Ensure material is Underwriters Laboratories (UL) listed. Provide and install electrical service conduits, conductors, disconnects, contactors, circuit breaker panels, and branch circuit breakers as shown on the Electrical Service Data chart in the plans. Faulty fabrication or poor workmanship in material, equipment, or installation is justification for rejection. Where manufacturers provide warranties and guarantees as a customary trade practice, furnish these to the State.
2. Provide electrical services in accordance with Electrical Details standard sheets, Departmental Material Specification (DMS) 11080 "Electrical Services," DMS 11081 "Electrical Services-Type A," DMS 11082 "Electrical Services-Type C," DMS 11083 "Electrical Services-Type D," DMS 11084 "Electrical Services-Type T," DMS 11085 "Electrical Services-Pedestal (PS)", and Item 628 "Electrical Services" of the Standard Specifications. Provide electrical service types A, C, and D, as listed on the Material Producers List (MPL) on the Department web site under "Roadway Illumination and Electrical Supplies," Item 628. Provide other service types as detailed on the plans.
3. Provide all work, materials, services, and any incidentals needed to install a complete electrical service as specified in the plans.
4. Coordinate with the Engineer and the utility provider for metering and compliance with utility requirements. Primary line extensions, connection charges, meter charges, and other charges by the utility company to provide power to the location are paid for in accordance with Item 628. Get approval for the costs associated with these charges prior to engaging the utility company to do the work. Consult with the utility provider to determine costs and requirements, and coordinate the work as approved.
5. The enclosure manufacturer will provide Master Lock Type 2 with brass tumblers keyed #2195 for all custom electrical enclosures. Installing Contractor is to provide Master Lock #2195 Type 2 with brass tumblers for "off the shelf" enclosures. Master Lock #2195 keys and locks become property of the State. Unless otherwise approved, do not energize electrical service equipment until locks are installed.
6. Enclosures with external disconnects that de-energize all equipment inside the enclosure do not need a dead front trim. Protect incoming line terminations from incidental contact as required by the NEC.
7. When galvanized is specified for nuts, screws, bolts or miscellaneous hardware, stainless steel may be used.
8. Provide wiring and electrical components rated for 75°C. Provide red, black, and white colored XHHW service entrance conductors of minimum size 6 American Wire Gauge (AWG). Identify size 6 AWG conductors by continuous color jacket. Identify electrical conductors sized 4 AWG and larger by continuous color jacket or by colored tape. Mark at least 6 inches of the conductor's insulation with half laps of colored tape, when identifying conductors. Ensure each service entrance conductor exits through a separately bushed non-metallic opening in the weatherhead. The lengths of the conductors outside the weatherhead are to be 12 inches minimum, 18 inches maximum, or as required by utility.
9. All electrical service conduit and conductors attached to the electrical service including the riser or the elbow below ground are subsidiary to the electrical service. For an underground utility feed, all service conduit and conductors after the elbow, including service conduit and conductors for the utility pole riser when furnished by the Contractor, will be paid for separately.
10. Provide rigid metal conduit (RMC) for all conduits on service, except for the 1/2 in. PVC conduit containing the electrical service grounding electrode conductor. Size the service entrance conduit as shown in the plans. Ensure conduit for branch circuit entry to enclosure is the same size as that shown on the layout sheets for branch circuit conduit. Extend all rigid metal conduits a minimum of 6 inches underground and then couple to the type and schedule of the conduit shown on the layout for that particular branch circuit. Install a grounding bushing on the RMC where it terminates in the service enclosure.
11. Use of liquidtight flexible metal conduit (LFMC) is allowed between the meter and service enclosure when they are mounted 90 to 180 degrees to each other. Size the LFMC the same size as service entrance conduit. LFMC must not exceed 3 feet in length. Strap LFMC within 1 foot of each end. LFMC less than 12 inches in length need not be strapped. Each end of LFMC must have a grounding bushing or be terminated with a grounding fitting. The LFMC must contain a grounded (neutral) conductor. Ensure any bend in LFMC never exceeds 180 degrees. A pull test is required on all installed conductors, with at least six inches of free conductor movement demonstrated to the satisfaction of the Engineer.
12. Ensure all mounting hardware and installation details of services conform to utility company specifications.
13. For all electrical service enclosures listed under Item 628 on the MPL, the UL 508 enclosure manufacturers will prepare and submit a schematic drawing unique to each service. Before shipment to the job site, place the applicable laminated schematic drawings and the laminated plan sheet showing the electrical service data chart used to build the enclosure in the enclosure's data pocket. The installing contractor will copy and laminate the actual project plan sheets detailing all equipment and branch circuits supplied by that service. The laminated plan sheets are to be placed in the service enclosure's document pocket. Reduce 11 in. x 17 in. plan sheets to 8 1/2 in. x 11 in. before laminating. If the installation differs from the plan sheets, the installing contractor is to redline plan sheets before laminating.
14. When providing an "Off The Shelf" Type D or Type T service, provide laminated plan sheets detailing equipment and branch circuits supplied by that service. Reduce 11 in. x 17 in. plan sheets to 8 1/2 in. x 11 in. before laminating. Deliver these drawings before completion of the work to the Engineer, instead of placing in enclosure that has no door pocket.
15. Do not install conduit in the back wall of a service enclosure where it would penetrate the equipment mounting panel inside the enclosure. Provide grounding bushings on all metal conduits, and terminate bonding jumpers to grounding bus. Grounding bushings are not required when the end of the metal conduit is fitted with a conduit sealing hub or threaded boss, such as a meter base hub.

SERVICE ASSEMBLY ENCLOSURE

1. Provide threaded hub for all conduit entries into the top of enclosure.
2. Type galvanized steel (GS) enclosures may be used for Type C panelboards and for Type D and T services that do not use an enclosure mounted photoceII or lighting contactor. Provide GS enclosures in accordance with DMS 11080, 11082, 11083, and 11084.
3. Provide aluminum (AL) and stainless steel (SS) enclosures for Types A, C, and D in accordance with DMS 11080, 11081, 11082, 11083, and 11084. Do not paint stainless steel.
4. Provide pedestal service (PS) enclosures in accordance with ED(9) and DMS 11080 and 11085. Do not provide GS pedestal services. If GS is shown in the PS descriptive code, provide an AL enclosure.

MAIN DISCONNECT & BRANCH CIRCUIT BREAKERS

1. Field drill flange-mounted remote operator handle if needed, to ensure handle is lockable in both the "On" and "Off" positions.
2. When the utility company provides a transformer larger than 50 KVA, verify that the available fault current is less than the circuit breaker's ampere interrupting capacity (AIC) rating and provide documentation from the electric utility provider to the Engineer.

PHOTOELECTRIC CONTROL

1. Provide photocell as listed on the MPL. Move, adjust, or shield the photocell from stray or ambient night time light to ensure proper operation. Mount photocell facing north when practical. Mount top of pole photocells as shown on Top Mounted Photocell Detail.

* ELECTRICAL SERVICE DATA												
Elec. Service ID	Plan Sheet Number	Electrical Service Description	Service Conduit *xSize	Service Conductors No./Size	Safety Switch Amps	Main Ckt. Bkr. Pole/Amps	Two-Pole Contractor Amps	Panelbd/ Loadcenter Amp Rating	Branch Circuit ID	Branch Ckt. Bkr. Pole/Amps	Branch Circuit Amps	KVA Load
SB 183	289	ELC SRV TY A 240/480 100(SS)AL(E)SF(U)	2"	3/#2	100	2P/100	100	N/A	Lighting NB	2P/40	26	28.1
									Lighting SB	2P/40	25	
									Underpass	1P/20	15	
NB Access	30	ELC SRV TY D 120/240 060(NS)SS(E)TS(O)	1 1/4"	3/#6	N/A	2P/60		100	Sig. Controller	1P/30	23	5.3
							30		Luminaires	2P/20	9	
									CCTV	1P/20	3	
2nd & Main	58	ELC SRV TY T 120/240 000(NS)GS(N)SP(O)	1 1/4"	3/#6	N/A	N/A	N/A	70	Flashing Beacon 1	1P/20	4	1.0
									Flashing Beacon 2	1P/20	4	

* Example only, not for construction. All new electrical services must have electrical service data chart specific to that service as shown in the plans.
 ** Verify service conduit size with utility. Size may change due to utility meter requirements. Ensure conduit size meets the National Electrical Code.

EXPLANATION OF ELECTRICAL SERVICE DESCRIPTIVE CODE

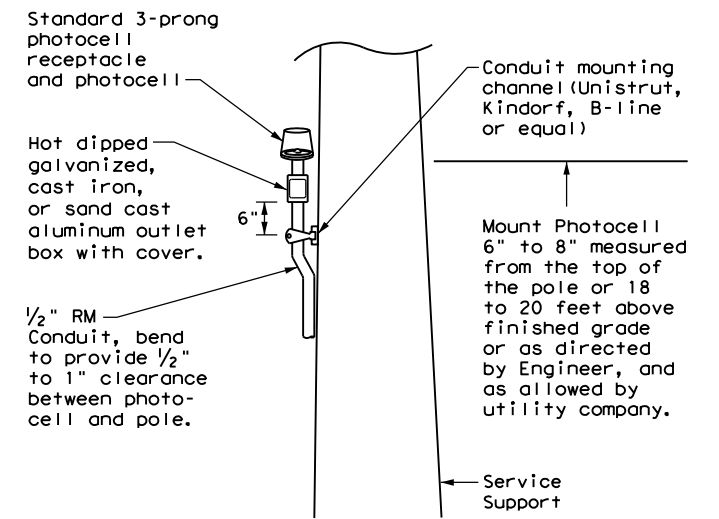
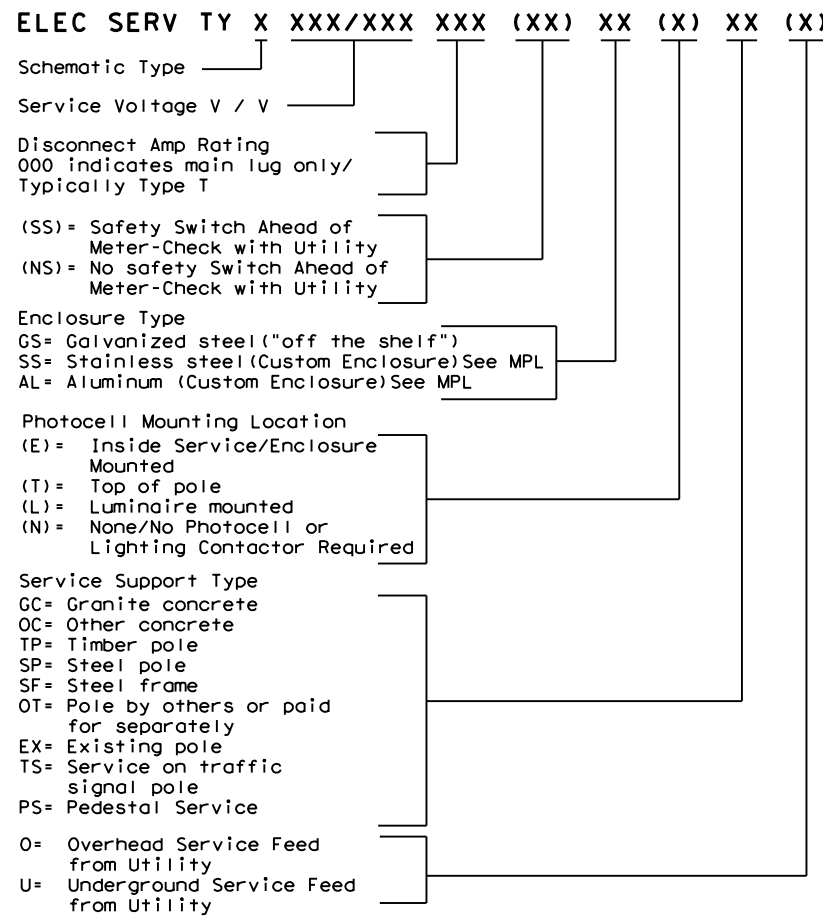

TOP MOUNTED PHOTOCELL

Install conduit strap maximum 3 feet from box. 5 foot maximum spacing between straps supporting conduit.

Texas Department of Transportation Traffic Operations Division Standard

ELECTRICAL DETAILS SERVICE NOTES & DATA

ED(5) - 14

FILE: ed5-14.dgn	DW: TxDOT	CK: TxDOT	DW: TxDOT	CK: TxDOT
© TxDOT October 2014	CONT	SECT	JOB	HIGHWAY
REVISIONS				
DIST	COUNTY			SHEET NO.

105

DISCLAIMER: The use of this standard is governed by the "Texas Engineering Practice Act". No warranty of any kind is made by TxDOT for any purpose whatsoever. TxDOT assumes no responsibility for the conversion of this standard to other formats or for incorrect results or damages resulting from its use.
 DATE: FILE: