

LEGEND

	PROPOSED 6" CONC. DRIVEWAY/ CURB & GUTTER
	PROPOSED 4" SETBACK SIDEWALK (5' WIDE)
	PROPOSED 4" SIDEWALK ADJACENT TO BACK OF CURB (6' WIDE)
	PROPOSED HMAc
	PROPOSED BLOCK SOD

NOTE:
TRENCH DRAINS TO BE CONSTRUCTED OF NEENAH FOUNDRY R-4990-CX WITH TYPE P LIDS AND TYPE M TRENCH FRAME R-4996, OR APPROVED SIMILAR.

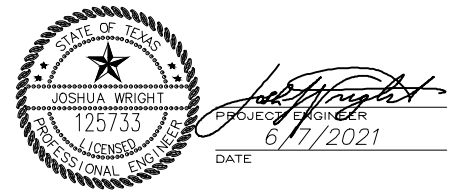
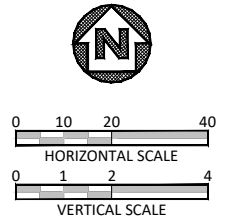

- NOTES:**
- VERTICAL PROFILES PROVIDED FOR GENERAL REFERENCE. CONTRACTOR SHALL LAY VERTICAL GRADE PER THESE PLANS AND AS NECESSARY DUE TO VARYING SITE CONDITIONS AT THE DIRECTION OF THE ENGINEER.
 - NEW SIDEWALK AND RAMPS TO ADHERE TO ALL APPLICABLE ADA, TAS, AND PROWAG REGULATIONS.
 - EXISTING DRIVEWAYS TO REMAIN HAVE 2% OR LESS CROSS SLOPE 48" WIDE OR GREATER AT SIDEWALK CROSSING LOCATION. PROPOSED SIDEWALK TO MEET AND MATCH EXISTING PAVEMENT AT THESE DRIVES.
 - EXISTING METERS & VALVES WITHIN LIMITS OF FINISHED GRADE TO BE ADJUSTED VERTICALLY TO MATCH. METERS & VALVES SHALL NOT BE PARTIALLY LOCATED IN DRIVEWAYS OR SIDEWALKS. A 6" CONCRETE APRON TO BE CONSTRUCTED AROUND THESE STRUCTURES. REFER TO DETAIL, SHEET 17.
 - CONTRACTOR SHALL CONFIRM LOCATION OF ALL EXISTING UTILITIES AND ELEVATIONS PRIOR TO CONSTRUCTION.

DATE	BY	REV	REVISION

DUNAWAY 550 Bailey Avenue
Suite 400 Fort Worth, TX 76107
(TX REG #1114) 817-335-1121

FORT WORTH

PROJ NO. 101264 FILE NO. K-2630

Texas Department of Transportation
© 2021

2018 SAFE ROUTES TO SCHOOL IMPROVEMENTS

**DEWEY ST AT SCHWARTZ AVE
BULBOUT LAYOUT**

DIAMOND HILL ELEMENTARY SCHOOL

FED. RD. DIV. NO.	STATE	PROJECT NO.	HIGHWAY NO.
6	TEXAS	STP 2021(929)TP	VA
STATE DISTRICT	COUNTY	CONTROL NO.	SECTION NO.
FTW	TARRANT	0902	90
			JOB NO.
			082
			SHEET NO.
			252

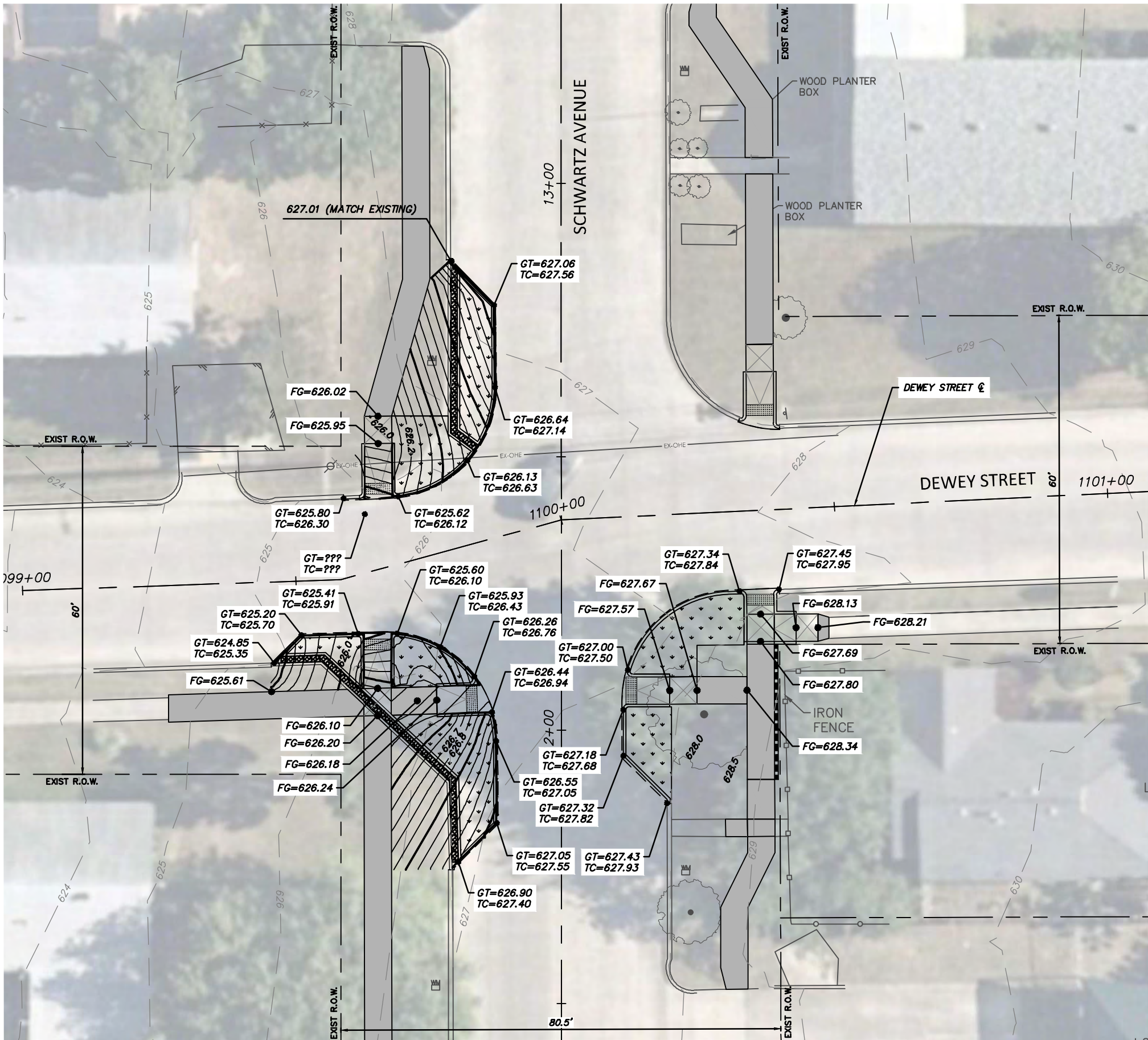

GRADING LEGEND	
--- 600 ---	EXISTING MAJOR CONTOUR (5 FT)
---	EXISTING MINOR CONTOUR (1 FT)
— 600 —	PROPOSED MAJOR CONTOUR (0.5 FT)
---	PROPOSED MINOR CONTOUR (0.1 FT)
====	EXISTING STORM DRAIN
----	FUTURE STORM DRAIN
====	PROPOSED STORM
→	STORMWATER FLOW DIRECTION
—	CHANNEL FLOWLINE
- - - -	TOP OF CUT/TOE OF SLOPE
4:1	PROPOSED GRADE SLOPES

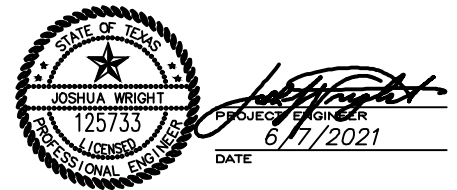
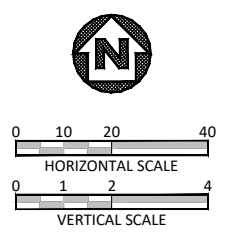

- NOTES:
- VERTICAL PROFILES PROVIDED FOR GENERAL REFERENCE. CONTRACTOR SHALL LAY VERTICAL GRADE PER THESE PLANS AND AS NECESSARY DUE TO VARYING SITE CONDITIONS AT THE DIRECTION OF THE ENGINEER.
 - NEW SIDEWALK AND RAMPS TO ADHERE TO ALL APPLICABLE ADA, TAS, AND PROWAG REGULATIONS.
 - EXISTING DRIVEWAYS TO REMAIN HAVE 2% OR LESS CROSS SLOPE 48" WIDE OR GREATER AT SIDEWALK CROSSING LOCATION. PROPOSED SIDEWALK TO MEET AND MATCH EXISTING PAVEMENT AT THESE DRIVES.
 - EXISTING METERS & VALVES WITHIN LIMITS OF FINISHED GRADE TO BE ADJUSTED VERTICALLY TO MATCH. METERS & VALVES SHALL NOT BE PARTIALLY LOCATED IN DRIVEWAYS OR SIDEWALKS. A 6" CONCRETE APRON TO BE CONSTRUCTED AROUND THESE STRUCTURES. REFER TO DETAIL, SHEET 17.
 - CONTRACTOR SHALL CONFIRM LOCATION OF ALL EXISTING UTILITIES AND ELEVATIONS PRIOR TO CONSTRUCTION.

DATE	BY	REV	REVISION

550 Bailey Avenue
 Suite 400
 Fort Worth, TX 76107
 817-335-1121
 (TX REG #1114)





PROJ NO. 101264 FILE NO. K-2630
 Texas Department of Transportation
 © 2021

2018 SAFE ROUTES TO SCHOOL IMPROVEMENTS

**DEWEY ST AT SCHWARTZ AVE
 BULBOUT GRADING PLAN**
DIAMOND HILL ELEMENTARY SCHOOL

FED. RD. DIV. NO.	STATE	PROJECT NO.	HIGHWAY NO.		
6	TEXAS	STP 2021(929)TP	VA		
STATE DISTRICT	COUNTY	CONTROL NO.	SECTION NO.	JOB NO.	SHEET NO.
FTW	TARRANT	0902	90	082	253

LEGEND

-  PROPOSED 6" CONC. DRIVEWAY/
CURB & GUTTER
-  PROPOSED 4" SETBACK SIDEWALK (5' WIDE)
-  PROPOSED 4" SIDEWALK ADJACENT TO BACK
OF CURB (6' WIDE)
-  PROPOSED HMAc
-  PROPOSED BLOCK SOD

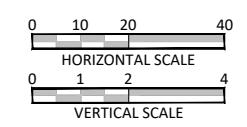
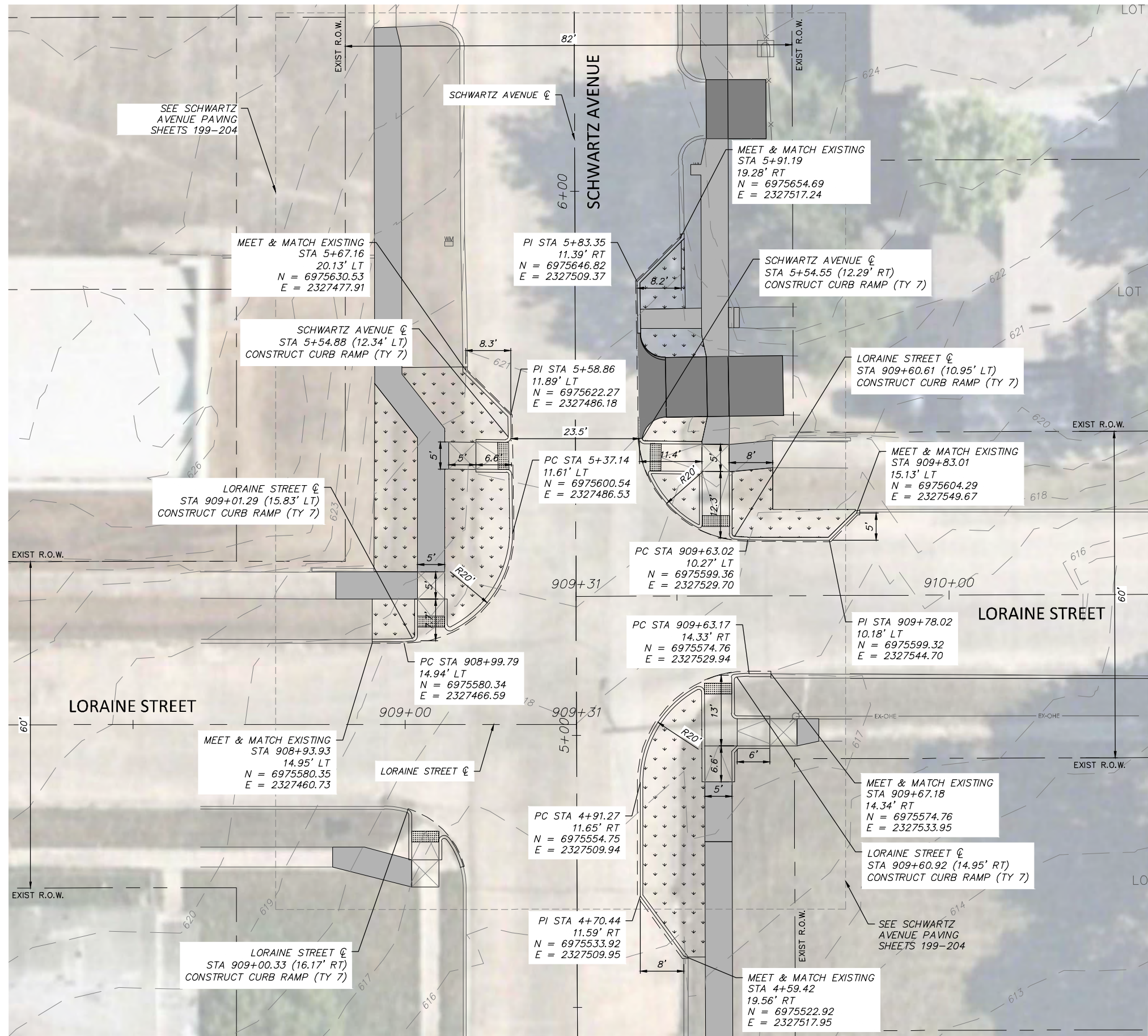

- NOTES:**
1. VERTICAL PROFILES PROVIDED FOR GENERAL REFERENCE. CONTRACTOR SHALL LAY VERTICAL GRADE PER THESE PLANS AND AS NECESSARY DUE TO VARYING SITE CONDITIONS AT THE DIRECTION OF THE ENGINEER.
 2. NEW SIDEWALK AND RAMPS TO ADHERE TO ALL APPLICABLE ADA, TAS, AND PROWAG REGULATIONS.
 3. EXISTING DRIVEWAYS TO REMAIN HAVE 2% OR LESS CROSS SLOPE 48" WIDE OR GREATER AT SIDEWALK CROSSING LOCATION. PROPOSED SIDEWALK TO MEET AND MATCH EXISTING PAVEMENT AT THESE DRIVES.
 4. EXISTING METERS & VALVES WITHIN LIMITS OF FINISHED GRADE TO BE ADJUSTED VERTICALLY TO MATCH. METERS & VALVES SHALL NOT BE PARTIALLY LOCATED IN DRIVEWAYS OR SIDEWALKS. A 6" CONCRETE APRON TO BE CONSTRUCTED AROUND THESE STRUCTURES. REFER TO DETAIL, SHEET 17.
 5. CONTRACTOR SHALL CONFIRM LOCATION OF ALL EXISTING UTILITIES AND ELEVATIONS PRIOR TO CONSTRUCTION.

DATE	BY	REV	REVISION



550 Bailey Avenue
Suite 400
Fort Worth, TX 76107
817-335-1121



PROJ NO. 101264

FILE NO. K-2630

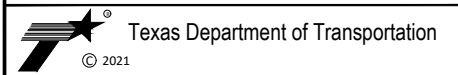

2018 SAFE ROUTES TO SCHOOL IMPROVEMENTS

**LORAIN ST AT SCHWARTZ AVE
BULBOUT LAYOUT**

DIAMOND HILL ELEMENTARY SCHOOL

FED. RD. DIV. NO.	STATE	PROJECT NO.	HIGHWAY NO.		
6	TEXAS	STP 2021(929)TP	VA		
STATE DISTRICT	COUNTY	CONTROL NO.	SECTION NO.	JOB NO.	SHEET NO.
FTW	TARRANT	0902	90	082	254

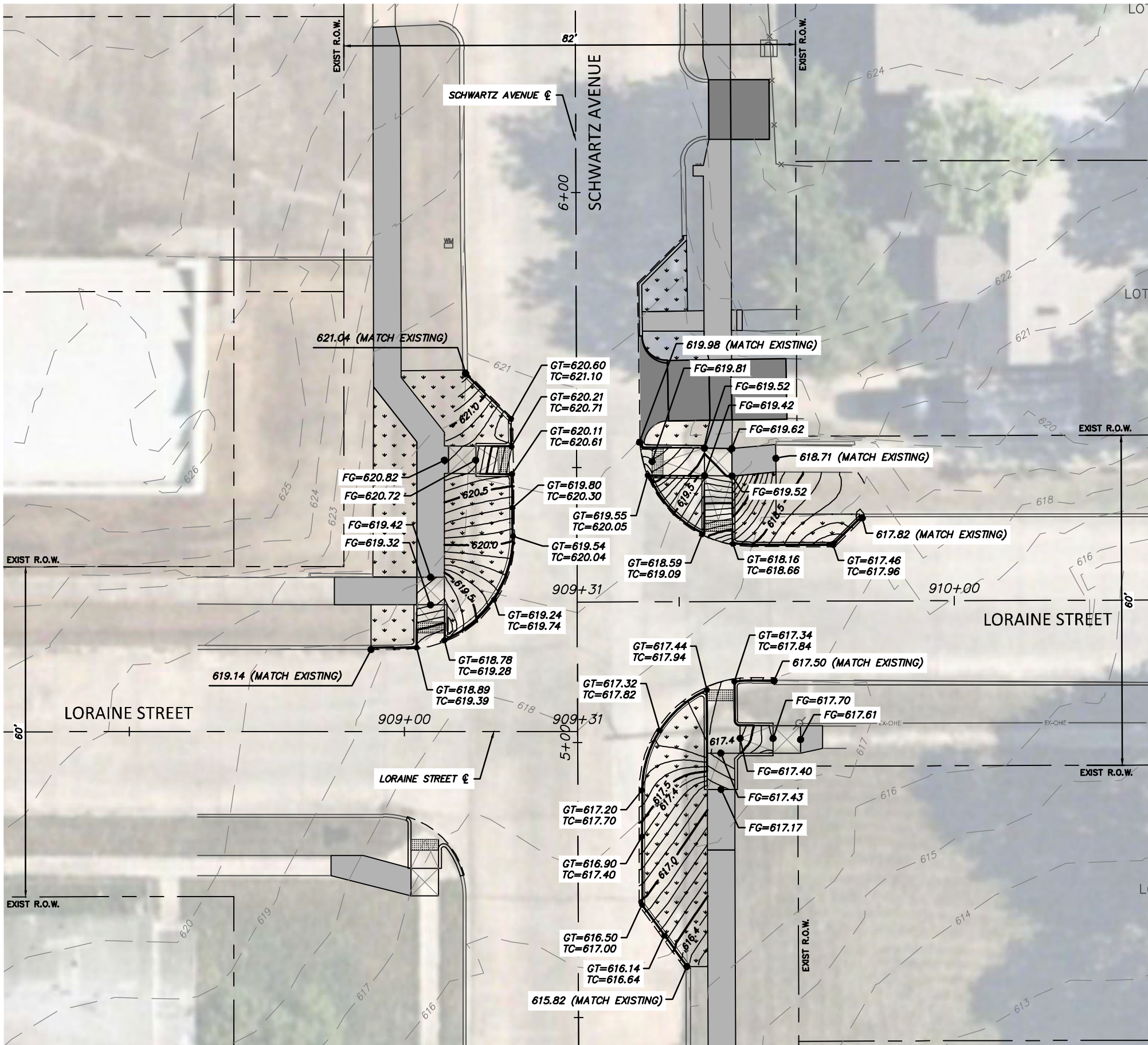

GRADING LEGEND	
	EXISTING MAJOR CONTOUR (5 FT)
	EXISTING MINOR CONTOUR (1 FT)
	PROPOSED MAJOR CONTOUR (0.5 FT)
	PROPOSED MINOR CONTOUR (0.1 FT)
	EXISTING STORM DRAIN
	FUTURE STORM DRAIN
	PROPOSED STORM
	STORMWATER FLOW DIRECTION
	CHANNEL FLOWLINE
	TOP OF CUT/TOE OF SLOPE
	PROPOSED GRADE SLOPES

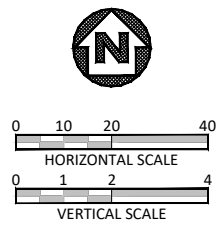

PROJECT ENGINEER: *Joshua Wright*

 DATE: 6/7/2021

- NOTES:
- VERTICAL PROFILES PROVIDED FOR GENERAL REFERENCE. CONTRACTOR SHALL LAY VERTICAL GRADE PER THESE PLANS AND AS NECESSARY DUE TO VARYING SITE CONDITIONS AT THE DIRECTION OF THE ENGINEER.
 - NEW SIDEWALK AND RAMPS TO ADHERE TO ALL APPLICABLE ADA, TAS, AND PROWAG REGULATIONS.
 - EXISTING DRIVEWAYS TO REMAIN HAVE 2% OR LESS CROSS SLOPE 48" WIDE OR GREATER AT SIDEWALK CROSSING LOCATION. PROPOSED SIDEWALK TO MEET AND MATCH EXISTING PAVEMENT AT THESE DRIVES.
 - EXISTING METERS & VALVES WITHIN LIMITS OF FINISHED GRADE TO BE ADJUSTED VERTICALLY TO MATCH. METERS & VALVES SHALL NOT BE PARTIALLY LOCATED IN DRIVEWAYS OR SIDEWALKS. A 6" CONCRETE APRON TO BE CONSTRUCTED AROUND THESE STRUCTURES. REFER TO DETAIL, SHEET 17.
 - CONTRACTOR SHALL CONFIRM LOCATION OF ALL EXISTING UTILITIES AND ELEVATIONS PRIOR TO CONSTRUCTION.

DATE	BY	REV	REVISION

550 Bailey Avenue
 Suite 400
 Fort Worth, TX 76107
 817-335-1121

PROJ NO. 101264 FILE NO. K-2630

© 2021

2018 SAFE ROUTES TO SCHOOL IMPROVEMENTS

**LORAIN ST AT SCHWARTZ AVE
 BULBOUT GRADING PLAN
 DIAMOND HILL ELEMENTARY SCHOOL**

FED. RD. DIV. NO.	STATE	PROJECT NO.	HIGHWAY NO.		
6	TEXAS	STP 2021(929)TP	VA		
STATE DISTRICT	COUNTY	CONTROL NO.	SECTION NO.	JOB NO.	SHEET NO.
FTW	TARRANT	0902	90	082	255

DISCLAIMER: The use of this standard is governed by the "Texas Engineering Practice Act". No warranty of any kind is made by TxDOT for any purpose whatsoever. TxDOT assumes no responsibility for the conversion of this standard to other formats or for incorrect results or damages resulting from its use.

DATE: FILE:

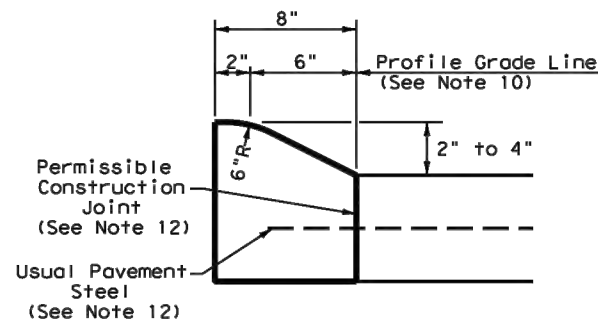

**TYPE I CURB (MONOLITHIC)
2" - 4" HEIGHT**

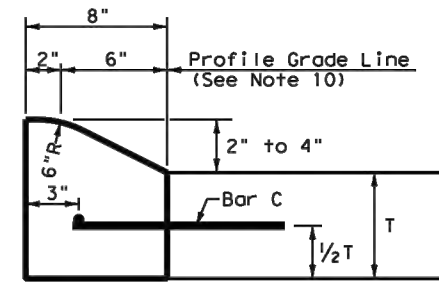

**TYPE I CURB
2" - 4" HEIGHT**

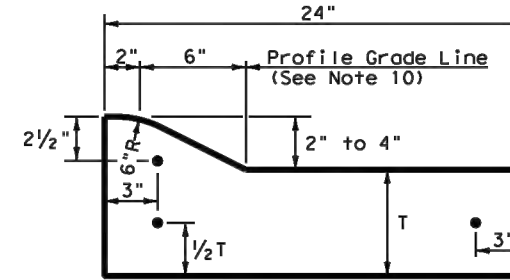

**TYPE I CURB AND GUTTER
2" - 4" HEIGHT**

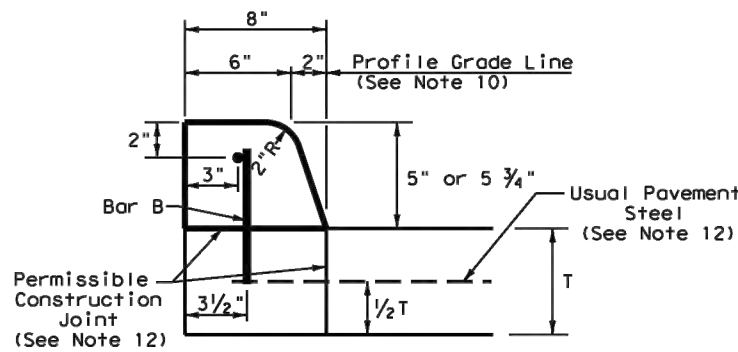

**TYPE II CURB (MONOLITHIC)
5" - 5 3/4" HEIGHT**

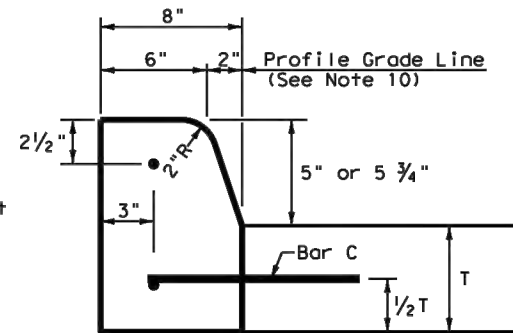

**TYPE II CURB
5" - 5 3/4" HEIGHT**

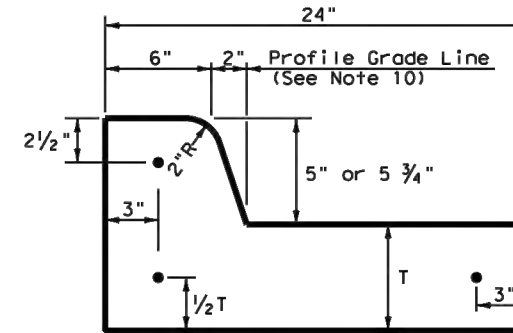

**TYPE II CURB AND GUTTER
5" - 5 3/4" HEIGHT**

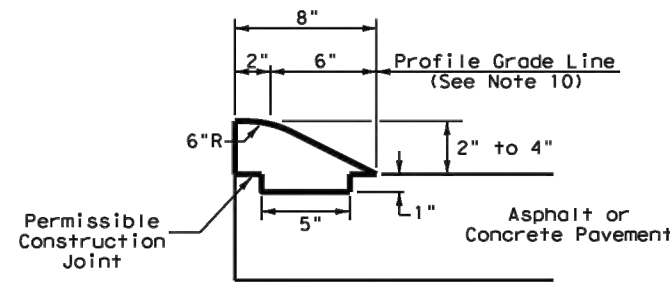

**TYPE III CURB (KEYED)
2" - 4" HEIGHT**

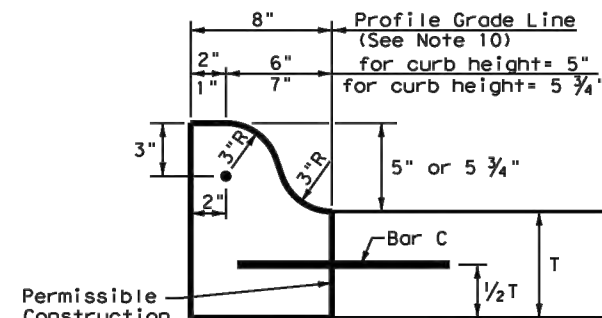

**TYPE IIa CURB
5" - 5 3/4" HEIGHT**

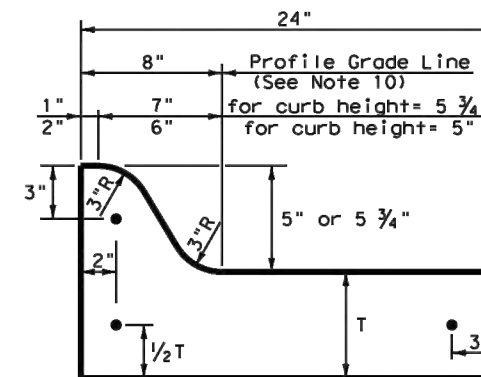

**TYPE IIa CURB AND GUTTER
5" - 5 3/4" HEIGHT**

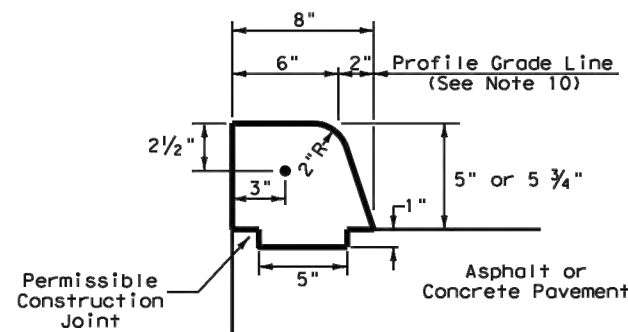

**TYPE IV CURB (KEYED)
5" - 5 3/4" HEIGHT**

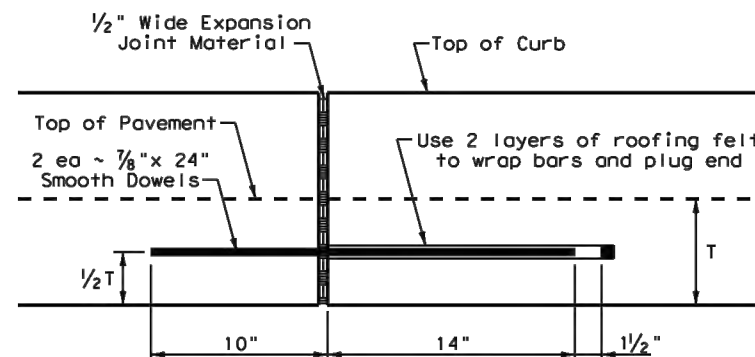

EXPANSION JOINT DETAIL

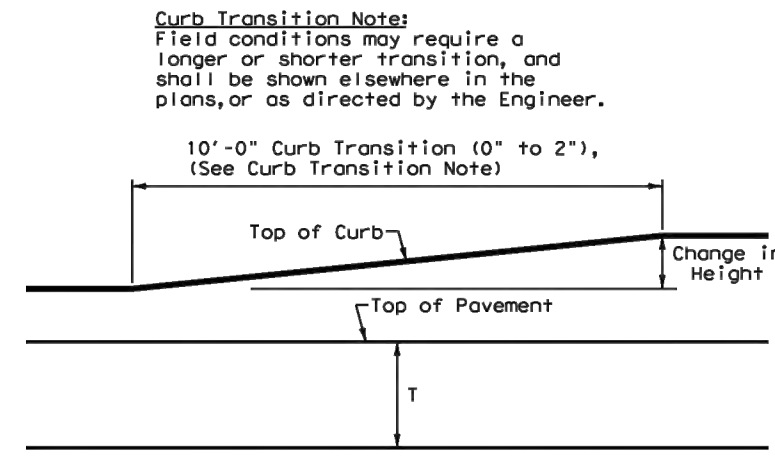

CURB TRANSITION

Note: To be paid for as Highest Curb

General Notes

- All materials and construction shall be in accordance with Item 529, "Concrete Curb, Gutter, and Combined Curb and Gutter."
- Concrete shall be Class A.
- When reinforcing bars are used, they shall be No.4 unless otherwise shown. The use of synthetic fiber in lieu of steel reinforcing is acceptable, provided the fiber producer is on the Department Producer List (MPL), maintained by TxDOT, Construction Division.
- Round exposed sharp edges with a rounding tool, to a minimum radius of 1/4 inch.
- All existing curbs and driveways to be removed shall be sawed or removed at existing joints.
- Where concrete curb is placed on existing concrete pavement, the pavement shall be drilled and the reinforcing bars grouted in place.
- Expansion and contraction joints shall be constructed to match pavement joints in all curbs and curb and gutter adjacent to jointed concrete pavement. Where placement of curb or curb and gutter is not adjacent to concrete pavement, expansion joints shall be provided at structures, curb returns at streets, and at locations directed by The Engineer.
- Vertical and horizontal dowel bars and transverse reinforcing bars shall be placed at four feet C-C.
- Dimension 'T' shown is the thickness of concrete pavement. When curb is installed adjacent to flexible pavement dimension 'T' is 8" maximum.
- Usual profile grade line. Refer to typical sections and plan-profile sheets for exact locations.
- One-half inch expansion joint material shall be provided where curb or curb and gutter is adjacent to sidewalk or riprap.
- When vertical permissible construction joints are used, resulting in a longitudinal construction joint in the pavement, the longitudinal pavement steel shall be placed in accordance with pavement details shown elsewhere in the plans for longitudinal construction joints. Reinforcing steel for curb section shall then conform to that required for concrete curb.

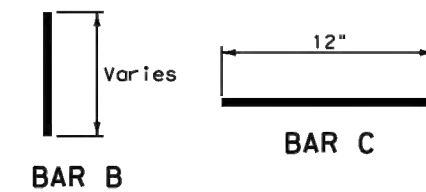

				Design Division Standard	
CONCRETE CURB AND GUTTER					
CCCG-12					
FILE: cccg12.dgn	DN: TxDOT	CK: AM	DW: VP	CK: VP	
© TxDOT: 1995	CONT	SECT	JOB	HIGHWAY	
REVISIONS	0902	90	082	CS	
UPDATED 2012 - VP	DIST	COUNTY	SHEET NO.		
	FTW	TARRANT	256		

DISCLAIMER: THIS STANDARD IS COVERED BY THE "TEXAS ENGINEERING PRACTICE ACT". NO WARRANTY OF ANY KIND IS MADE BY TxDOT FOR ANY PURPOSE WHATSOEVER. TxDOT ASSUMES NO RESPONSIBILITY FOR THE CONVERSION OF THIS STANDARD TO OTHER FORMATS OR FOR INCORRECT RESULTS OR DAMAGES RESULTING FROM ITS USE.

https://www.dot.state.tx.us/ftw/spec/info/standard.htm
 11/24/2020 10:41:22 AM
 P:\PROJECTS\TXDOT\161215 FTW Standards Revision\CADD\Modifications in Progress\cswd-ftw.dgn

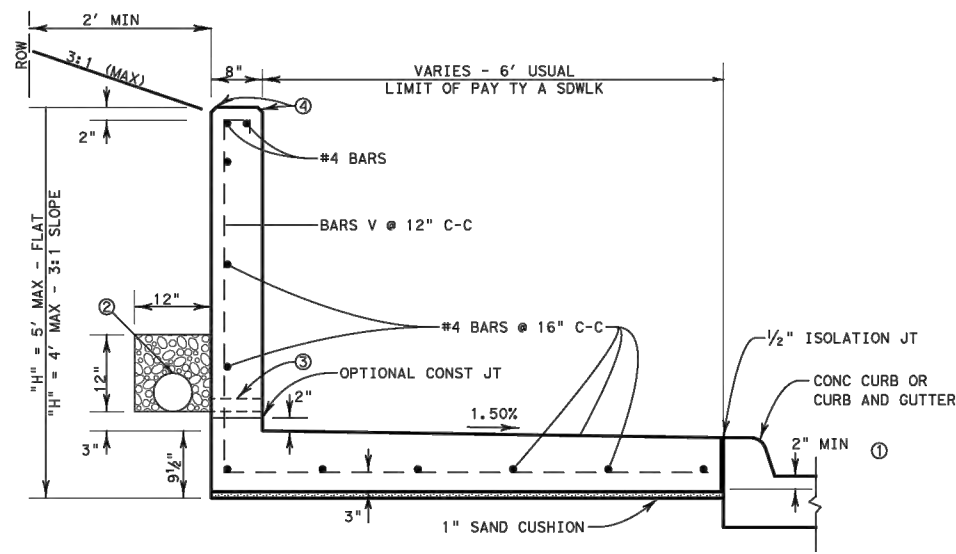

TYPE A SIDEWALK-ADJACENT TO CURB

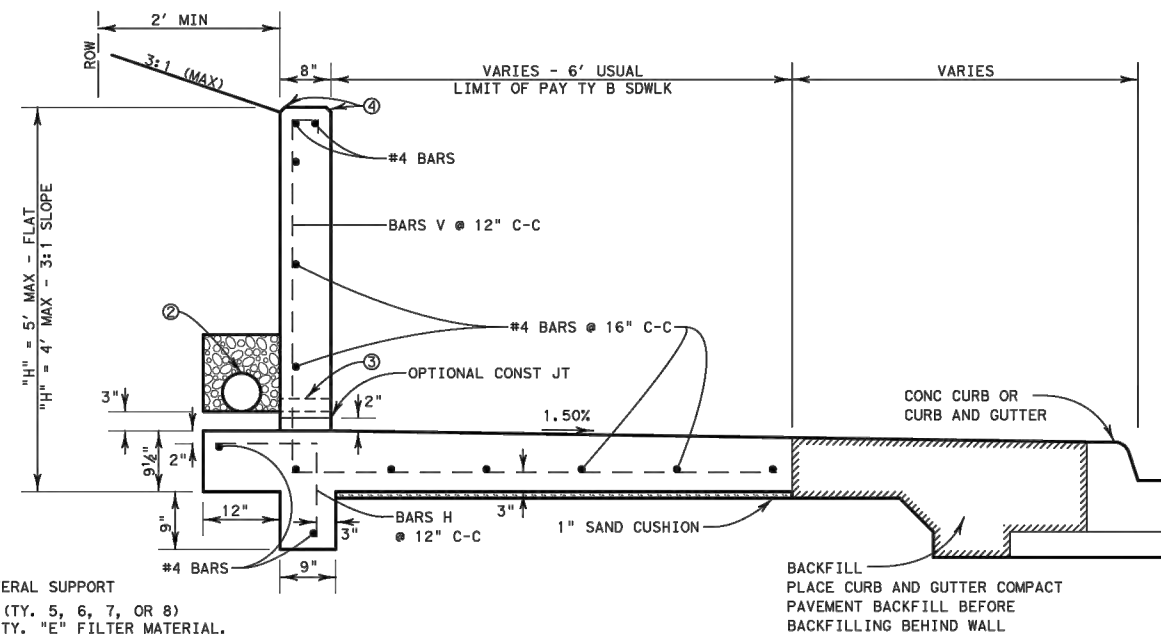

TYPE B SIDEWALK-REMOTE FROM CURB

- ① 2" MINIMUM REQUIRED FOR LATERAL SUPPORT
- ② INSTALL 6" PIPE UNDERDRAIN (TY. 5, 6, 7, OR 8) ENTIRE LENGTH OF WALL. USE TY. "E" FILTER MATERIAL. SLOPE TO DRAIN AND CONNECT TO STORM DRAIN.
- ③ IF, IN THE OPINION OF THE ENGINEER, USE OF UNDERDRAIN IS IMPRACTICAL, INSTALL WEEP HOLES AS SHOWN.
- ④ 3/4" CHAMFER

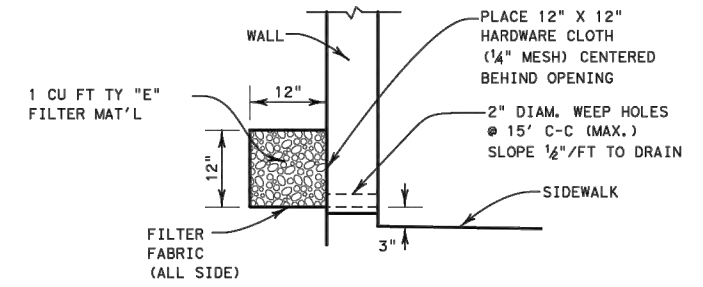

WEEP HOLE DETAIL

SPECIAL CONCRETE SIDEWALK w/ INTEGRATED RETAINING WALL

N. T. S.

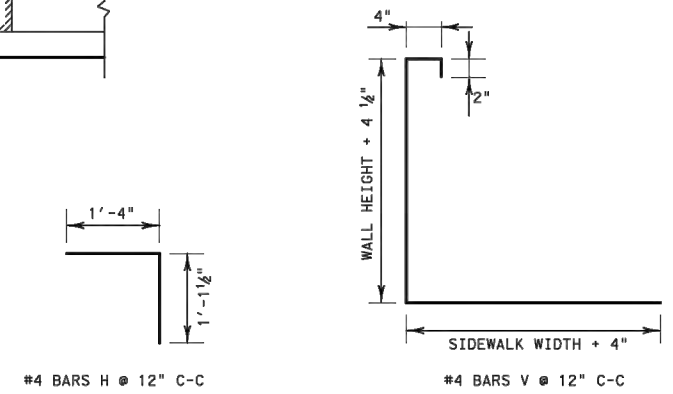

REINFORCING STEEL DETAILS

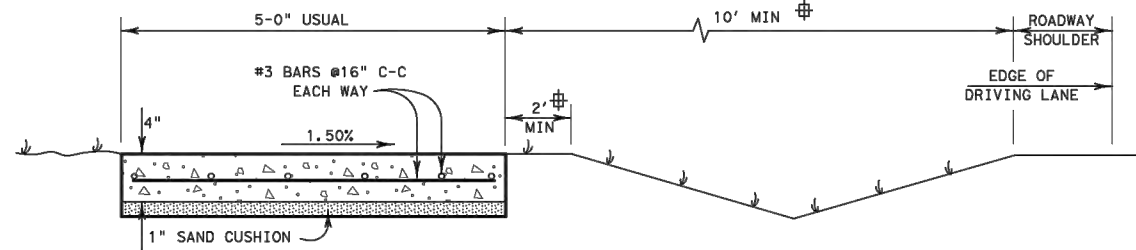

**CONCRETE SIDEWALK
(ROADWAY W/O CURB)**

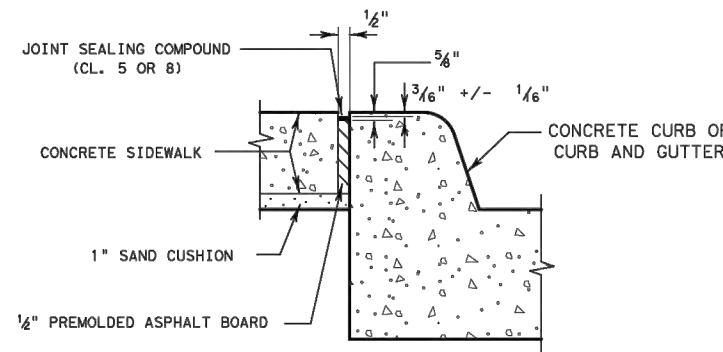

1/2\"/>

GENERAL NOTES:

1. ALL CONCRETE SHALL BE CLASS "C".
2. ALL REINFORCING STEEL SHALL BE GRADE 60, # 4 BARS UNLESS OTHERWISE INDICATED.
3. SEE PLAN SHEETS FOR LOCATIONS OF SIDEWALKS AND RETAINING WALLS.
4. LONGITUDINAL SLOPE OF SIDEWALKS SHALL NOT EXCEED 5% EXCEPT IN CASES WHERE THE ADJACENT ROADWAY SLOPE EXCEEDS 5%. IF ROADWAY SLOPE EXCEEDS 5%, LONGITUDINAL SLOPE OF SIDEWALK MAY MATCH THAT OF ROADWAY.
5. IF SIDEWALK WIDTH IS LESS THAN 5', PROVIDE 5' X 5' PASSING AREAS AT INTERVALS NOT TO EXCEED 200' SPACING.
6. RETAINING WALL WILL BE SUBSIDIARY TO THE ITEM, "CONC SIDEWALKS (SPECIAL) (TYPE A)" OR "CONC SIDEWALKS (SPECIAL) (TYPE B)", WITH LIMITS OF PAY AS SHOWN.
7. SURFACE TREATMENT OF RETAINING WALL FACE DETAILED ELSEWHERE IN THE PLANS.
8. SEE PED STANDARDS FOR TREATMENT AT INTERSECTIONS AND CROSSWALKS.

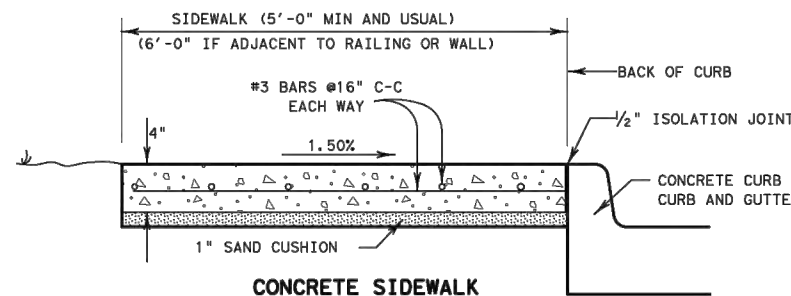

**CONCRETE SIDEWALK
(ADJACENT TO CURB)**

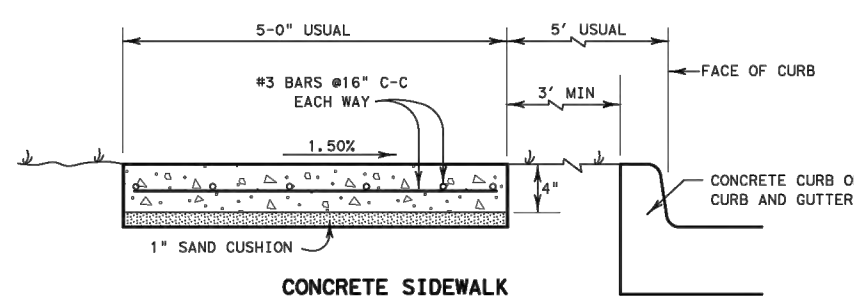

**CONCRETE SIDEWALK
(REMOTE FROM CURB)**

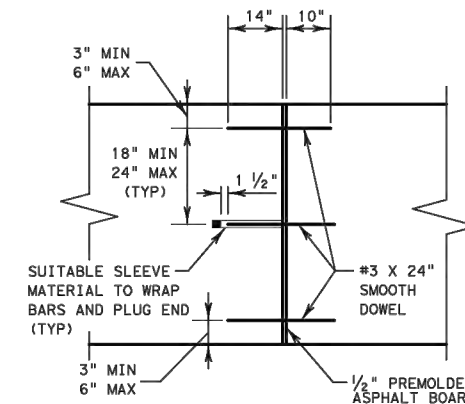

TRANSVERSE EXPANSION JOINT

CONCRETE SIDEWALK DETAILS

N. T. S.

©2020 by Texas Department of Transportation;
 All Rights Reserved

		Fort Worth District Standard	
CONCRETE SIDEWALK DETAILS CSWD (FTW)			
ORIGINAL DRAWING: 05/2019	cswd-ftw.dgn	PROJECT NO.	SHEET NO.
DATE	REVISIONS	STP 2021(929)TP	257
05/2019	NEW STANDARD	STATE	COUNTY
11/2020	REVISE JOINT NOMENCLATURE, REVISE ALLOWABLE SEALANT TYPES	TEXAS	TARRANT
		CONT.	SECT.
		0902	90
		JOB	HIGHWAY NO.
		082	VA

DISCLAIMER: THIS STANDARD IS COVERED BY THE "TEXAS ENGINEERING PRACTICE ACT". NO WARRANTY OF ANY KIND IS MADE BY TxDOT FOR ANY PURPOSE WHATSOEVER. TxDOT ASSUMES NO RESPONSIBILITY FOR THE CONVERSION OF THIS STANDARD TO OTHER FORMATS OR FOR INCORRECT RESULTS OR DAMAGES RESULTING FROM ITS USE.

https://www.dot.state.tx.us/ftw/spec/info/standard.htm
 11/10/2020 10:09:34 AM
 P:\PROJECTS\TXDOT\1612115 FTW Standards Revision\CADD\Modifications in Progress\odd-ftw.dgn

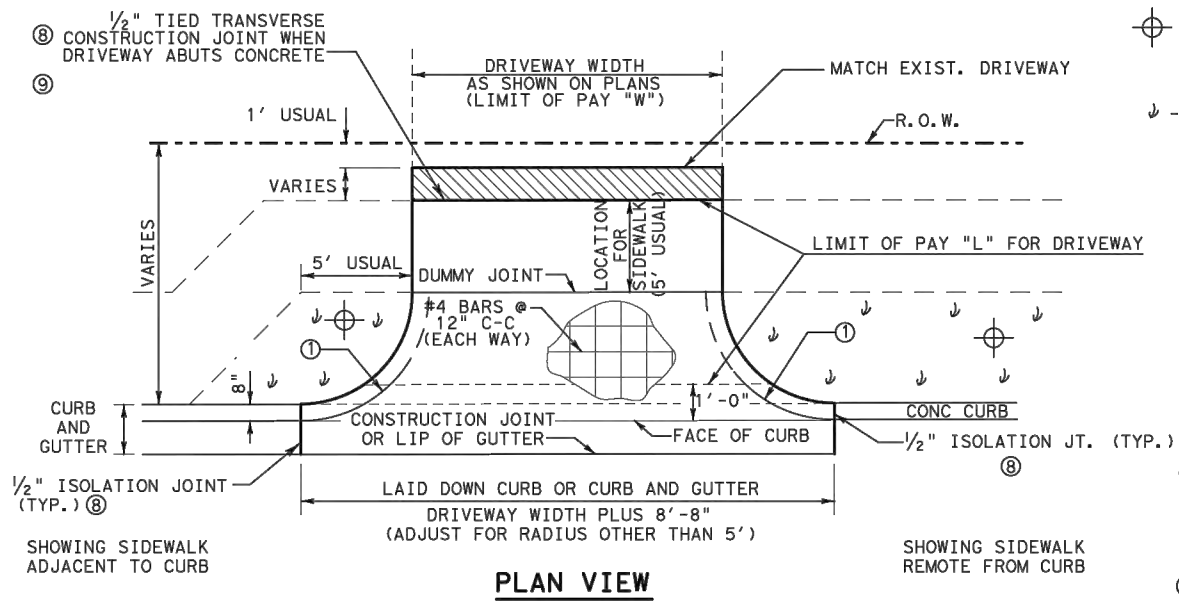

PAY AREA FOR DRIVEWAY SHALL BE THE PRODUCT OF "L" x "W"

S.Y. NON-PAY CONCRETE IN DRIVEWAY RADIUS 2-90° RADII (FT)	NON-PAY CONC. (S.Y.)
5	0.42
10	3.04
15	10.73
20	15.36
25	29.81
30	37.19

- ① RADII AS SHOWN ON PLANS
SEE ROADWAY DESIGN MANUAL, APPENDIX C FOR RECOMMENDED RADII.
- ② FULL DEPTH SAW CUT IF CONCRETE

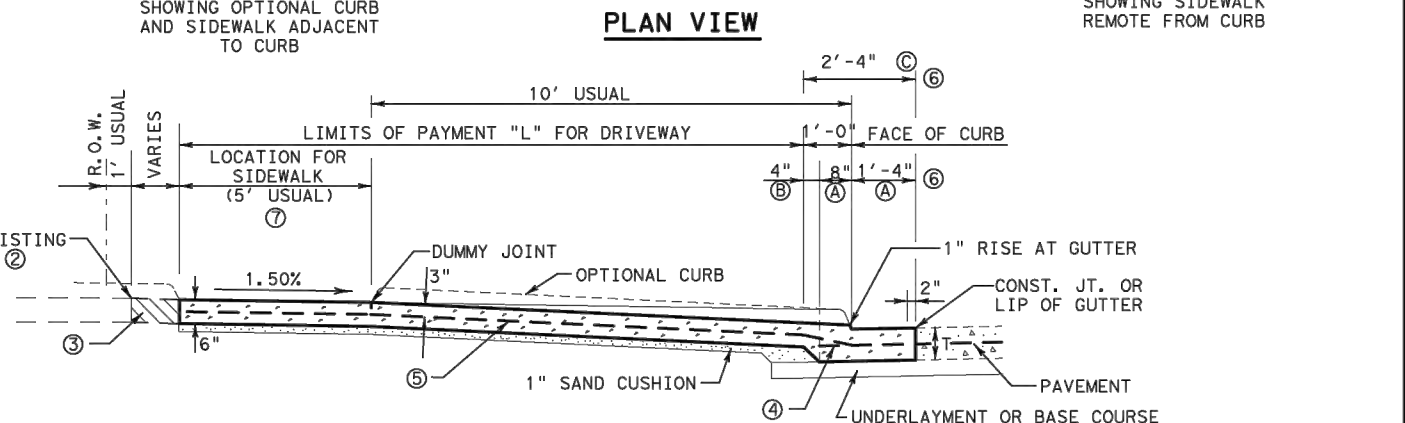
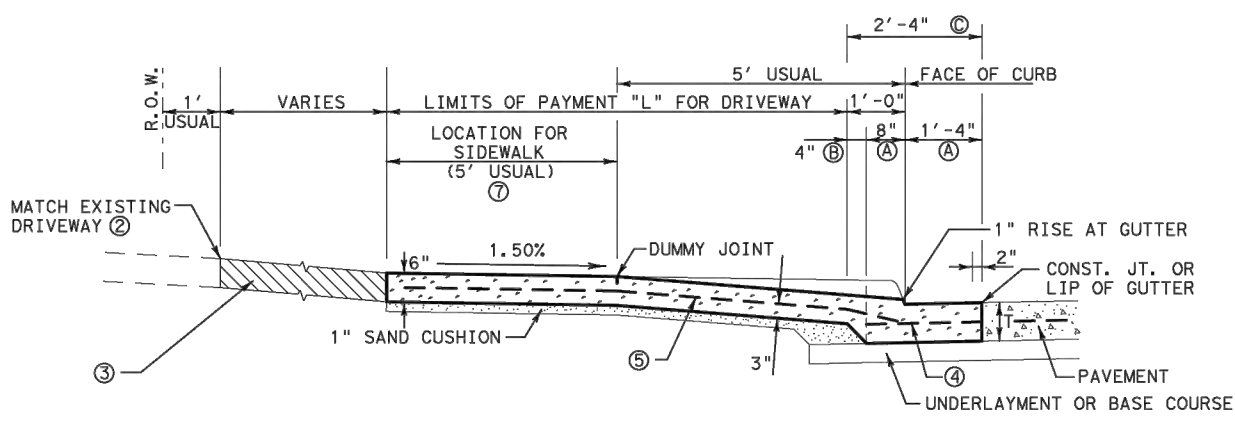
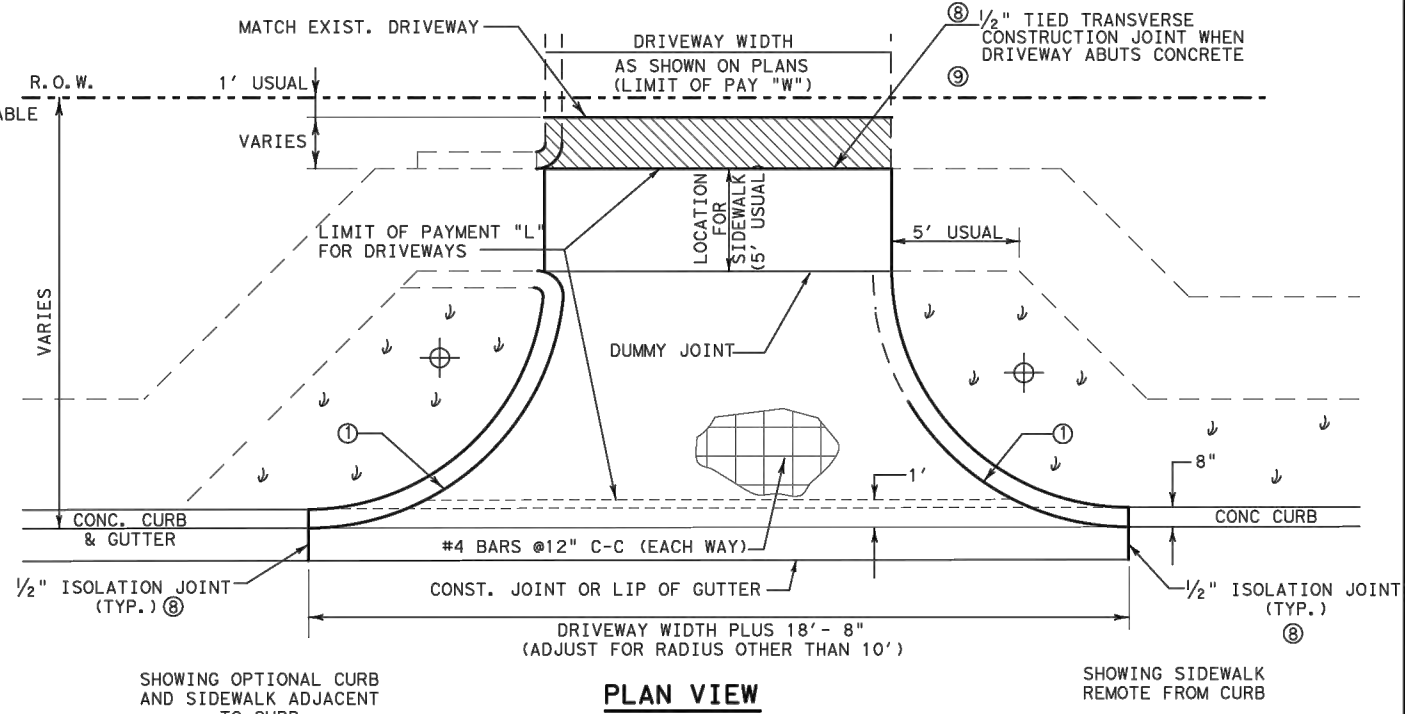

SECTION VIEW
CONCRETE RESIDENTIAL DRIVEWAY

SECTION VIEW
CONCRETE COMMERCIAL DRIVEWAY

- ③ REPLACE EXISTING DRIVEWAY WITH EQUAL OR BETTER MATERIAL:
 IF CONCRETE, PAY FOR AS CONCRETE DRIVEWAY.
 IF HOT MIX OR OTHER MATERIAL, PAY FOR IN ACCORDANCE WITH APPROPRIATE BID ITEMS.
- ④ WHERE DRIVEWAY IS ADJACENT TO CONCRETE PAVEMENT, 36" - #4 TIE BAR, 12" EMBEDMENT INTO PAVEMENT (CAST-IN-PLACE OR DRILLED AND GROUTED). SPACING TO MATCH TRANSVERSE STEEL IN CONCRETE PAVEMENT.
 MULTIPLE-PIECE TIE BARS OR 24" EXTENSION OF TRANSVERSE PAVING STEEL MAY BE USED IN LIEU OF TIE BARS.
 LONGITUDINAL STEEL IN GUTTER PORTION TO MATCH CONCRETE PAVEMENT OR CONCRETE CURB AND GUTTER DETAILS.
- ⑤ #4 BARS @ 12" C-C EACH WAY (EXTEND TO FACE OF CURB) BEND AS REQ'D TO TIE TO PAVING STEEL OR TIE BARS.
- ⑥ IF ADJACENT TO CONCRETE PAVEMENT:
 A PAID FOR AS CONCRETE PAVEMENT,
 B PAID FOR AS CONCRETE CURB.
 IF ADJACENT TO HOT MIX OR FLEXIBLE PAVEMENT:
 C PAID FOR AS CONCRETE CURB AND GUTTER.
 T = THICKNESS OF CONCRETE PAVEMENT OR CONCRETE CURB AND GUTTER
- ⑦ LOCATION FOR SIDEWALK TO BE PROVIDED ON ALL DRIVEWAYS FOR SIDEWALK DETAILS, SEE STANDARD CSWD (FTW)
- ⑧ SEE STANDARD JS (FTW) FOR JOINT DETAILS.
- ⑨ IF, IN THE OPINION OF THE ENGINEER, ADJACENT CONCRETE IS NOT SOUND, 1/2" ISOLATION JOINT MAY BE USED IN LIEU OF TIED JOINT.

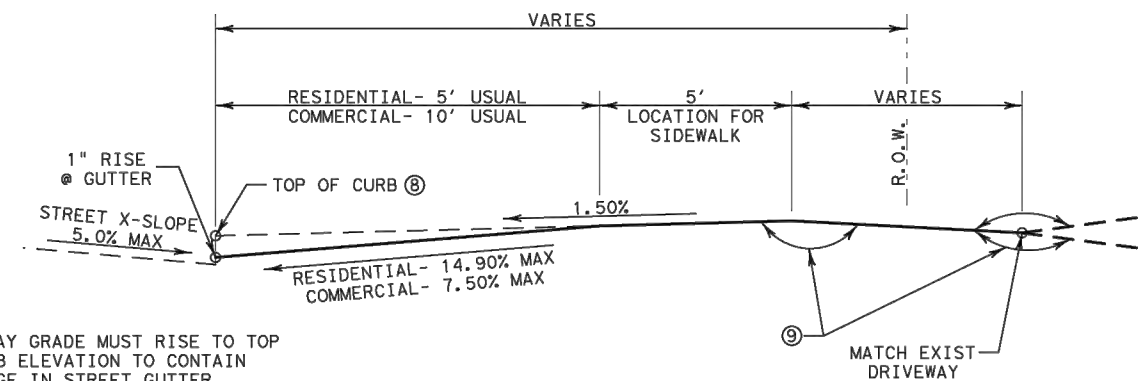
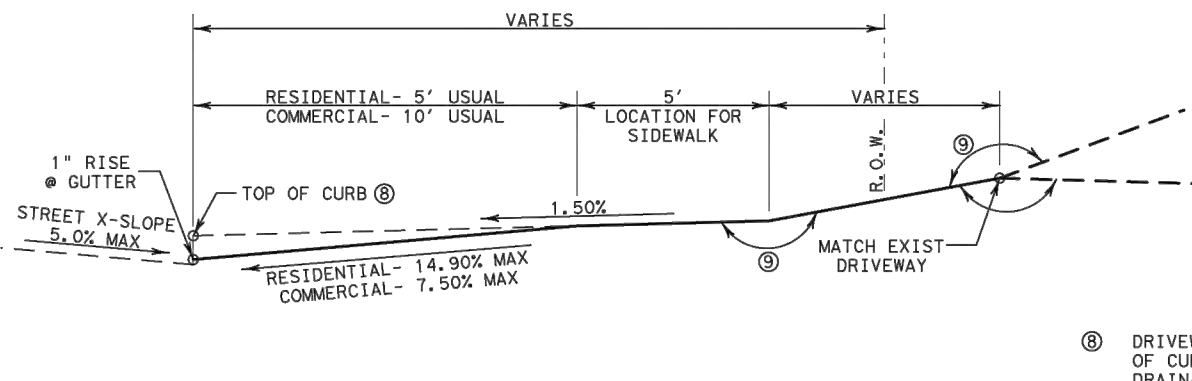

SAG CONDITION

CREST CONDITION

ALLOWABLE DRIVEWAY GRADES

Texas Department of Transportation		Fort Worth District Standard	
CONCRETE DRIVEWAY DETAILS CDD (FTW)			
ORIGINAL DRAWING: 05/2019 odd-ftw.dgn	PROJECT NO. STP 2021(929)TP	SHEET NO. 258	
DATE: 05/2019	REVISIONS: NEW STANDARD	STATE: TEXAS	COUNTY: TARRANT
11/2020	REVISED JOINT NOMENCLATURE REVISED NOTE 4 ADD NOTE 9	CONT.: 0902	SECT.: 90
		JOB: 082	HIGHWAY NO.: N/A

DISCLAIMER: The use of this standard is governed by the "Texas Engineering Practice Act". No warranty of any kind is made by TxDOT for any purpose whatsoever. TxDOT assumes no responsibility for the conversion of this standard to other formats or for incorrect results or damages resulting from its use.

DATE: FILE:

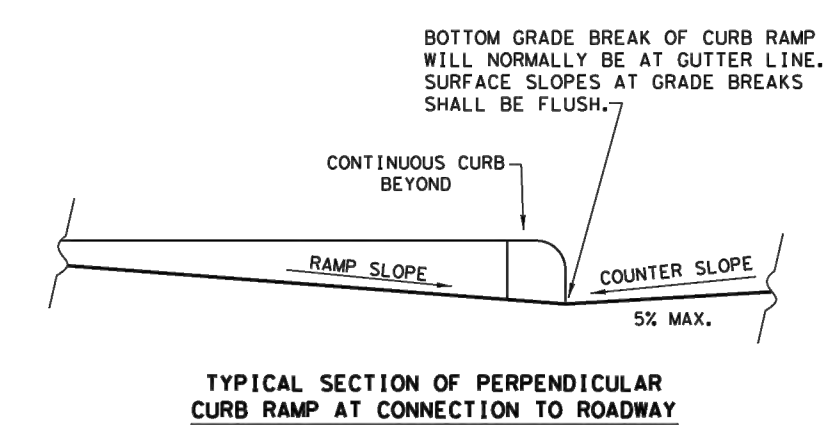
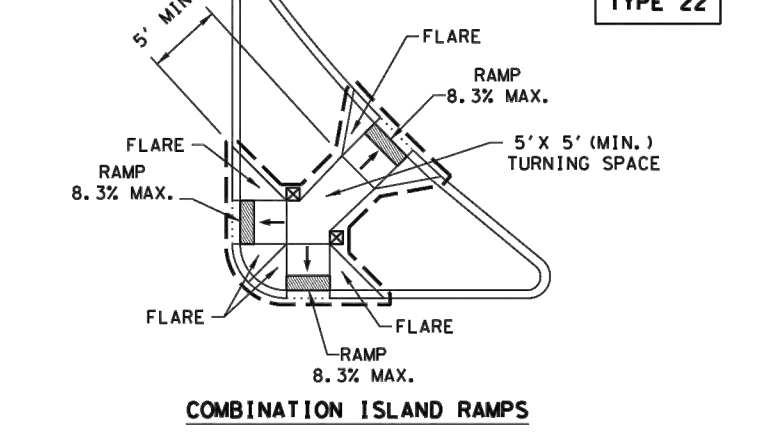
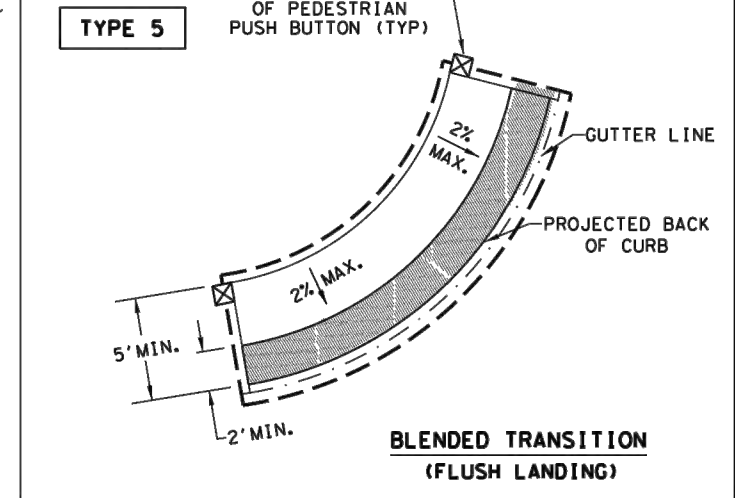
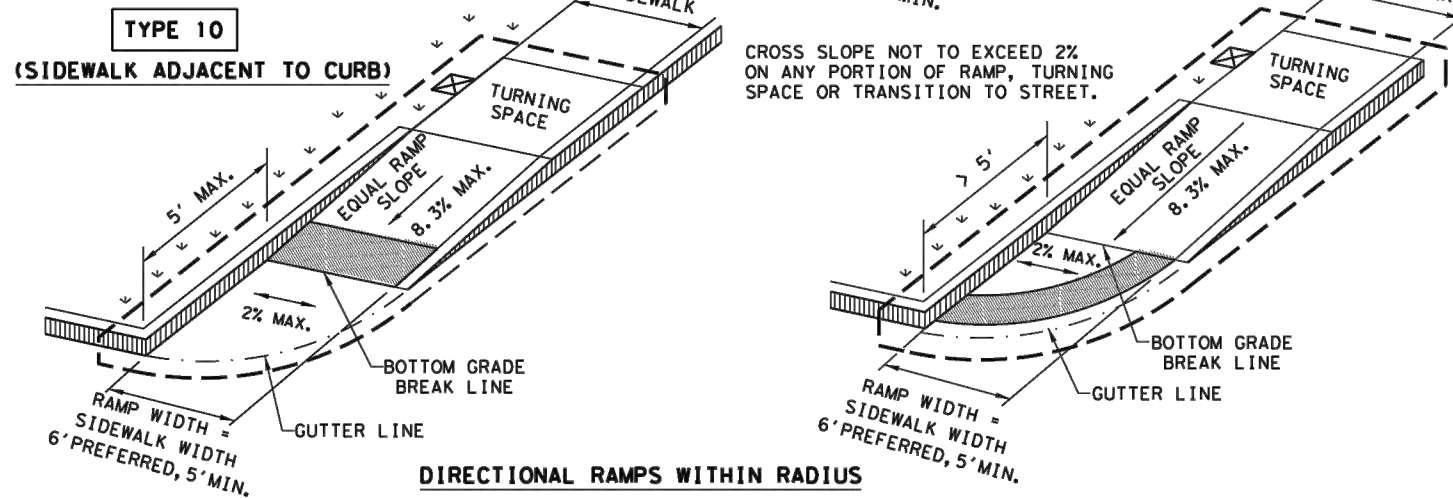
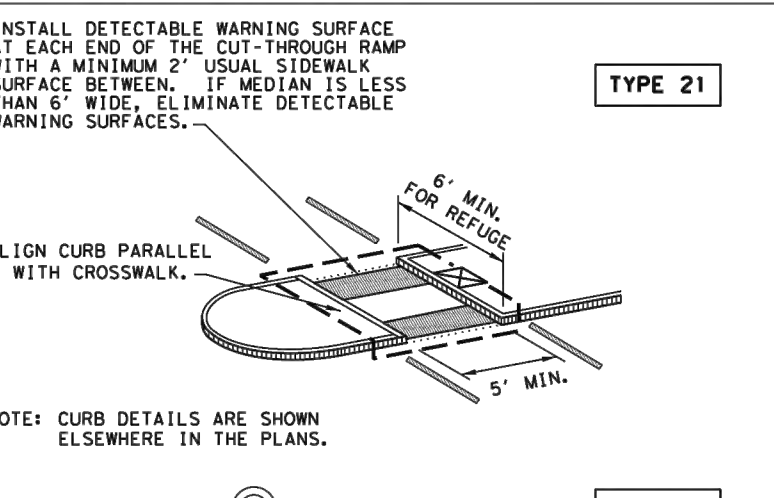
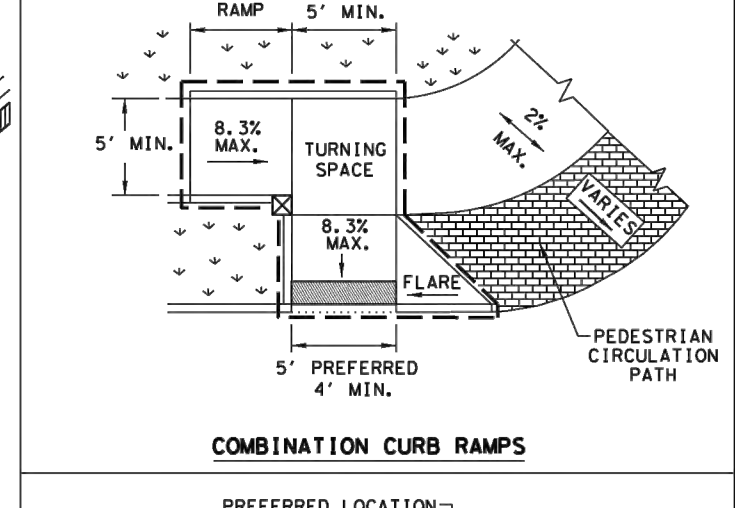
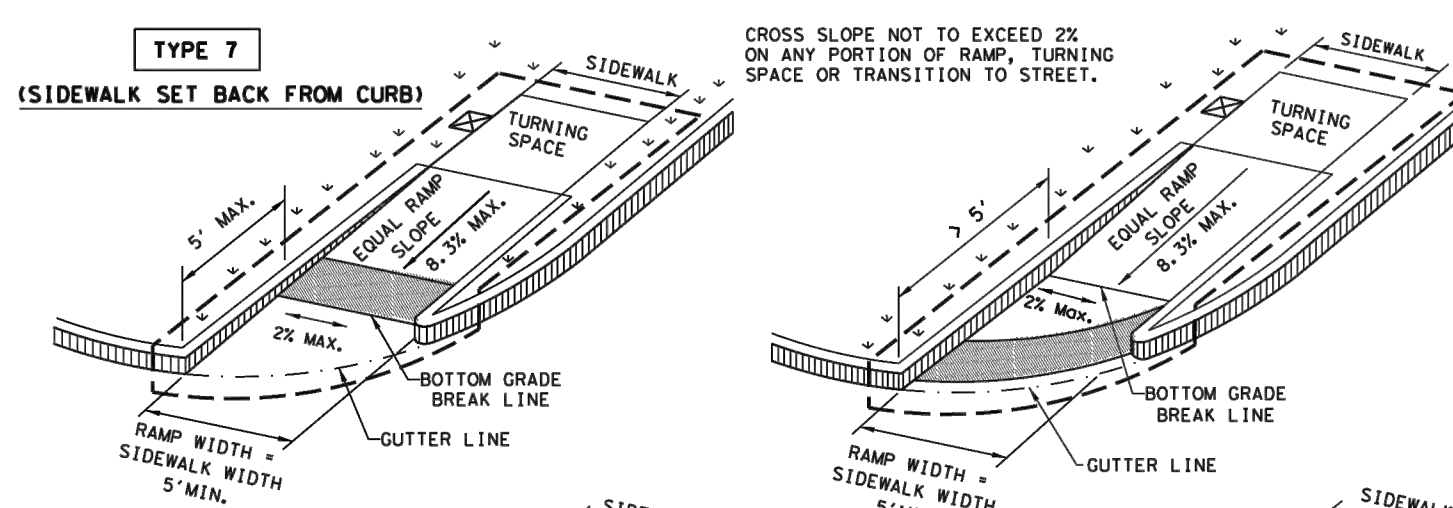
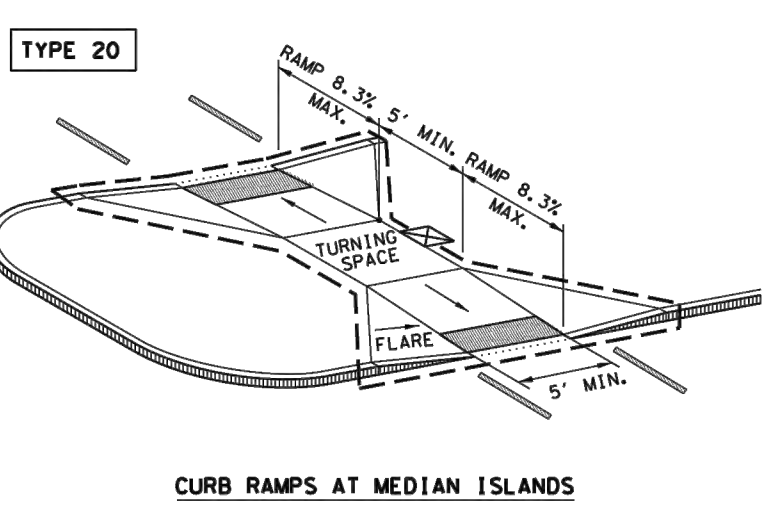
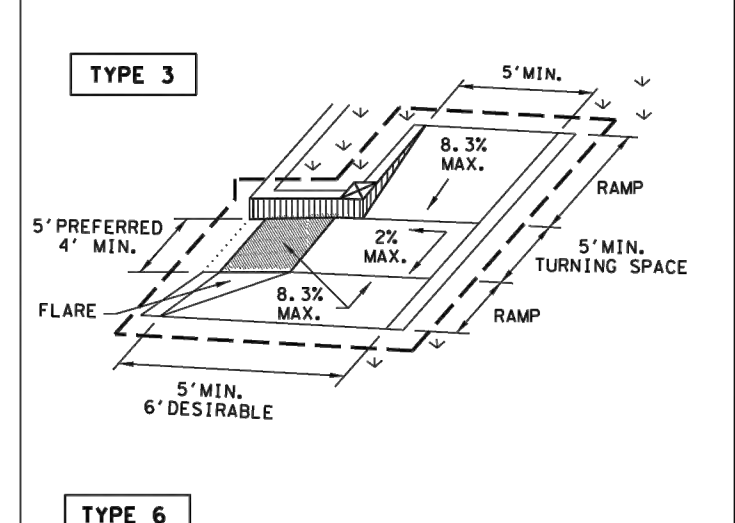
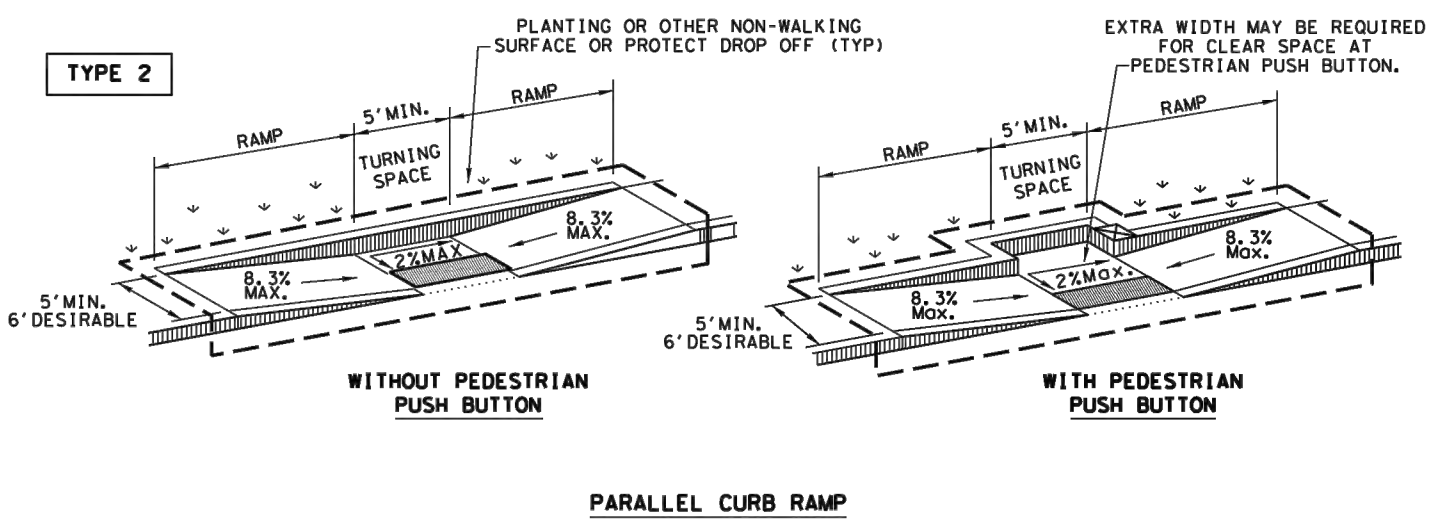
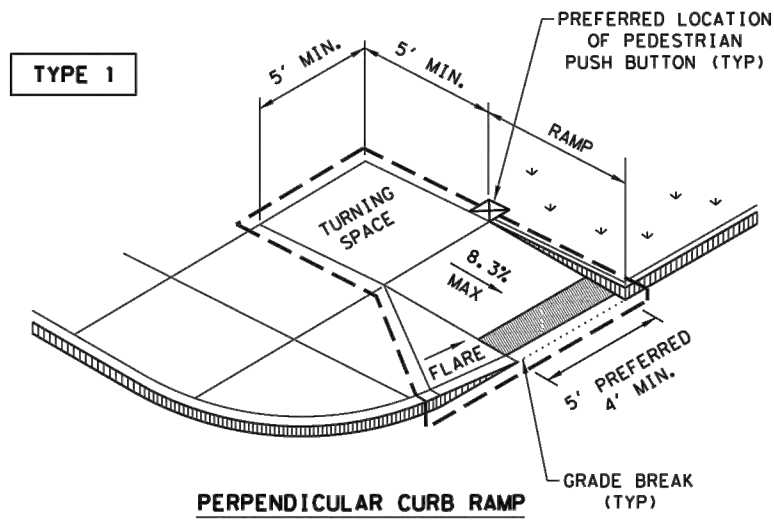

NOTES / LEGEND:
SEE GENERAL NOTES ON SHEET 2 OF 4 FOR MORE INFORMATION.

DENOTES PLANTING OR NON-WALKING SURFACE NOT PART OF PEDESTRIAN CIRCULATION PATH.

DENOTES PREFERRED LOCATION OF PEDESTRIAN PUSH BUTTON IF APPLICABLE.

Detectable Warning Surface: [Symbol]

Grade Break: [Symbol]

Ramp Limits of Payment: [Symbol]

Gutter Line: [Symbol]

SHEET 1 OF 4

Design Division Standard

PEDESTRIAN FACILITIES CURB RAMPS

PED-18

FILE: ped18	DW: TxDOT	DW: VP	CK: KM	CK: PK & JG
© TxDOT: MARCH, 2002	CONT	SECT	JOB	HIGHWAY
REVISIONS	0902	90	082	VA
REVISED 08, 2005	DIST	COUNTY	SHEET NO.	
REVISED 06, 2012	FTW	TARRANT	259	
REVISED 01, 2018				

DISCLAIMER: The use of this standard is governed by the "Texas Engineering Practice Act". No warranty of any kind is made by TxDOT for any purpose whatsoever. TxDOT assumes no responsibility for the conversion of this standard to other formats or for incorrect results or damages resulting from its use.

GENERAL NOTES

CURB RAMPS

1. Install a curb ramp or blended transition at each pedestrian street crossing.
2. All slopes shown are maximum allowable. Cross slopes of 1.5% and lesser running should be used. Adjust curb ramp length or grade of approach sidewalks as directed.
3. Maximum allowable cross slope on sidewalk and curb ramp surfaces is 2%.
4. The minimum sidewalk width is 5'. Where the sidewalk is adjacent to the back of curb, a 6' sidewalk width is desirable. Where a 5' sidewalk cannot be provided due to site constraints, sidewalk width may be reduced to 4' for short distances. 5' x 5' passing areas at intervals not to exceed 200' are required.
5. Turning Spaces shall be 5' x 5' minimum. Cross slope shall be maximum 2%.
6. Clear space at the bottom of curb ramps shall be a minimum of 4' x 4' wholly contained within the crosswalk and wholly outside the parallel vehicular travel path.
7. Provide flared sides where the pedestrian circulation path crosses the curb ramp. Flared sides shall be sloped at 10% maximum, measured parallel to the curb. Returned curbs may be used only where pedestrians would not normally walk across the ramp, either because the adjacent surface is planted, substantially obstructed, or otherwise protected.
8. Additional information on curb ramp location, design, light reflective value and texture may be found in the latest draft of the Proposed Guidelines for Pedestrian Facilities in the Public Right of Way (PROWAG) as published by the U.S. Architectural and Transportation Barriers Compliance Board (Access Board).
9. To serve as a pedestrian refuge area, the median should be a minimum of 6' wide, measured from back of curbs. Medians should be designed to provide accessible passage over or through them.
10. Small channelization islands, which do not provide a minimum 5' x 5' landing at the top of curb ramps, shall be cut through level with the surface of the street.
11. Crosswalk dimensions, crosswalk markings and stop bar locations shall be as shown elsewhere in the plans. At intersections where crosswalk markings are not required, curb ramps shall align with theoretical crosswalks unless otherwise directed.
12. Provide curb ramps to connect the pedestrian access route at each pedestrian street crossing. Handrails are not required on curb ramps.
13. Curb ramps and landings shall be constructed and paid for in accordance with Item 531 "Sidewalks".
14. Place concrete at a minimum depth of 5" for ramps, flares and landings, unless otherwise directed.
15. Furnish and install No. 3 reinforcing steel bars at 18" o.c. both ways, unless otherwise directed.
16. Provide a smooth transition where the curb ramps connect to the street.
17. Curbs shown on sheet 1 within the limits of payment are considered part of the curb ramp for payment, whether it is concrete curb, gutter, or combined curb and gutter.
18. Existing features that comply with applicable standards may remain in place unless otherwise shown on the plans.

DETECTABLE WARNING MATERIAL

19. Curb ramps must contain a detectable warning surface that consists of raised truncated domes complying with PROWAG. The surface must contrast visually with adjoining surfaces, including side flares. Furnish and install an approved cast-in-place dark brown or dark red detectable warning surface material adjacent to uncolored concrete, unless specified elsewhere in the plans.
20. Detectable Warning Materials must meet TxDOT Departmental Materials Specification DMS 4350 and be listed on the Material Producer List. Install products in accordance with manufacturer's specifications.
21. Detectable warning surfaces must be firm, stable and slip resistant.
22. Detectable warning surfaces shall be a minimum of 24 inches in depth in the direction of pedestrian travel, and extend the full width of the curb ramp or landing where the pedestrian access route enters the street.
23. Detectable warning surfaces shall be located so that the edge nearest the curb line is at the back of curb and neither end of that edge is greater than 5 feet from the back of curb. Detectable warning surfaces may be curved along the corner radius.
24. Shaded areas on Sheet 1 of 4 indicate the approximate location for the detectable warning surface for each curb ramp type.

DETECTABLE WARNING PAVERS (IF USED)

25. Furnish detectable warning paver units meeting all requirements of ASTM C-936, C-33. Lay in a two by two unit basket weave pattern or as directed.
26. Lay full-size units first followed by closure units consisting of at least 25 percent (25%) of a full unit. Cut detectable warning paver units using a power saw.

SIDEWALKS

27. Provide clear ground space at operable parts, including pedestrian push buttons. Operable parts shall be placed within unobstructed reach range specified in PROWAG section R406.
28. Place traffic signal or illumination poles, ground boxes, controller boxes, signs, drainage facilities and other items so as not to obstruct the pedestrian access route or clear ground space.
29. Street grades and cross slopes shall be as shown elsewhere in the plans.
30. Changes in level greater than 1/4 inch are not permitted.
31. The least possible grade should be used to maximize accessibility. The running slope of sidewalks and crosswalks within the public right of way may follow the grade of the parallel roadway. Where a continuous grade greater than five percent (5%) must be provided, handrails may be desirable to improve accessibility. Handrails may also be needed to protect pedestrians from potentially hazardous conditions. If provided, handrails shall comply with PROWAG R409.
32. Handrail extensions shall not protrude into the usable landing area or into intersecting pedestrian routes.
33. Driveways and turnouts shall be constructed and paid for in accordance with Item "Intersections, Driveways and Turnouts". Sidewalks shall be constructed and paid for in accordance with Item, "Sidewalks".
34. Sidewalk details are shown elsewhere in the plans.

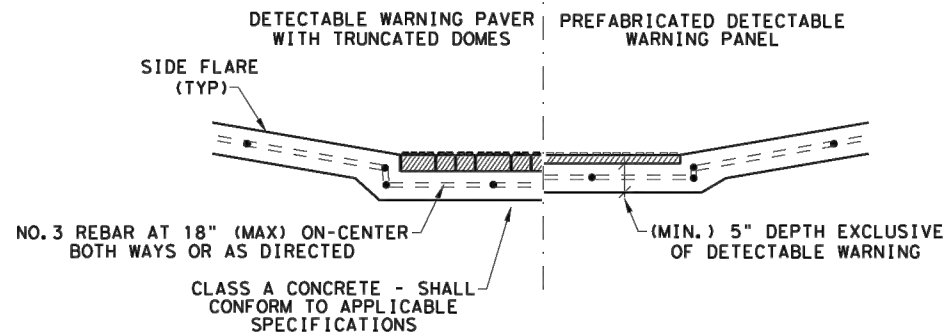

SECTION VIEW DETAIL
CURB RAMP AT DETECTIBLE WARNINGS

DETECTABLE WARNING SURFACE DETAILS

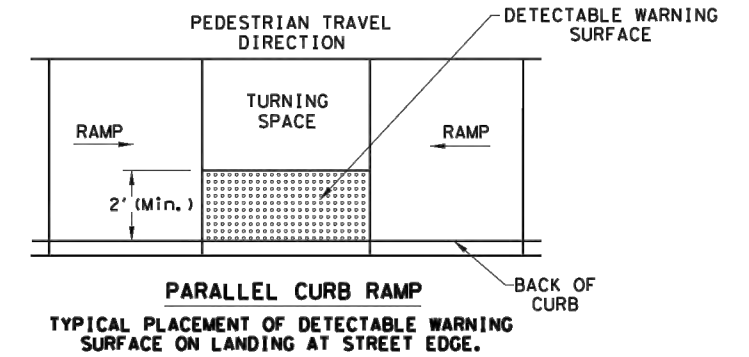

PARALLEL CURB RAMP
TYPICAL PLACEMENT OF DETECTABLE WARNING SURFACE ON LANDING AT STREET EDGE.

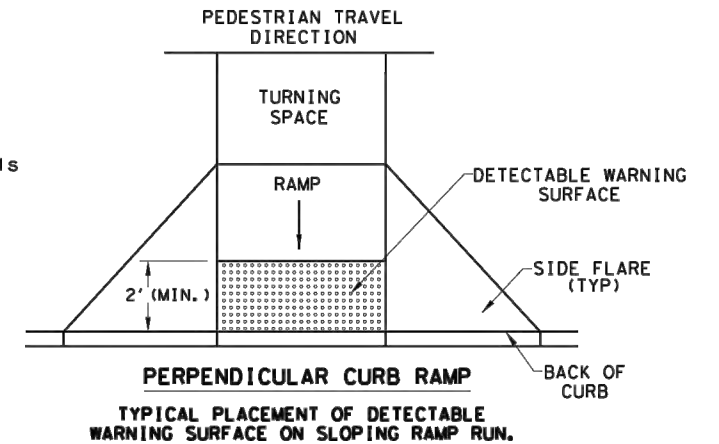

PERPENDICULAR CURB RAMP
TYPICAL PLACEMENT OF DETECTABLE WARNING SURFACE ON SLOPING RAMP RUN.

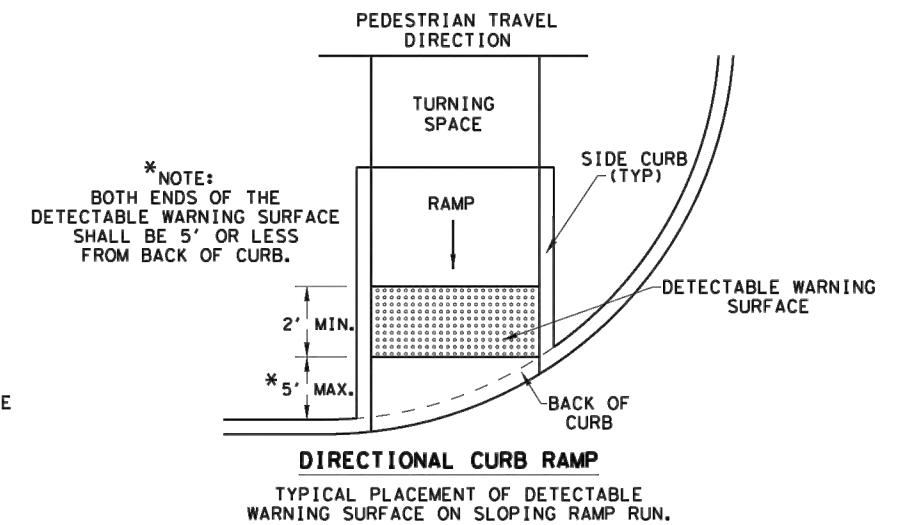

DIRECTIONAL CURB RAMP
TYPICAL PLACEMENT OF DETECTABLE WARNING SURFACE ON SLOPING RAMP RUN.

SHEET 2 OF 4



PEDESTRIAN FACILITIES

CURB RAMPS

PED-18

FILE: ped18	DN: TxDOT	DW: VP	CK: KM	CK: PK & JG
© TxDOT: MARCH, 2002	CONT	SECT	JOB	HIGHWAY
REVISIONS	0902	90	082	VA
REVISED 08, 2009	DIST	COUNTY	SHEET NO.	
REVISED 06, 2012	FTW	TARRANT	260	
REVISED 01, 2018				

DATE: FILE:

DISCLAIMER: The use of this standard is governed by the "Texas Engineering Practice Act". No warranty of any kind is made by TxDOT for any purpose whatsoever. TxDOT assumes no responsibility for the conversion of this standard to other formats or for incorrect results or damages resulting from its use.

SIDEWALK TREATMENT AT DRIVEWAYS

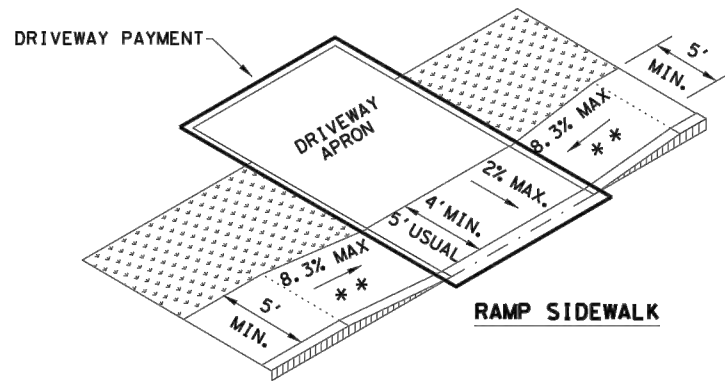
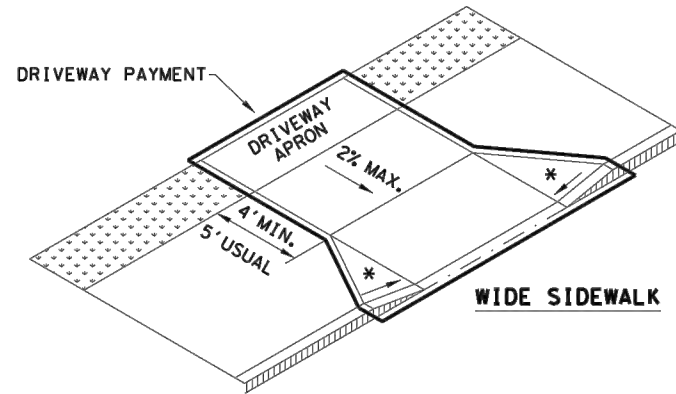
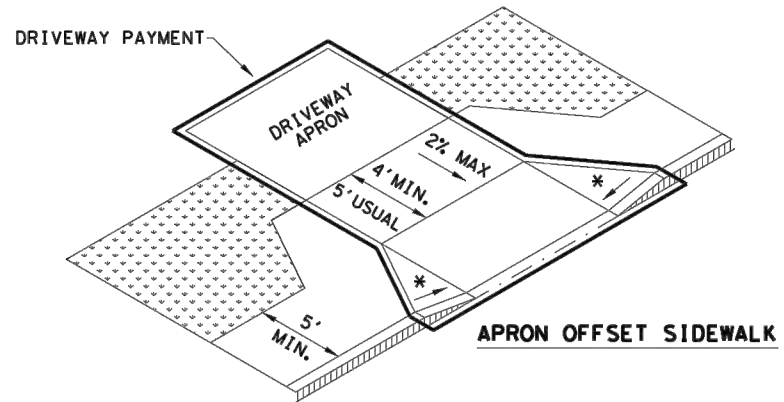
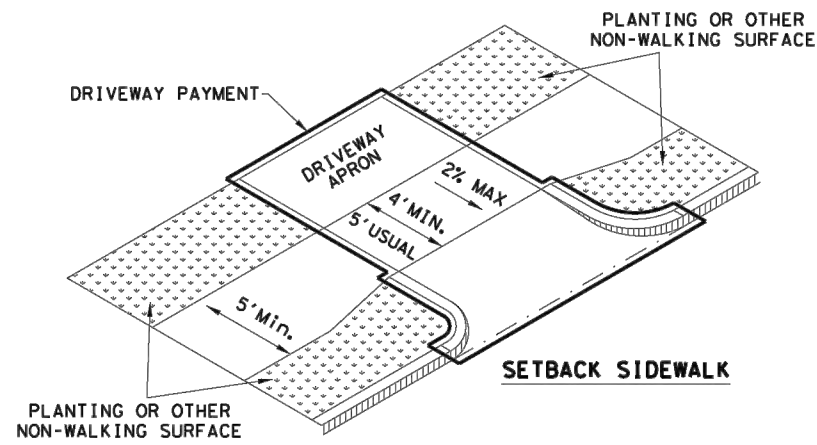

NOTES:
 * WHERE DRIVEWAYS CROSS THE PEDESTRIAN ROUTE, SIDES SHALL BE FLARED AT 10% MAX SLOPE.
 * * IF CURB HEIGHT IS GREATER THAN 6 INCHES, USE GRADE LESS THAN OR EQUAL TO 5%. HANDRAIL AND DETECTABLE WARNING ARE NOT REQUIRED.

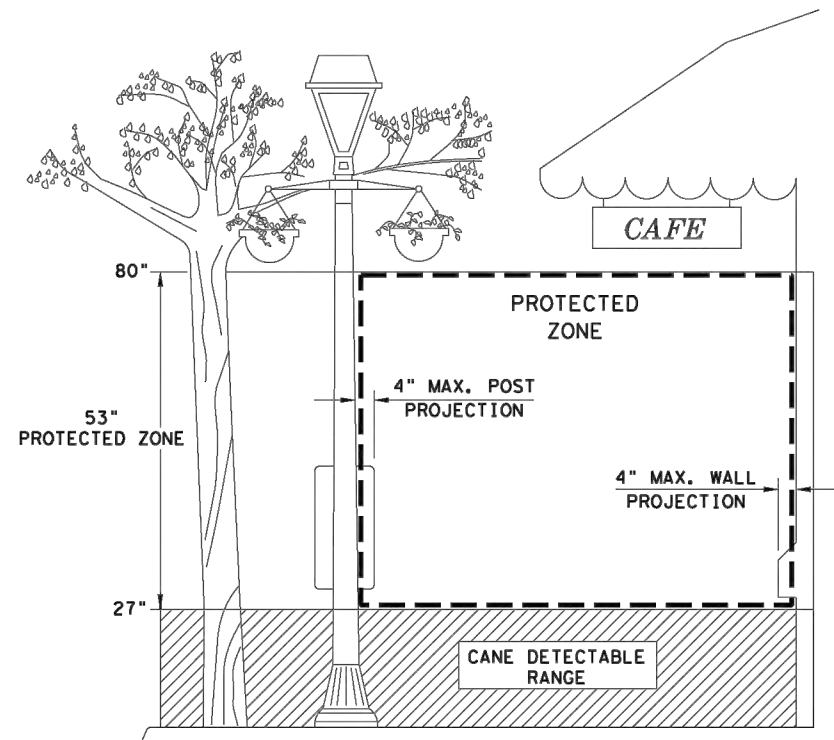

NOTE: IN PEDESTRIAN CIRCULATION AREA, MAXIMUM 4" PROJECTION FOR POST OR WALL MOUNTED OBJECTS BETWEEN 27" AND 80" ABOVE THE SURFACE.

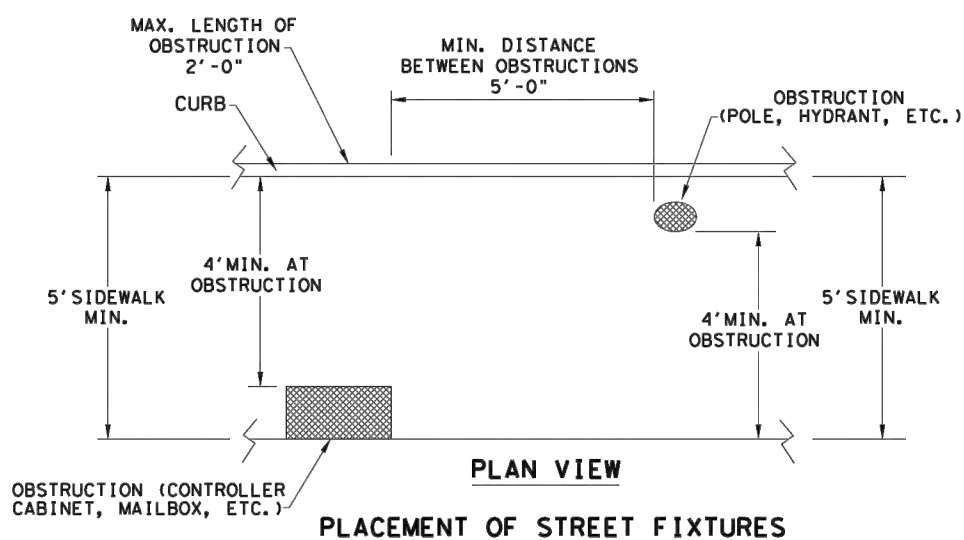
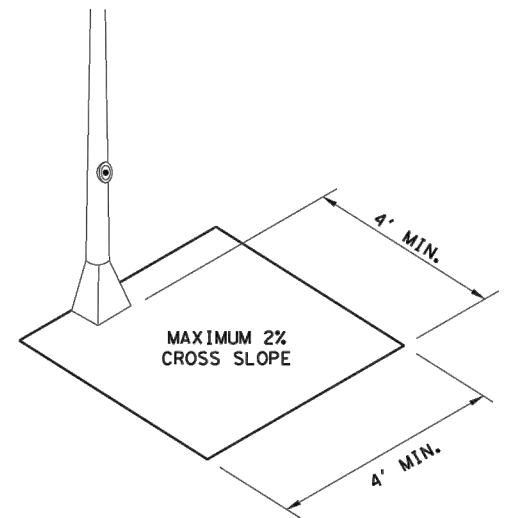

NOTE: ITEMS NOT INTENDED FOR PUBLIC USE. MINIMUM 4' X 4' CLEAR GROUND SPACE REQUIRED AT PUBLIC USE FIXTURES.

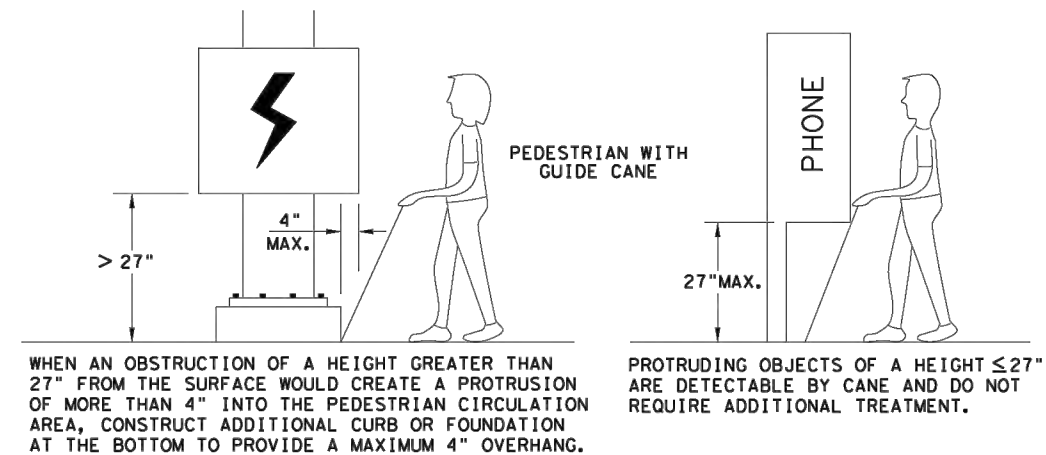

WHEN AN OBSTRUCTION OF A HEIGHT GREATER THAN 27" FROM THE SURFACE WOULD CREATE A PROTRUSION OF MORE THAN 4" INTO THE PEDESTRIAN CIRCULATION AREA, CONSTRUCT ADDITIONAL CURB OR FOUNDATION AT THE BOTTOM TO PROVIDE A MAXIMUM 4" OVERHANG.

PROTRUDING OBJECTS OF A HEIGHT ≤ 27" ARE DETECTABLE BY CANE AND DO NOT REQUIRE ADDITIONAL TREATMENT.

SHEET 3 OF 4

Texas Department of Transportation
 Design Division Standard

PEDESTRIAN FACILITIES
CURB RAMPS
PED-18

FILE: ped18	DN: TxDOT	DW: VP	CK: KM	CK: PK & JG
© TxDOT: MARCH, 2002	CONT	SECT	JOB	HIGHWAY
REVISIONS	0902	90	082	VA
REVISED 08, 2009	DIST	COUNTY	SHEET NO.	
REVISED 06, 2012	FTW	TARRANT	261	
REVISED 01, 2018				

DATE:
 FILE:

DISCLAIMER: The use of this standard is governed by the "Texas Engineering Practice Act". No warranty of any kind is made by TxDOT for any purpose whatsoever. TxDOT assumes no responsibility for the conversion of this standard to other formats or for incorrect results or damages resulting from its use.

TYPICAL CROSSING LAYOUTS
SEE SHEET 1 OF 4 FOR DETAILS AND DIMENSIONS

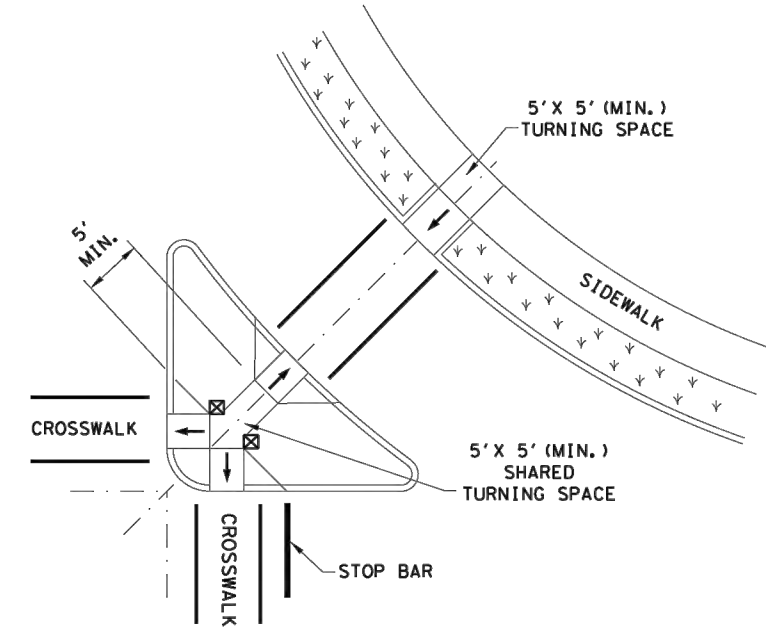
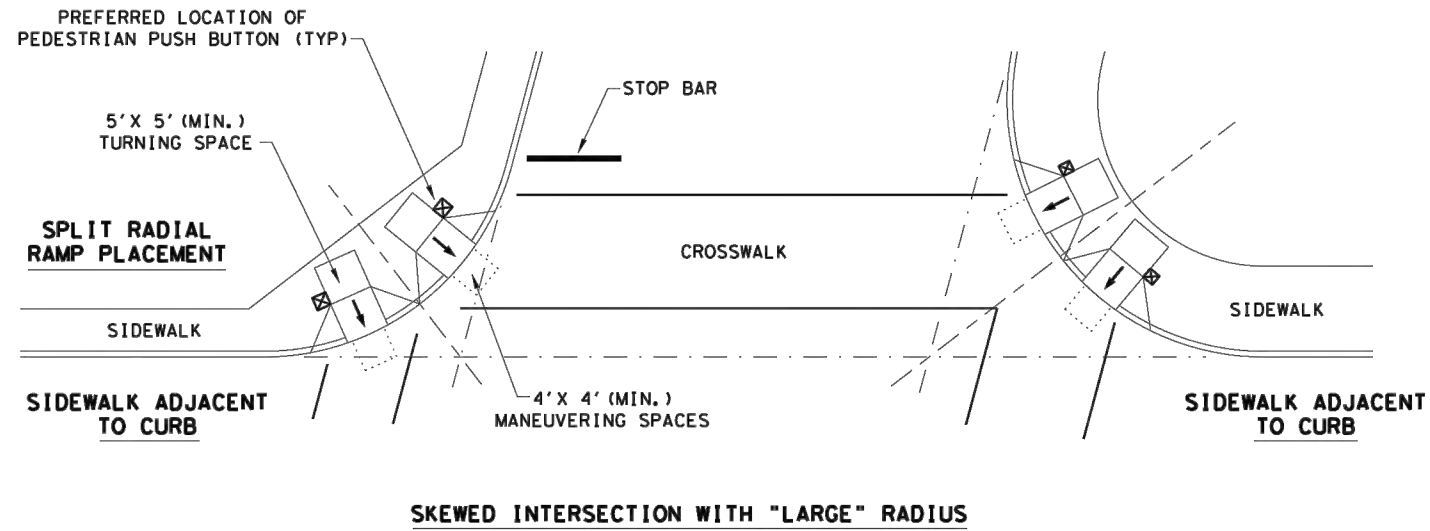

AT INTERSECTION
W/FREE RIGHT TURN & ISLAND

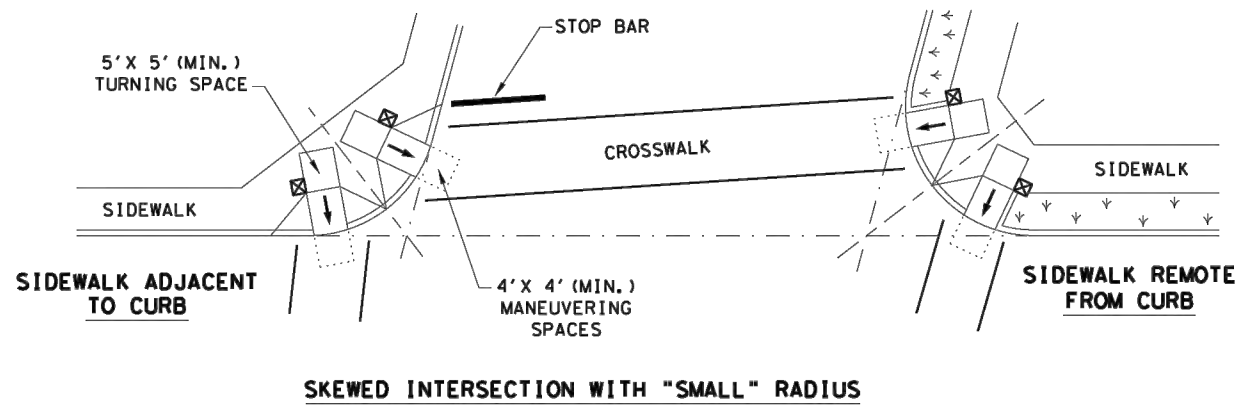

SKewed INTERSECTION WITH "SMALL" RADIUS

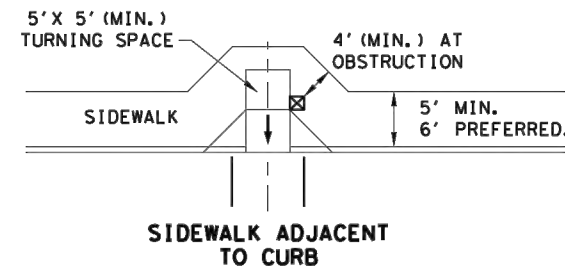

MID-BLOCK PLACEMENT
PERPENDICULAR RAMPS

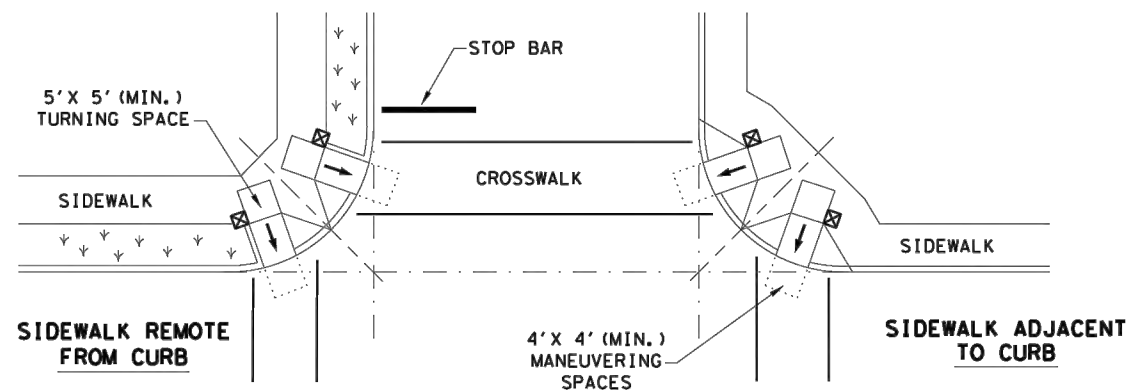
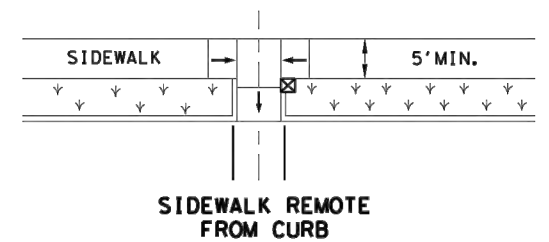

NORMAL INTERSECTION WITH "SMALL" RADIUS

LEGEND:

SHOWS DOWNWARD SLOPE. →

DENOTES PREFERRED LOCATION OF PEDESTRIAN PUSH BUTTON (IF APPLICABLE). ☒

DENOTES PLANTING OR NON-WALKING SURFACE NOT PART OF PEDESTRIAN CIRCULATION PATH. ↙ ↘ ↗ ↖

SHEET 4 OF 4



Design
Division
Standard

PEDESTRIAN FACILITIES
CURB RAMPS

PED-18

FILE: ped18	DN: TxDOT	DW: VP	CK: KM	CK: PK & JG
© TxDOT: MARCH, 2002	CONT	SECT	JOB	HIGHWAY
REVISIONS	0902	90	082	VA
REVISED 08, 2009	DIST	COUNTY	SHEET NO.	
REVISED 06, 2012	FTW	TARRANT	262	
REVISED 01, 2018				

DATE:
FILE:

DISCLAIMER: The use of this standard is governed by the "Texas Engineering Practice Act". No warranty of any kind is made by TxDOT for any purpose whatsoever. TxDOT assumes no responsibility for the conversion of this standard to other formats or for incorrect results or damages resulting from its use.

DATE:
FILE:

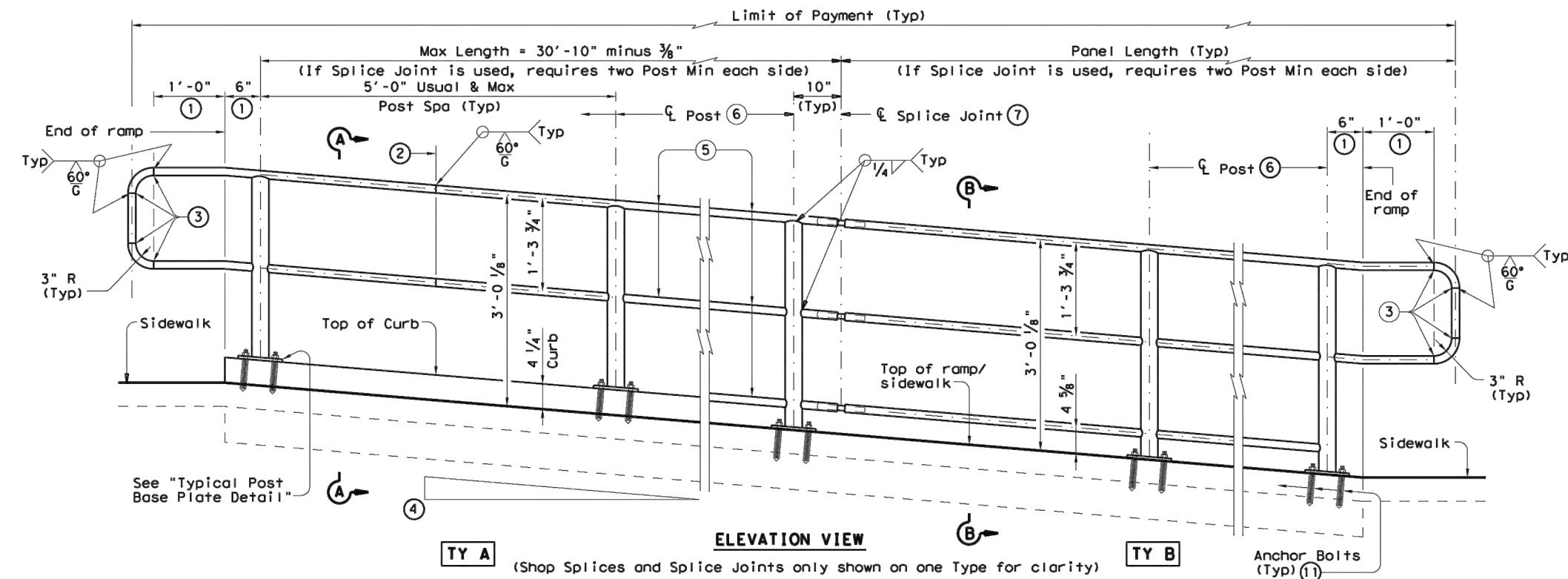

TY A (Shop Splices and Splice Joints only shown on one Type for clarity) **TY B** Anchor Bolts (Typ) (11)

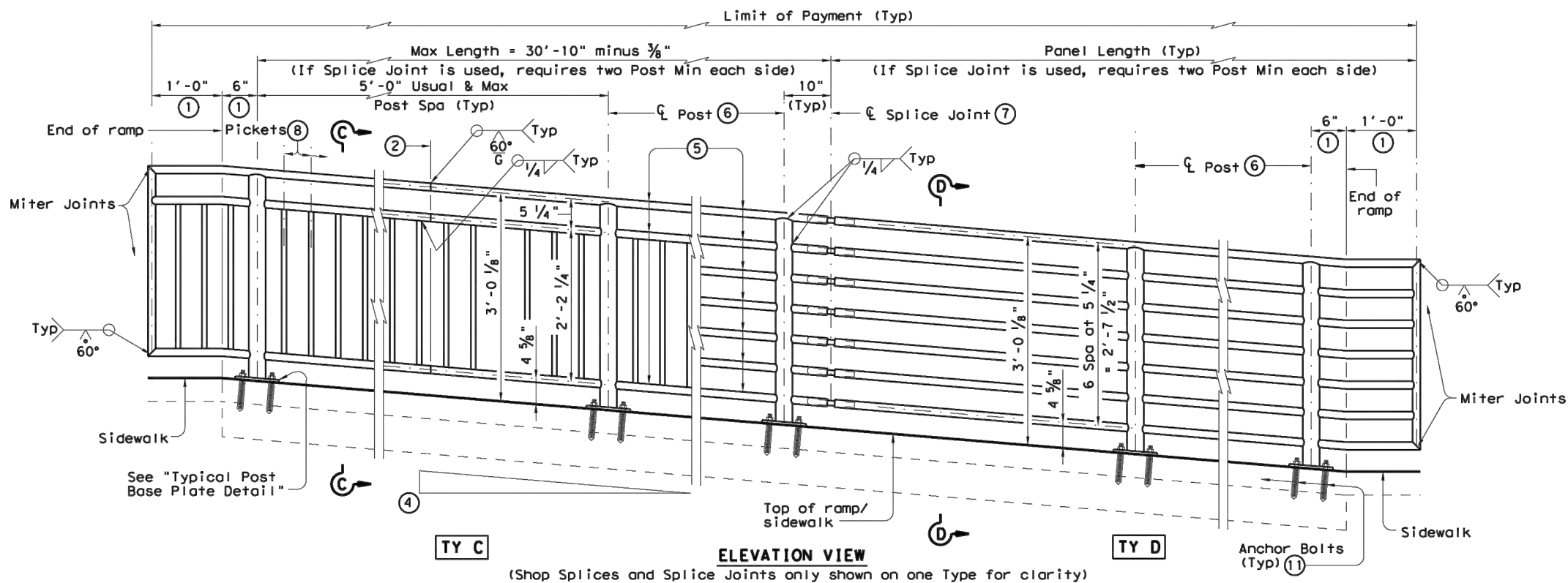

TY C (Shop Splices and Splice Joints only shown on one Type for clarity) **TY D** Anchor Bolts (Typ) (11)

RECOMMENDED USAGE (9) (10)	
Dropoff Height/Condition	Recommended Rail Options
< 30" dropoff	TY A, TY B, TY C, or TY D
≥ 30" dropoff, or along Bike Path	TY E or TY F

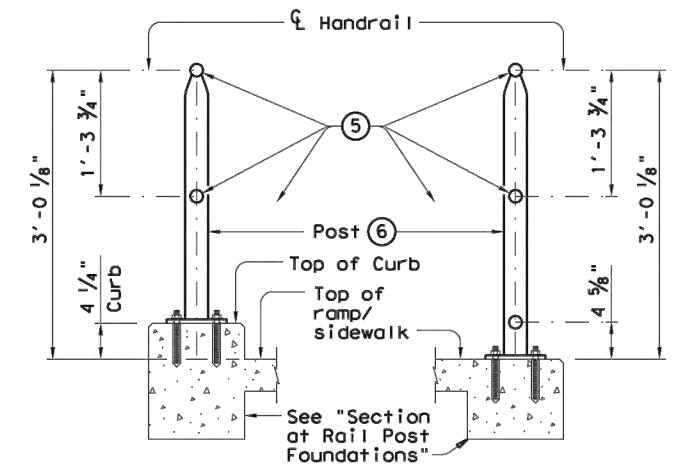

SECTION A-A (Showing Handrail TY A) **SECTION B-B** (Showing Handrail TY B)

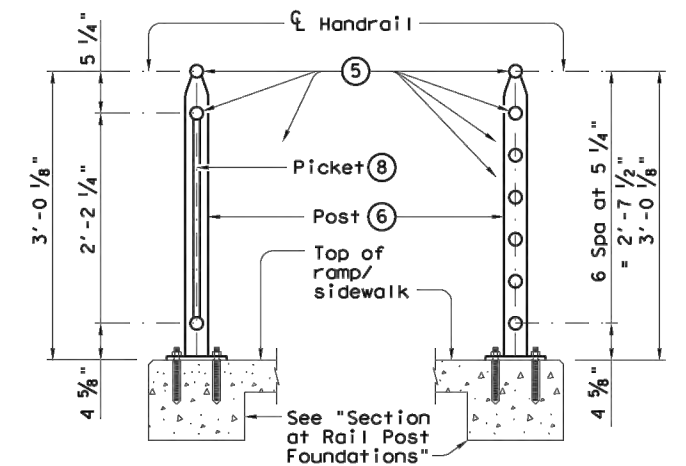

SECTION C-C (Showing Handrail TY C) **SECTION D-D** (Showing Handrail TY D)

SHEET 1 OF 3

- ① Parallel to ground.
- ② One shop splice per panel is permitted with minimum 85 percent penetration. The weld may be square groove or single vee groove. Grind smooth.
- ③ Shop splice is permitted with minimum 85 percent penetration. The weld may be square groove or single vee groove. Grind smooth.
- ④ See Ramp Details located elsewhere in plans for ramp slope and dimensions. Maximum ramp slope will not exceed 8.3 percent. Level landing required for each 30" rise if grade exceeds 5 percent.
- ⑤ 1 1/2" Dia. Standard Pipe (1.900" O.D., 0.145" wall thickness). Parallel to ramp / sidewalk. Provide holes as needed in 1 1/2" Dia. pipe for galvanizing drainage and venting.
- ⑥ 2 1/2" Dia. Standard Pipe (2.875" O.D., 0.203" wall thickness). See "Post Mount Detail" for crimping and trimming post to fit Dia. of top rail. Provide holes as needed in post for galvanizing drainage and venting. Plumb all posts.
- ⑦ See "Handrail Fabrication Details" for Splice Joints.
- ⑧ 1/2" Dia. Round Bar equal spacing at 4 1/2" Max. Plumb all pickets.
- ⑨ When needed for accessibility (grade > 5 percent) or as needed for pedestrian safety.
- ⑩ Not to be used on bridges.
- ⑪ See "General Notes" for anchor bolt information.

		Design Division Standard	
<h2>PEDESTRIAN HANDRAIL DETAILS</h2> <h3>PRD-13</h3>			
FILE: prd13.dgn	DN: TxDOT	CK: AM	DW: JTR
© TxDOT December 2006	CONT	SECT	JOB
REVISIONS	0902	90	082
REVISED MAY, 2013 (VP)	DIST	COUNTY	SHEET NO.
	FTW	TARRANT	263

DISCLAIMER: The use of this standard is governed by the "Texas Engineering Practice Act". No warranty of any kind is made by TxDOT for any purpose whatsoever. TxDOT assumes no responsibility for the conversion of this standard to other formats or for incorrect results or damages resulting from its use.

DATE:
FILE:

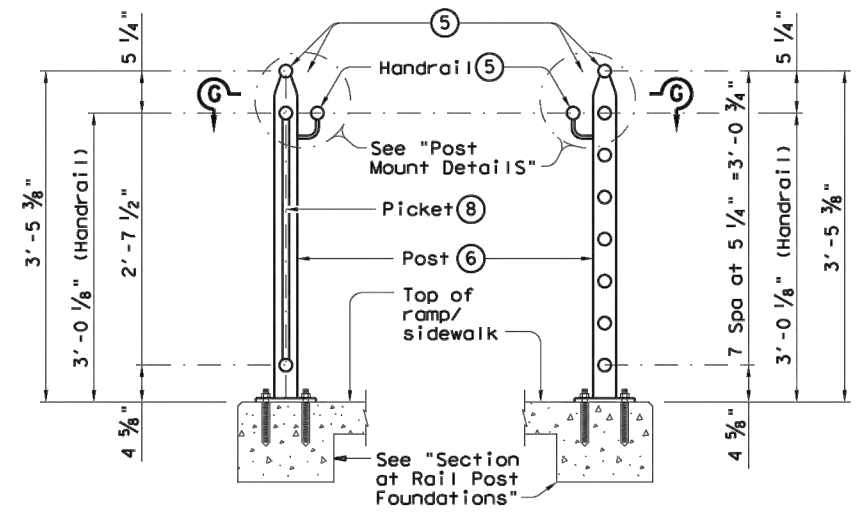
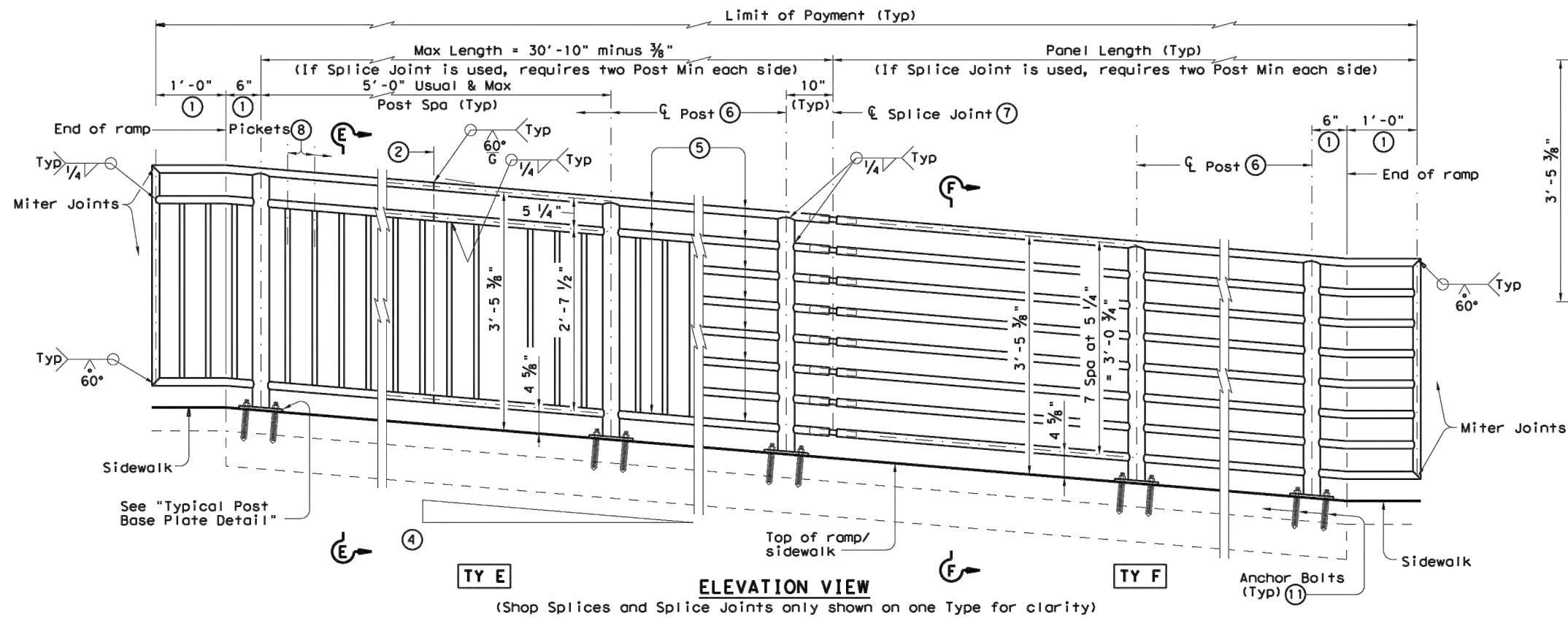

SECTION E-E
(Showing Handrail TY E)

SECTION F-F
(Showing Handrail TY F)

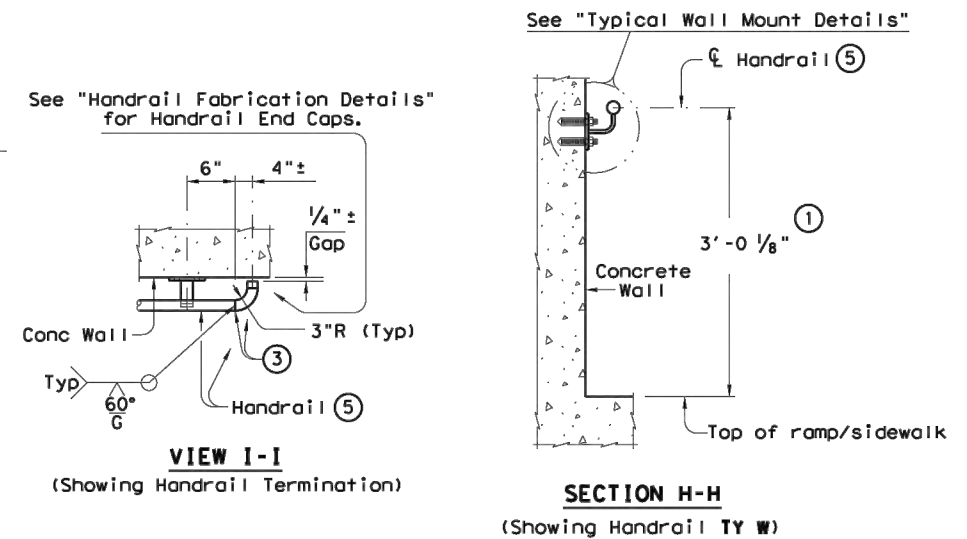
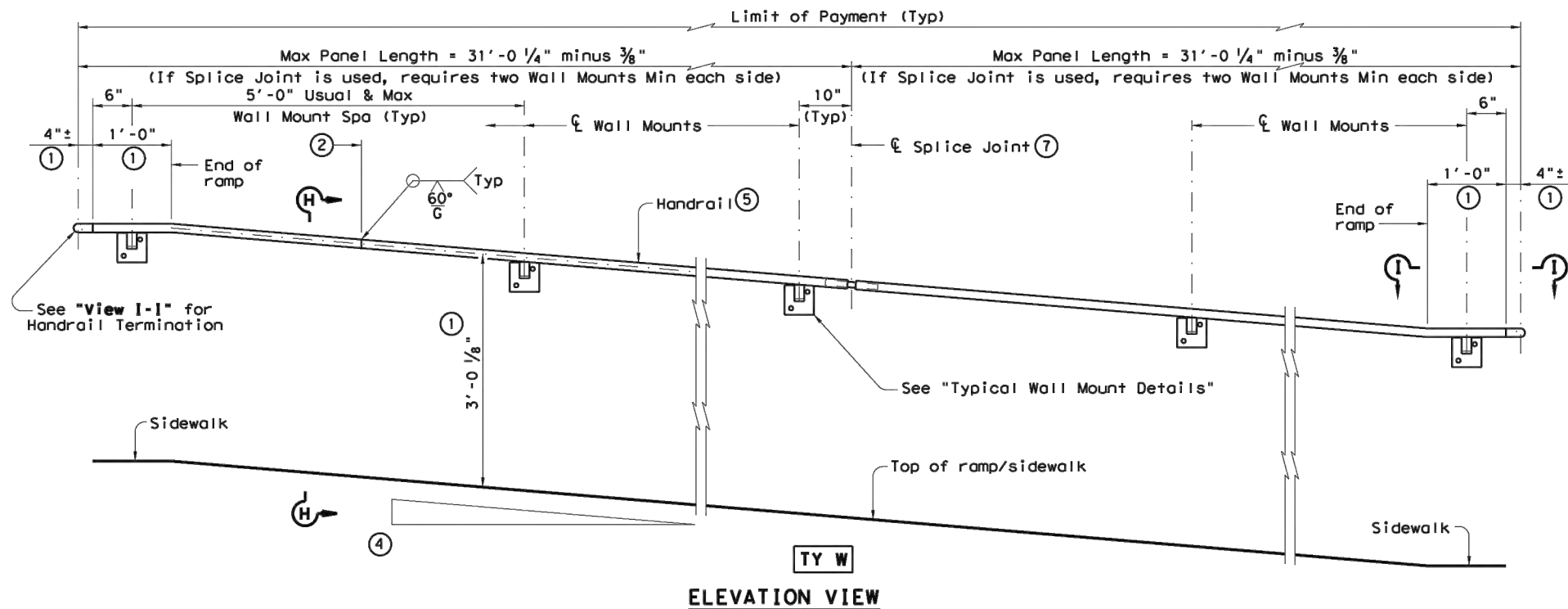
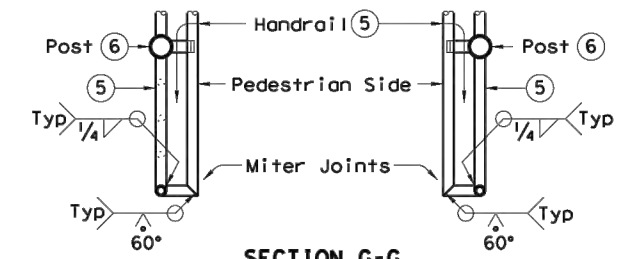

- ① Parallel to ground.
- ② One shop splice per panel is permitted with minimum 85 percent penetration. The weld may be square groove or single vee groove. Grind smooth.
- ③ Shop splice is permitted with minimum 85 percent penetration. The weld may be square groove or single vee groove. Grind smooth.
- ④ See Ramp Details located elsewhere in plans for ramp slope and dimensions. Maximum ramp slope will not exceed 8.3 percent. Level landing required for each 30" rise if grade exceeds 5 percent.
- ⑤ 1 1/2" Dia. Standard Pipe (1.900" O.D., 0.145" wall thickness). Parallel to ramp / sidewalk. Provide holes as needed in 1 1/2" Dia. pipe for galvanizing drainage and venting.
- ⑥ 2 1/2" Dia. Standard Pipe (2.875" O.D., 0.203" wall thickness). See "Post Mount Detail" for crimping and trimming post to fit Dia. of top rail. Provide holes as needed in post for galvanizing drainage and venting. Plumb all posts.
- ⑦ See "Handrail Fabrication Details" for Splice Joints.
- ⑧ 5/8" Dia. Round Bar equal spacing at 4 1/2" Max. Plumb all pickets.
- ⑪ See "General Notes" for anchor bolt information.

SHEET 2 OF 3



**PEDESTRIAN HANDRAIL
DETAILS
PRD-13**

FILE: prd13.dgn	DN: TxDOT	CK: AM	DW: JTR	CK: CGL
© TxDOT December 2006	CONT	SECT	JOB	HIGHWAY
REVISIONS	0902	90	082	VA
REVISED MAY, 2013 (VP)	DIST	COUNTY	SHEET NO.	
	FTW	TARRANT	264	

DISCLAIMER: The use of this standard is governed by the "Texas Engineering Practice Act". No warranty of any kind is made by TxDOT for any purpose whatsoever. TxDOT assumes no responsibility for the conversion of this standard to other formats or for incorrect results or damages resulting from its use.

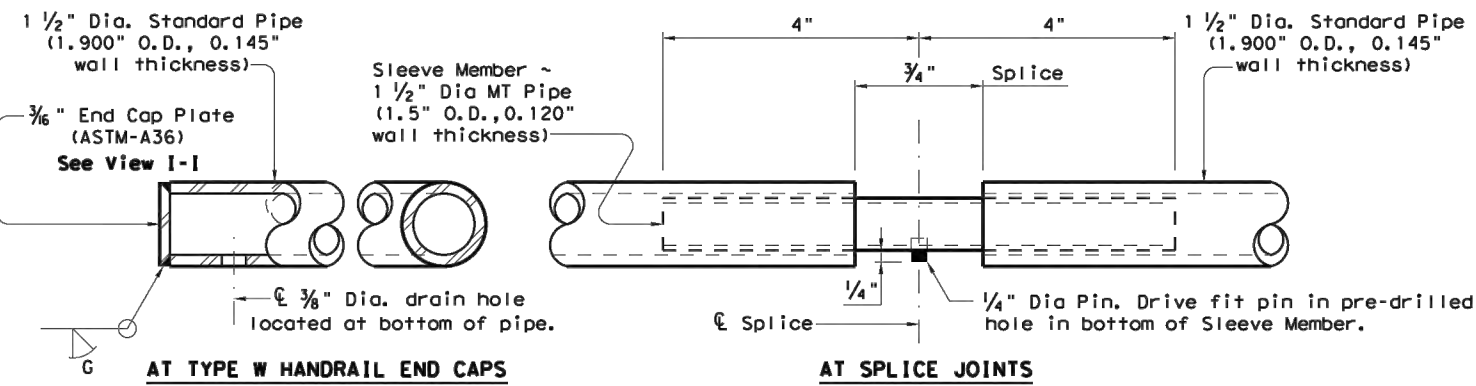

HANDRAIL FABRICATION DETAILS

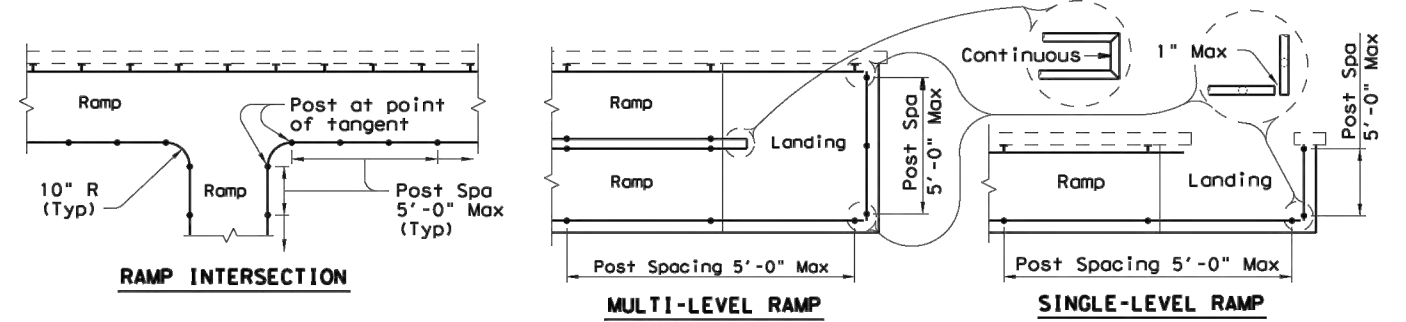

PLAN SHOWING RAIL AT RAMP CONDITIONS

GENERAL NOTES

Designed according to ADAAG, Texas Accessibility Standards, Uniform Building Code, and AASHTO LRFD Specifications.

Handrail anchorage details shown on this standard may require modification for select structure types. See appropriate details elsewhere in plans for these modifications.

Pipe will conform to ASTM-A53 Grade B or A500 Grade B. Steel plates and steel bars will conform to ASTM-A36. Mechanical tubing (MT) will conform to ASTM A513 Grade 1015 or higher. Galvanize all steel components except reinforcing steel unless noted otherwise.

Concrete for foundations will be in accordance with Item 531 "Sidewalks". All reinforcing steel must be Grade 60. Bar laps, where required, will be as follows: Uncoated ~ #4 = 1'-5" Epoxy coated ~ #4 = 2'-1"

When the plans require painted steel, follow the requirements for painting galvanized steel in Item 446, "Cleaning and Painting Steel". Sleeve Members will receive galvanization and only get field painted after installation unless directed otherwise by Engineer.

Epoxy Anchor bolts for wall mount and post base plate will be 5/8" Dia. ASTM A36 threaded rods with one hex nut and one hardened steel washer at each bolt. 3/8" Dia. threaded rod embedment depth for wall mounts is 3 1/2" and embedment depth for post base plate is 5".

Embed threaded rods into concrete with a Type III (Class C) epoxy meeting the requirements of DMS-6100, "Epoxyes and Adhesives". Mix and dispense adhesive with the manufacturer's static mixing nozzle/dual cartridge system. Core drill holes (percussion drilling not permitted).

At the contractor's option the post base plate anchor bolts may be cast with the Ramp/Sidewalk (See Cast-in-Place Anchor Bolt Options).

Optional cast-in-place anchor bolts will be 5/8" Dia ASTM A307 Grade A bolts (or A36 threaded rods with one tack welded hex nut each) with one hex nut and one hardened steel washer at each bolt. Embedment depth of cast-in-place bolt will be 8" for post base plate.

Handrails and any wall or other surface adjacent to them will be free of any sharp or abrasive elements.

Submit shop drawings to the Engineer unless otherwise noted. For curved handrail applications, fabricate the handrail to the curve if radius is less than 600 ft. Shop drawings are required when rail is fabricated to the curve.

For all handrails, erection drawings will be submitted to the Engineer for approval to ensure proper installation.

Drawings will show handrail mount locations with bolts setting, spacing, ramp slope, and/or splice joint locations, and handrail lengths with identification showing where each handrail goes on the layout.

Payment for concrete sidewalks or curb ramps will be paid for in accordance with Item 531 "Sidewalks".

Payment for all items shown is to be included in unit price bid in accordance with Item 450 "Railing" of the type specified.

All exposed edges will be rounded or chamfered to approximately 1/8" by grinding.

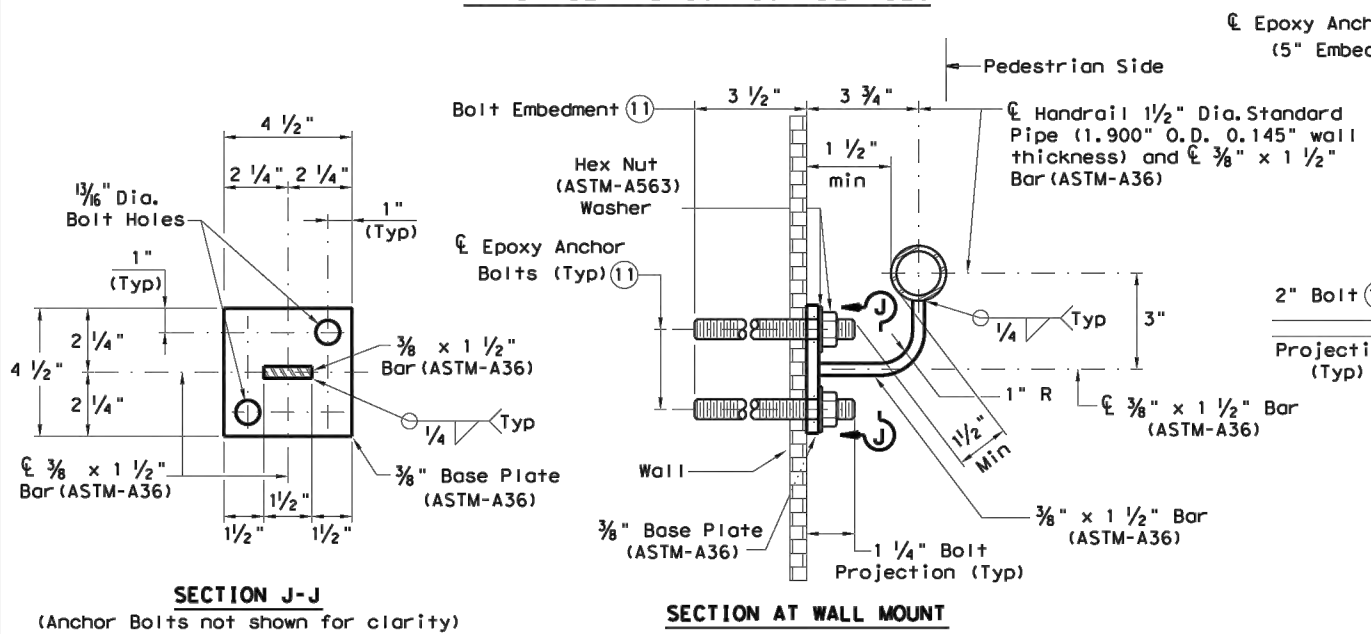

TYPICAL WALL MOUNT DETAILS

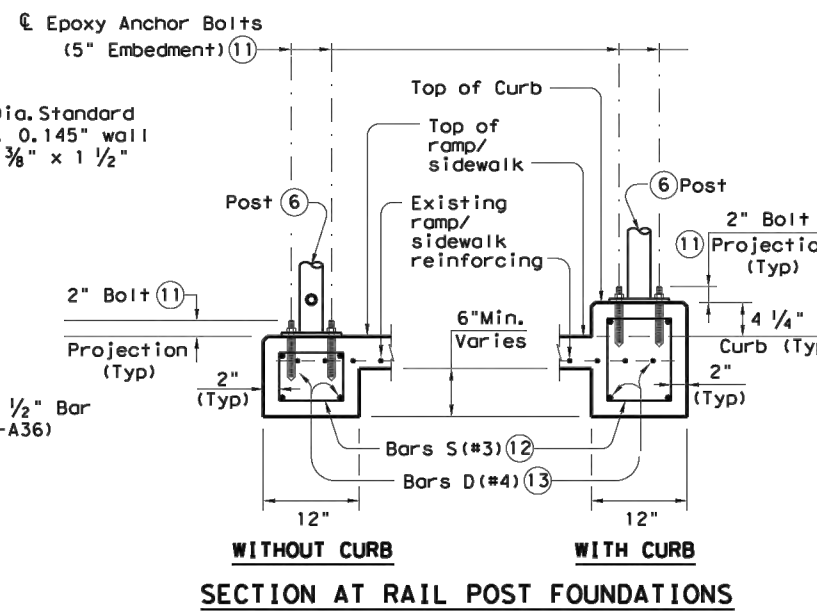

SECTION AT RAIL POST FOUNDATIONS

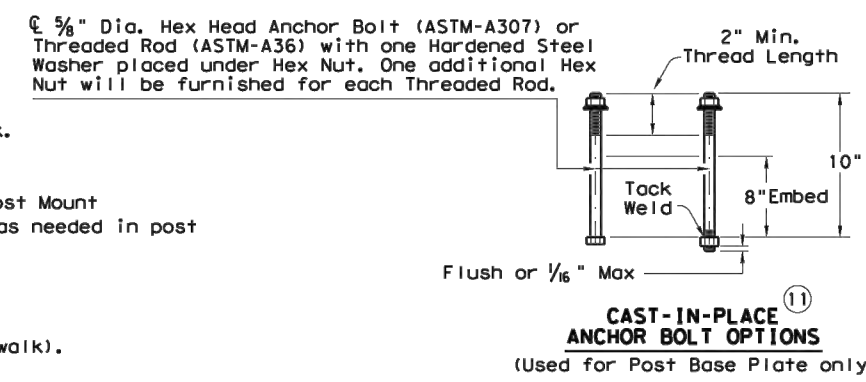

- (5) 1 1/2" Dia. Standard Pipe (1.900" O.D., 0.145" wall thickness). Parallel to ramp/sidewalk. Provide holes as needed in 1 1/2" Dia. pipe for galvanizing drainage and venting.
- (6) 2 1/2" Dia. Standard Pipe (2.875" O.D., 0.203" wall thickness). Plumb all posts. See "Post Mount Detail" for crimping and trimming post to fit the diameter of top rail. Provide holes as needed in post for galvanizing drainage and venting.
- (11) See "General Notes" for anchor bolt information.
- (12) Bars S (#3) spaced at 12" Max (Spaced 3" from outside edge of overall length of Ramp/Sidewalk).
- (13) Provide 1 1/2" end cover to Bars D (#4) from outside edge of overall length of Ramp/Sidewalk.

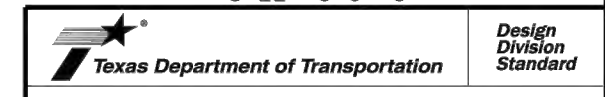
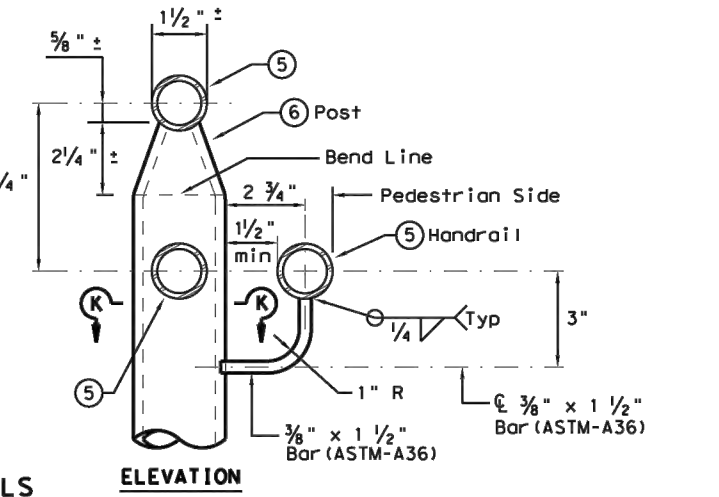
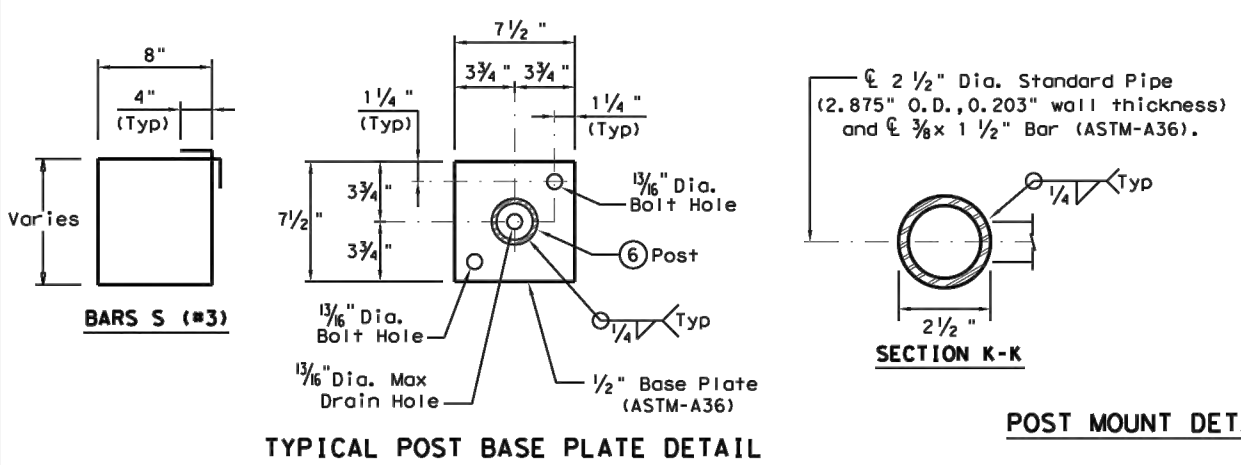

PEDESTRIAN HANDRAIL DETAILS
PRD-13

FILE: prd13.dgn	DN: TxDOT	CK: AM	DW: JTR	CK: CGL
© TxDOT December 2006	CONT	SECT	JOB	HIGHWAY
REVISIONS	0902	90	082	VA
REVISED MAY, 2013 (VP)	DIST	COUNTY	SHEET NO.	
	FTW	TARRANT	265	

DATE: FILE:

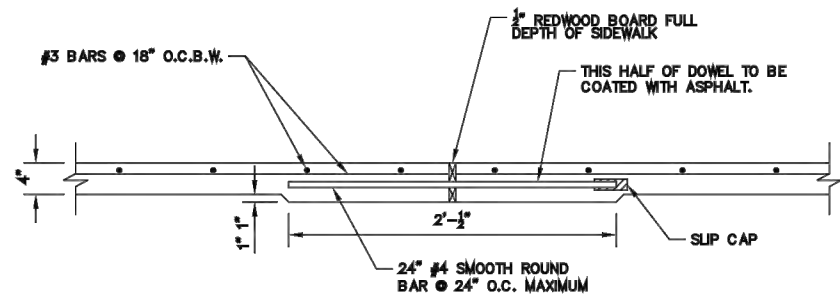

EXPANSION JOINT DETAIL

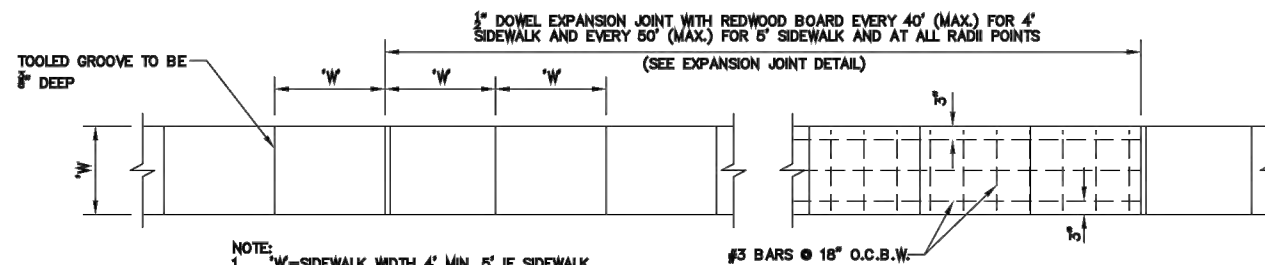

PLAN
REINFORCED CONCRETE SIDEWALK

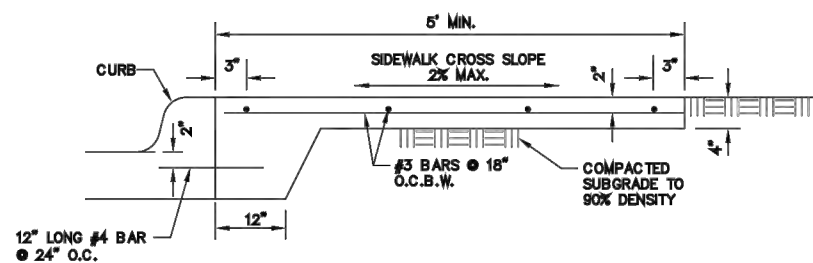

SECTION VIEW
SIDEWALK ADJACENT TO CURB

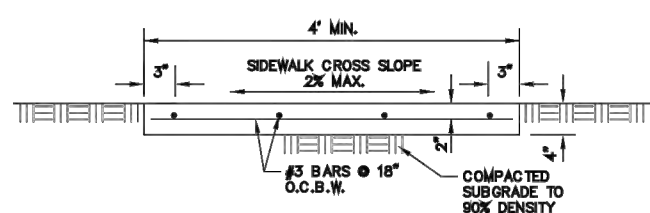

SECTION VIEW
SIDEWALK

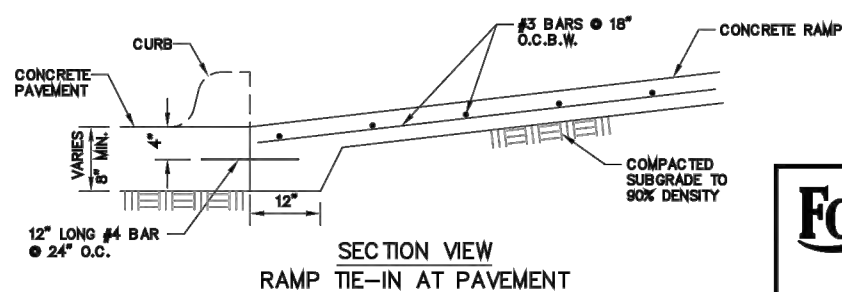

SECTION VIEW
RAMP TIE-IN AT PAVEMENT

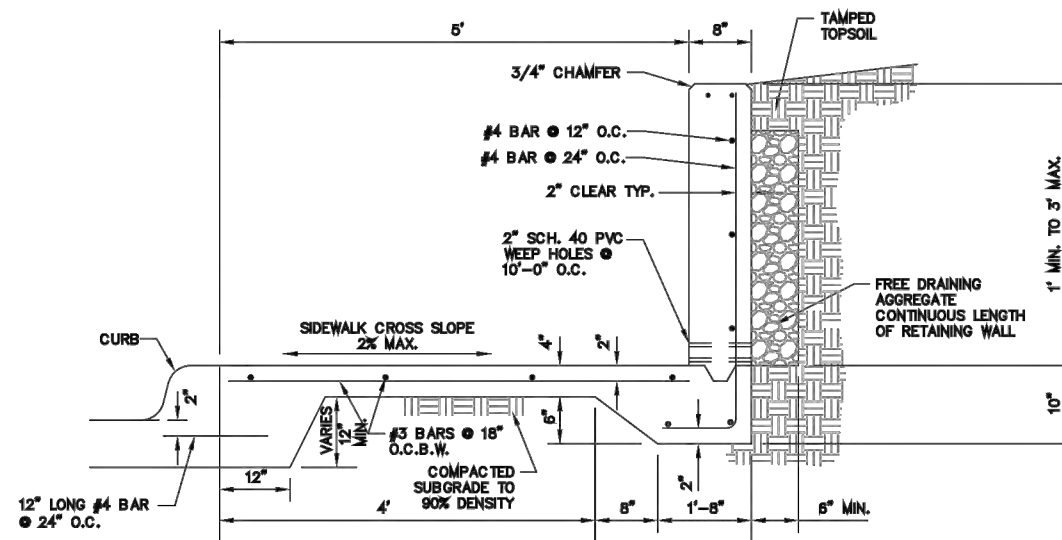

SECTION VIEW
SIDEWALK ADJACENT TO CURB WITH RETAINING WALL



Joshua Wright
PROJECT ENGINEER
6/7/2021
DATE

DATE	BY	REV	REVISION

DUNAWAY 550 Bailey Avenue
Suite 400
Fort Worth, TX 76107
817-335-1121
(TX REG #1114)



PROJ NO. 101264

Texas Department of Transportation
© 2021

2018 SAFE ROUTES TO SCHOOL IMPROVEMENTS

CFW STANDARD DETAIL D546



CITY OF FORT WORTH, TEXAS
SIDEWALK DETAILS

REVISED: 01-06-2014

32 13 20-D546

FED. RD. DIV. NO.	STATE	PROJECT NO.	HIGHWAY NO.		
6	TEXAS	STP 2021(929)TP	VA		
STATE DISTRICT	COUNTY	CONTROL NO.	SECTION NO.	JOB NO.	SHEET NO.
FTW	TARRANT	0902	90	082	266