



TRANSPORTATION ENGINEERING MANUAL

FORT WORTH®



TRANSPORTATION AND
PUBLIC WORKS DEPARTMENT

Contents

CHAPTER 1 - INTRODUCTION AND CONTEXT	1-2
1.1 What is the Transportation Engineering Manual?	1-2
1.2 Purpose of Manual	1-3
1.3 Existing Local and National Best Practices.....	1-3
1.3.1 National Standards and Guidelines that Govern the Design of Streets	1-4
CHAPTER 2 - THOROUGHFARE FRAMEWORK	2-2
2.1 Street Typology	2-2
2.1.1 Street Type	2-2
2.2 Cross Sections	2-4
2.2.1 Overview.....	2-4
2.3 Street Pattern and Connectivity	2-7
2.3.1 Street and Block Arrangements.....	2-7
2.3.2 Street Length	2-7
CHAPTER 3 - STREET DESIGN	3-4
3.1 Introduction	3-4
3.2 Design Controls.....	3-10
3.2.1 Design Speed/Target Speed	3-10
3.2.2 Design Volume.....	3-10
3.2.3 Stopping Sight Distance	3-12
3.2.4 Horizontal Sight Distance	3-12
3.3 Design Elements	3-14
3.3.1 Horizontal Alignment	3-14
3.3.2 Vertical Alignment	3-15
3.3.3 Pavement Cross and Side Slopes.....	3-19
3.3.4 Pavement Transition	3-19
3.3.5 Signage and Pavement Markings.....	3-20
3.4 Other Elements	3-21
3.4.1 Roadway Drainage.....	3-21
3.4.2 Public Right-of-Way Visibility Requirements.....	3-21
3.4.3 Street Lighting.....	3-21
3.4.4 Medians	3-24
3.4.5 On-Street Parking	3-26
3.4.6 Access Management.....	3-29
3.4.7 Complete Street Components	3-32
3.4.8 Right-Sized Roadways.....	3-32
3.4.9 Established Thoroughfares	3-34
3.4.10 Air Rights	3-35
3.5 Design Criteria for other Road Classifications.....	3-35
3.5.1 Alleys and Alleyway Turnouts.....	3-35
3.5.2 Driveways	3-36
3.5.3 Dead-End Streets and Culs-De-Sac.....	3-38

CHAPTER 4 - BICYCLE FACILITIES..... 4-5

- 4.1 Introduction 4-5
- 4.2 Active Transportation Plan..... 4-5
- 4.3 Planning for a Range of Bikeway Users..... 4-5
 - 4.3.1 Designing for Interested but Concerned and Experienced and Confident Bicyclists..... 4-5
 - 4.3.2 Impact of Roadway Characteristics on Bicycle Facility Selection..... 4-7
- 4.4 Bicycle Network..... 4-11
- 4.5 Bikeway Design Guidelines 4-12
 - 4.5.1 Typical Application 4-12
 - 4.5.2 Shared-Use Paths/Sidepaths 4-12
 - 4.5.3 Separated Bicycle Lanes..... 4-13
 - 4.5.4 Signing and Marking for Separated Bicycle Lanes 4-15
 - 4.5.5 Separated Bicycle Lane Design Parameters 4-17
 - 4.5.6 Separated Bicycle Lane Design Examples 4-19
 - 4.5.7 Buffered Bicycle Lanes..... 4-21
 - 4.5.8 Contra-Flow Bicycle Lane 4-22
 - 4.5.9 Bicycle Lanes..... 4-24
 - 4.5.10 Advisory Bicycle Lanes 4-27
 - 4.5.11 Shared Lane Markings 4-29
 - 4.5.12 Transitions Between Bicycle Facilities..... 4-30
 - 4.5.13 Transition from One-Way Separated Bicycle Lane to Conventional Bicycle Lane on Same Street..... 4-33
 - 4.5.14 Transition from Two-Way Separated Bicycle Lane to One-Way Separated Bicycle Lane on Intersecting Street..... 4-35
 - 4.5.15 Transition between One-Way Separated Bicycle Lanes at an Intersection 4-37
- 4.6 Enhancements and Supporting Treatments for Bicycle Facilities 4-39
 - 4.6.1 Bicycle Boulevard Treatments..... 4-39
 - 4.6.2 Roundabout Treatments..... 4-40
 - 4.6.3 Crossing Treatments..... 4-40
 - 4.6.4 Bicycle Signals, Detection, Actuation 4-41
 - 4.6.5 Bicycle Boxes..... 4-43
 - 4.6.6 Two-Stage Turn Queue Box..... 4-45
 - 4.6.7 Mixing Zones..... 4-47
 - 4.6.8 Through Bicycle Lane Approach 4-49
 - 4.6.9 Conflict Area Marking 4-50
 - 4.6.10 Mid-Block Shared-Use Path Crossings 4-51
 - 4.6.11 Separated Bicycle Lanes at Intersections (Protected Intersections) 4-53
 - 4.6.12 Separated Bicycle Lanes at Roundabouts..... 4-55
 - 4.6.13 Separated Bicycle Lanes at Driveways 4-56
 - 4.6.14 Bridge Design 4-57
- 4.7 Implementation of Bikeway Network..... 4-59
 - 4.7.1 Separated Bicycle Lane Maintenance 4-60
 - 4.7.2 Bicycle Parking..... 4-62
 - 4.7.3 On-Street Bicycle Parking 4-63
 - 4.7.4 Off-Street Bicycle Parking 4-64
- 4.8 References for Bicycle Facility Design..... 4-65

CHAPTER 5 - PEDESTRIAN ZONE	5-3
5.1 Introduction	5-3
5.2 Legal Framework.....	5-3
5.3 Design Specifications by Roadway Type and Land Use	5-4
5.4 Sidewalk Space.....	5-6
5.4.1 Frontage Zone	5-7
5.4.2 Sidewalk/Pedestrian Zone.....	5-8
5.4.3 Furnishing Zone	5-9
5.5 Landscaping in Parkways.....	5-10
5.5.1 Street Trees and Plantings.....	5-11
5.5.2 Tree Wells.....	5-11
5.5.3 Continuous Planting Strip.....	5-12
5.6 Curb Ramps	5-14
5.7 Utilities	5-16
5.8 Street Furnishings	5-18
5.8.1 Transit Stops.....	5-18
5.8.2 Bike Parking.....	5-18
5.8.3 Seating.....	5-18
5.8.4 Dumpster Location	5-20
5.9 Street Lighting	5-20
CHAPTER 6 - INTERSECTION DESIGN.....	6-3
6.1 Introduction	6-3
6.2 Intersection Type Selection	6-3
6.3 Basic Intersection Forms	6-3
6.4 Intersection Functional Area	6-4
6.5 Design Objectives	6-5
6.6 Design Principles.....	6-5
6.7 Design Guidelines	6-6
6.7.1 Design Vehicles	6-6
6.7.2 Alignment and Profile	6-9
6.7.3 Intersection Sight Distance.....	6-9
6.7.4 Curb Radii.....	6-11
6.7.5 Channelization	6-13
6.7.6 Auxiliary lanes.....	6-14
6.7.7 Curb Extensions (Bulbouts).....	6-17
6.7.8 Controlled Crosswalks.....	6-18
6.7.9 Curb Ramp Placement.....	6-18
6.7.10 Median End Treatment.....	6-18
6.8 Other Intersection Designs	6-19
6.8.1 Roundabouts.....	6-19
6.8.2 Skewed Intersection.....	6-19
6.8.3 Multi-Leg Intersection	6-20
6.9 Intersection Control	6-21
6.9.1 Uncontrolled Intersection.....	6-21
6.9.2 Yield Controlled Intersection.....	6-21
6.9.3 Stop-Controlled Intersection.....	6-22

6.9.4	Signalized Intersection	6-22
CHAPTER 7 - MIDBLOCK CROSSING.....		7-2
7.1	Introduction	7-2
7.2	Applications.....	7-2
7.3	Design Guidelines	7-2
7.3.1	Midblock Crossings Through Medians.....	7-3
7.3.2	Raised Crosswalks.....	7-4
7.4	Types of Midblock Crossing Control	7-6
7.4.1	Non-Actuated Midblock Crossings.....	7-6
7.4.2	Actuated Midblock Crossings	7-6
7.5	Midblock Pedestrian Crossing Toolbox.....	7-9
CHAPTER 8 - ACCESS CONTROL AND OFF-STREET PARKING.....		8-2
8.1	Introduction	8-2
8.2	Access Control	8-2
8.2.1	Highways	8-2
8.2.2	City Streets	8-2
8.3	Access Design.....	8-2
8.3.1	Number of Access Points	8-2
8.3.2	Driveway Design	8-3
8.3.3	Driveway Spacing	8-3
8.4	Parking Lot Design.....	8-6
8.4.1	Design Guidelines.....	8-7
CHAPTER 9 - TRANSIT ACCOMMODATION.....		9-2
9.1	Introduction	9-2
9.2	Designing Streets for Transit	9-2
9.3	Access to Transit.....	9-3
9.4	Transit Facilities	9-4
9.5	Bus Stop Placement.....	9-4
9.6	Transit Shelters	9-4
9.6.1	Overview.....	9-4
9.6.2	Considerations	9-4
9.6.3	Guidance.....	9-4
9.7	Transit Stop Accessibility.....	9-5
9.8	Transit-Specific Streetscape Elements	9-5
9.9	Transit Priority	9-5
9.10	Bicycle Access and Parking.....	9-6
9.10.1	Shared Bicycle/Transit Lanes.....	9-6
9.10.2	Off-Street Separated Bike Lanes at Transit Stops	9-8
9.10.3	Bike Parking in Transit Corridors.....	9-10
9.11	Accommodating Rail, BRT and Paratransit.....	9-10
9.11.1	Commuter Rail	9-10
9.11.2	Bus Rapid Transit (BRT)	9-10
9.11.3	Paratransit.....	9-10
CHAPTER 10 - STREETSCAPE ECOSYSTEM.....		10-2

- 10.1 Introduction 10-2
- 10.2 Stormwater Management 10-2
 - 10.2.1 Planters.....10-2
 - 10.2.2 Swales10-3
 - 10.2.3 Curb Extensions.....10-3
- 10.3 Urban Forestry 10-4
 - 10.3.1 Considerations10-4
 - 10.3.2 Guidance.....10-5
- CHAPTER 11 - PROCEDURAL POLICIES..... 11-2**
- 11.1 Street Closure Policy..... 11-2
 - 11.1.1 Temporary Street Closure for Purposes Other than Construction and/or Maintenance11-2
 - 11.1.2 Temporary Street Closure of Local (Residential) Streets for Construction and/or Maintenance11-2
 - 11.1.3 Local (Residential) Streets to be Closed More Than 10 Calendar Days11-2
 - 11.1.4 Collector and Thoroughfares to be Closed Fewer than 10 Calendar Days 11-3
 - 11.1.5 Collector and Thoroughfares to be Closed More Than 10 Calendar Days .11-3
 - 11.1.6 Supplementary Notification Procedures11-3
 - 11.1.7 Barricading.....11-4
 - 11.1.8 Street Classifications.....11-4
- 11.2 Restricted Parking on Residential Streets..... 11-4
 - 11.2.1 Removal of Parking for Entire Block Face11-4
 - 11.2.2 Removal of Parking for less than Entire Block Face11-4
- 11.3 Temporary Use of Parking Meter Space..... 11-5
 - 11.3.1 Authority.....11-5
 - 11.3.2 Meter Rental/Bagging Requests and Fees11-5
 - 11.3.3 Waiver of Fees11-5
 - 11.3.4 Payment.....11-6
 - 11.3.5 Meter Rental/Bagging Procedure11-6
- CHAPTER 12 - TRAFFIC IMPACT ANALYSIS GUIDELINES..... 12-3**
- 12.1 Introduction 12-3
- 12.2 Responsibility 12-3
- 12.3 Determination of Need..... 12-3
 - 12.3.1 Special Circumstances.....12-4
 - 12.3.2 Study Update12-4
- 12.4 Study Type Requirements 12-4
 - 12.4.1 Methodology Memo Requirements.....12-4
 - 12.4.2 TIA Contents12-7

List of Figures

Figure 2-1. Thoroughfare Land Access vs. Mobility.....	2-3
Figure 2-2. Sample Roadway Cross Sections	2-5
Figure 2-3. Sample Roadway Cross Sections (continued).....	2-6
Figure 3-1. Stopping Sight Distance.....	3-12
Figure 3-2. Horizontal Sight Distance.....	3-13
Figure 3-3. Horizontal Curve Variables.....	3-15
Figure 3-4. Vertical Curve Elements.....	3-16
Figure 3-5. Crest Vertical Curve Types	3-17
Figure 3-6. Sag Vertical Curve Types	3-18
Figure 3-7. Pavement Transition Tapers	3-19
Figure 3-8. Median Types	3-24
Figure 3-9. On Street Parking Types.....	3-27
Figure 3-10. Driveway Angle	3-30
Figure 3-11. Right-Sized Roadway Retrofit Examples.....	3-33
Figure 3-12. Alley Turnouts.....	3-36
Figure 3-13. Driveway Variables	3-37
Figure 3-14. Cul-De-Sac Geometry.....	3-39
Figure 4-1. Facility Selection for Interested but Concerned	4-6
Figure 4-2. Facility Selection for Highly Confident Bicyclists.....	4-6
Figure 4-3. Bicyclist Design User Profiles.....	4-11
Figure 4-4. Typical Section Selection Process (MTP).....	4-12
Figure 4-5. Example Driveway Crossing Solution for a Shared-Use Path.....	4-13
Figure 4-6. Example of a Cross Section with a Separated Bike Lane	4-14
Figure 4-7. Vertical Separation Elements. From Left: Raised Island, Flexible Delineator Post, Rigid Bollards.....	4-17
Figure 4-8. One-Way Separated Bike Lane Widths by Bicyclist Frequency	4-18
Figure 4-9. Two-Way Separated Bike Lane Widths by Bicyclist Frequency	4-19
Figure 4-10. Varying Levels of One-way Separated Bicycle Lane Separation	4-19
Figure 4-11. Varying Levels of Two-Way Separated Bicycle Lane Separation	4-20
Figure 4-12. Buffered Bicycle Lane Width Guidance	4-21
Figure 4-13. Example Cross Section with Contra-flow Bicycle Lanes.....	4-23
Figure 4-14. Different Bicycle Lane Locations. From Left: Bike Lane Adjacent to Parking, Bike Lane Adjacent to a Curb, Bike Lane with Door Zone Marking	4-24
Figure 4-15. Advisory Bicycle Lane Design Guidance	4-28
Figure 4-16. Design Guidance for Shared Lane Markings.....	4-30
Figure 4-17. Preferred Design of a Separated Bike Lane Transition to a Shared Bike Lane..	4-31
Figure 4-18. Preferred Design of a Separated Bicycle Lane Transition to a Conventional Bicycle Lane.....	4-33
Figure 4-19. Preferred Design of a Two-Way Separated Bicycle Lane Transition to a One-Way Separated Bicycle Lane on a Cross Street.....	4-35
Figure 4-20. Preferred Design of a One-Way Separated Bicycle Lane Transition to a One-Way Separated Bicycle Lane on a Cross Street.....	4-37
Figure 4-21. Bicycle Box with Lead-In Bicycle Lane, HAWK Beacon.....	4-41
Figure 4-22. Example Bicycle Signals	4-42
Figure 4-23. Example Bicycle Box.....	4-43

Figure 4-24. Two-Stage Turn Queue Box Design with Consideration of Truck Turning Movements 4-45

Figure 4-25. Preferred Mixing Zone Design..... 4-47

Figure 4-26. Preferred Design of a Through Bicycle Lane Approach..... 4-49

Figure 4-27. Dotted Line Extensions, Bicycle Lane Markings, Colored Conflict Area, Colored Dash, Elephant’s Feet 4-50

Figure 4-28. A Shared-Use Path Realignment to Achieve a 90-Degree Crossing 4-52

Figure 4-29. Preferred Protection Intersection Designs 4-53

Figure 4-30. Example Design of a Separated Bicycle Lane at a Roundabout..... 4-55

Figure 4-31. Example Design of a Separated Bicycle Lane at a Driveway 4-56

Figure 4-32. Bridges Accommodating Pedestrians and Bicyclists 4-57

Figure 4-33. Installation of a Separated Bicycle Facility 4-59

Figure 4-34. A Separated Bicycle Lane with Leaf Debris..... 4-60

Figure 4-35. Example Designs of On-Street Bicycle Parking..... 4-64

Figure 5-1. Sidewalk Space 5-7

Figure 5-2. Café Seating in the Frontage Zone 5-8

Figure 5-3. Benches, Street Lighting, and Trash Cans in the Furnishing Zone 5-10

Figure 5-4. Tree Wells in the Furnishing Zone..... 5-12

Figure 5-5. Continuous Planting Strips in the Furnishing Zone, Mid-Way, and Frontage Zone Positions 5-13

Figure 5-6. Example Intersection with Curb Ramps at All Approaches 5-15

Figure 5-7. Flared Curb Ramp (left) and Non-Flared Curb Ramp (right)..... 5-16

Figure 6-1. Common Intersection Types 6-4

Figure 6-2. Intersection Physical Area..... 6-4

Figure 6-3. Intersection Functional Area..... 6-5

Figure 6-4. Typical Design Vehicle Dimensions 6-8

Figure 6-5. Intersection Sight Triangles..... 6-11

Figure 6-6. Curb Radius Design Types 6-12

Figure 6-7. Types of Islands..... 6-14

Figure 6-8. Auxiliary Turn Lane Components 6-15

Figure 6-9. Left-Turn Lane Offsets 6-16

Figure 6-10. Curb Extension Applications 6-18

Figure 6-11. Intersection Realignment Options (AASHTO Green Book (2018))..... 6-20

Figure 6-12. Realigning Multi-Leg Intersections (AASHTO Green Book (2018))..... 6-21

Figure 7-1. Midblock Crossing Example 7-4

Figure 7-2. Raised Crosswalk 7-5

Figure 7-3. Pedestrian HAWK Signal 7-8

Figure 7-4. Pedestrian RRFB 7-9

Figure 8-1. Minimum Street and Access Connection Spacing ([Access Management Policy](#)) .. 8-4

Figure 8-2. Minimum Street and Access Connection Spacing with Roundabouts ([Access Management Policy](#)) 8-5

Figure 8-3. Parking Variables..... 8-6

Figure 8-4. Parking Lot Layout Dimensions..... 8-8

Figure 9-1. Overview of Shared Bicycle/Transit Lanes 9-7

Figure 9-2. Example Separated Bike Lane at Transit Stop 9-9

Figure 12-1. Trip Distribution Example Exhibit..... 12-6

Figure 12-2. Existing Lane Assignment and Traffic Control Example Exhibit..... 12-8



Figure 12-3. Existing Traffic Volumes Example Exhibit 12-9

List of Tables

Table 2-1. Typical Minimum Continuous Segment Length.....	2-7
Table 3-1. System Link Roadway Design Criteria (SYS)	3-5
Table 3-2. Commercial Connector Roadway Design Criteria (CCO)	3-6
Table 3-3. Neighborhood Connector Roadway Design Criteria (NCO)	3-7
Table 3-4. Commerce/Mixed-Use Roadway Design Criteria (CMU)	3-8
Table 3-5. Activity Street Roadway Design Criteria (ACT).....	3-9
Table 3-6. Street Type Target Speeds (mph)	3-10
Table 3-7. Street Type Treatments based on Average Daily Traffic (vpd)	3-11
Table 3-8. Minimum Radii for Low-Speed Urban Streets.....	3-14
Table 3-9. Design Controls for Crest Vertical Curves Based on Stopping Sight Distance.....	3-17
Table 3-10. Design Controls for Sag Vertical Curves	3-18
Table 3-11. Pavement Transition Length.....	3-20
Table 3-12. Minimum Offset for Driveways on Opposite Sides of a Roadway	3-29
Table 3-13. Implementation of Right-Sized Roadways	3-34
Table 3-14. Alley and Alleyway Turnout Design Criteria	3-35
Table 3-15. Cul-De-Sac/Dead-End Geometric Design Standards	3-40
Table 4-1. Bicycle Facility Selection Criteria by Roadway Type	4-7
Table 4-2. Intersection Control Treatments for Bicycle Facilities by Roadway Type	4-9
Table 4-3. Bicycle Lane Object Setbacks	4-16
Table 4-4. Traffic Volume Thresholds for Bicycle Boulevard Treatments.....	4-39
Table 4-5. Shifting Taper Equation.....	4-47
Table 5-1. Land Uses Along Roadways	5-5
Table 5-2. Minimum Pedestrian Zone Widths by Roadway Type	5-6
Table 6-1. Recommended Design Vehicle Based on Street Type	6-7
Table 6-2. Intersection Sight Distance.....	6-11
Table 6-3. Minimum Curb Radii.....	6-13
Table 7-1. Pedestrian Crossing Toolbox for Midblock Crossings.....	7-10
Table 7-2. Recommended Pedestrian Applications at Uncontrolled Crossing Locations	7-11
Table 8-1. Parking Space Sizes	8-7
Table 12-1. Study Type and Submittal Requirements	12-3
Table 12-2. Trip Generation Example Table.....	12-5
Table 12-3. Trip Generation Rates/Equation Example Table.....	12-10
Table 12-4. Background Growth Rate Calculation Example Table	12-10
Table 12-5. Intersection Capacity Analysis Example Table	12-11
Table 12-6. Thoroughfare Capacity Analysis Example Table	12-12
Table 12-7. Mitigation Requirements.....	12-13
Table 12-8. Mitigation Example Table	12-13



Contents

CHAPTER 1 - INTRODUCTION AND CONTEXT	1-2
1.1 What is the Transportation Engineering Manual?	1-2
1.2 Purpose of Manual	1-3
1.3 Existing Local and National Best Practices.....	1-3
1.3.1 National Standards and Guidelines that Govern the Design of Streets.....	1-4
1.3.1.1 Street Design.....	1-4
1.3.1.2 Bicycle and Pedestrian Design	1-5
1.3.1.3 Transit Design.....	1-5
1.3.1.4 Complete Streets	1-5
1.3.1.5 Street Stormwater	1-5



List of Figures

N/A

List of Tables

N/A

CHAPTER 1 - INTRODUCTION AND CONTEXT

1.1 WHAT IS THE TRANSPORTATION ENGINEERING MANUAL?

For the City of Fort Worth, the Transportation Engineering Manual defines the design requirements for transportation infrastructure. The design requirements outlined in this manual offer recommendations of standards and criteria for design questions that frequently arise in transportation planning, traffic operations, street design, and site development. The key intention of the manual is to provide consistency of traffic and transportation design practices for existing and future site development in the City. In addition, the Transportation Engineering Manual provides design criteria for street elements required by the City's adopted [Master Thoroughfare Plan \(MTP\)](#) and [Complete Streets Policy](#).

This manual is intended for use as a professional design resource by the City, the professional development community, and any individuals or groups involved in the planning and design of the City's street network. The manual applies to all projects that impact public right-of-way along the City streets, including improvements to existing streets and alleys, construction of new streets, and redevelopments.

This Manual contains 12 chapters to guide the City in its street design.

- Chapter 1. Introduction and Context. This chapter provides the background on the manual and establishes the vision for implementing Complete Streets into the City through local and national design standards.
- Chapter 2. Thoroughfare Framework. This chapter establishes the framework of the streets and thoroughfares throughout the City through the application of an updated roadway network classification, as governed by the MTP.
- Chapter 3. Street Design. This chapter details components and design elements of the travel way and its effects on the full right-of-way.
- Chapter 4. Bicycle Facilities. This chapter encourages design solutions for providing better and safer traveling conditions for bicyclists within the City.
- Chapter 5. Pedestrian Zone. This chapter prescribes methods to make the pedestrian environment more universally accessible.
- Chapter 6. Intersection Design. This chapter outlines the necessary and recommended accommodations behind designing intersections for all roadway users.
- Chapter 7. Midblock Crossing. This chapter presents solutions and criteria to integrate pedestrians and safer pedestrian crossings into the roadway network.
- Chapter 8. Access Control and Off-Street Parking. This chapter describes the guidelines and design criteria behind off-street parking and access control to commercial, multi-family, and industrial properties.
- Chapter 9. Transit Accommodation. This chapter offers criteria and standards to integrate transit into the roadway network, prioritizing it wherever possible.
- Chapter 10. Streetscape Ecosystem. This chapter will be published at a future date.

- Chapter 11. Procedural Policies. This chapter outlines procedural policies for multiple activities which are the responsibility of the Traffic Engineering Section.
- Chapter 12. Traffic Impact Analysis Guidelines. This chapter provides the guidelines and requirements that govern the development of a traffic impact analysis.

1.2 PURPOSE OF MANUAL

The preceding edition of the City of Fort Worth Transportation Criteria Manual was published in July 1987. The purpose of this publication is to provide updates to the design standards based on changes in infrastructure and site development requirements. In addition, this manual will incorporate changes based on national best practices and recent City planning efforts, including the [Master Thoroughfare Plane \(MTP\)](#), [Complete Streets Policy](#), [Access Management Policy](#), and [Active Transportation Plan \(ATP\)](#).

Updated design requirements in this manual are intended to shift the street network into a more sustainable system that promotes a healthy community, in keeping with the goals of the [MTP](#), [Complete Streets Policy](#) and [ATP](#).

1.3 EXISTING LOCAL AND NATIONAL BEST PRACTICES

The City of Fort Worth practices a design and planning approach which recognizes the quality of existing plans and strategies already in place for bicycles, pedestrian, and transit and the importance of incorporating them into the design process.

These plans remain freestanding strategies and are periodically updated to reflect changing circumstances and emerging trends and best practices. Fort Worth will benefit from these incremental enhancements over time by allowing them to inform the decision-making process of street design.

The following locally adopted documents represent the latest standards guidelines and policies that govern the design in Fort Worth:

- [Active Transportation Plan](#) – The Active Transportation Plan (ATP) is the update to the City’s Bike and Walk Fort Worth Plans and also serves as the City’s first trails master plan. This plan also focuses heavily on first-mile and last-mile connections to transit.
- [The Transit Master Plan](#) – The Transit Master Plan is a 20-year plan governed by Trinity Metro designed to improve and expand transit services and policies for the Fort Worth/Tarrant County region.
- [Complete Street Policy](#) – The goal of Fort Worth’s Complete Streets Policy is to ensure that streets are designed, operated, and maintained to enable safe and comfortable access for all users, regardless of age, ability, or mode of transportation.
- [Master Thoroughfare Plan](#) – The Master Thoroughfare Plan (MTP) establishes the right-of-way, alignment, and cross-section for the City’s thoroughfare network to facilitate orderly and sustainable growth.

- [Subdivision Ordinance](#) – The Subdivision Ordinance guides the land development process and protects the public from inferior and undesirable development practices. The Ordinance governs streets, alleys, driveways, easements, drainage facilities, street lighting, lots and blocks, and park dedication.
- [Zoning Ordinance](#) – The Zoning Ordinance defines how property in the city can be used.
- [Access Management Policy](#) – This policy provides for and manages access to land development, while preserving the regional flow of traffic in terms of safety, capacity and speed.
- [Stormwater Criteria Manual](#) – This manual provides design criteria and a framework for incorporating effective and environmentally sustainable stormwater management into the site development and construction processes.

The following state adopted documents represent the latest standards guidelines and policies that govern design in Texas:

- [TxDOT Access Management Manual](#)
- [Texas Manual on Uniform Traffic Control Devices \(TMUTCD\)](#)
- [Texas Accessibility Standards \(TAS\)](#)

1.3.1 National Standards and Guidelines that Govern the Design of Streets

1.3.1.1 Street Design

- [AASHTO A Policy on Geometric Design of Highways and Streets \(the Green Book\)](#)
- [Highway Capacity Manual](#)
- [Manual on Uniform Traffic Control Devices \(MUTCD\)](#)
- [FHWA NCHRP Report 672 – Roundabouts: An Informational Guide](#)
- [FHWA Flexibility in Highway Design](#)
- [NACTO Urban Street Design Guide](#)
- [FHWA Road Diet Informational Guide](#)
- [FHWA Traffic Calming ePrimer](#)
- [FHWA Guide for Improving Pedestrian Safety at Uncontrolled Crossing Locations](#)
- [ITE Trip Generation Manual](#)

1.3.1.2 *Bicycle and Pedestrian Design*

- [NACTO Urban Bikeway Design Guide](#)
- [FHWA Separated Bike Lane Planning and Design Guide](#)
- [FHWA Bicycle and Pedestrian Facility Design Flexibility](#)
- [AASHTO Guide for the Development of Bicycle Facilities](#)
- [CNU/ITE Manual for Designing Walkable Urban Thoroughfares a Context Sensitive Approach](#)
- [Public Right-of-Way Accessibility Guidelines \(PROWAG\)](#)
- [FHWA NCHRP Report 672 – Roundabouts: An Informational Guide](#)
- [NACTO Urban Street Design Guide](#)
- [APBP Bicycle Parking Guidelines](#)
- [APBP Essentials of Bicycle Parking: Selecting and Installing Bicycle Parking that Works](#)
- [FHWA Shared Use Path Level of Service Calculator](#)
- [Fundamentals of Bicycle Boulevard Planning & Design](#)

1.3.1.3 *Transit Design*

- [NACTO Transit Street Design Guide](#)

1.3.1.4 *Complete Streets*

- [ITE Context Sensitive Solutions](#)
- [CNU/ITE Implementing Context-Sensitive Design on Multimodal Corridors: A Practitioner's Handbook](#)
- [APA Complete Streets: Best Policies and Implementation Practices](#)
- [NACTO Urban Street Design Guide](#)

1.3.1.5 *Street Stormwater*

- [NACTO Urban Street Stormwater Guide](#)

Contents

CHAPTER 2 - THOROUGHFARE FRAMEWORK.....	2-2
2.1 Street Typology	2-2
2.1.1 Street Type	2-2
2.1.1.1 Non-Thoroughfare	2-3
2.1.1.2 Thoroughfare/Non-Thoroughfare	2-4
2.2 Cross Sections	2-4
2.2.1 Overview	2-4
2.3 Street Pattern and Connectivity	2-7
2.3.1 Street and Block Arrangements.....	2-7
2.3.2 Street Length	2-7
2.3.2.1 Design Criteria	2-7

List of Figures

Figure 2-1. Thoroughfare Land Access vs. Mobility.....	2-3
Figure 2-2. Sample Roadway Cross Sections	2-5
Figure 2-3. Sample Roadway Cross Sections (continued)	2-6

List of Tables

Table 2-1. Typical Minimum Continuous Segment Length	2-7
--	-----

CHAPTER 2 - THOROUGHFARE FRAMEWORK

2.1 STREET TYPOLOGY

The City's [MTP](#) defines specific requirements for thoroughfares within the City, including right-of-way width, alignment, and cross-section. The [MTP](#) defines thoroughfares as “facilities that serve moderate-length to long trips and moderate to high traffic volumes, and typically interconnect with and augment the interstate and state highway systems.” The attributes of the thoroughfare classifications are described below for the ease of the reader, as they are referenced within this document. However, detailed information about [MTP](#) requirements, goals, and administration can be found in the [MTP](#) itself.

2.1.1 Street Type

The [MTP](#) categorizes all thoroughfares into one of five Street Types based on surrounding land use, segment characteristics, and network function, as follows:

- **Activity Streets.** Activity Streets are “destination streets.” They are typically retail-oriented, automobile speeds are slow, parking is typically on-street, sidewalks are wide to support sidewalk cafes and other amenities, and building facades front the street.
- **Commerce/Mixed-Use Streets.** Commerce/Mixed Use Streets are often found downtown among office/commercial-oriented land uses. On-street and structured parking are both common, automobile speeds are fairly slow, and sidewalks are wide and busy.
- **Neighborhood Connectors.** Neighborhood Connectors provide access from neighborhoods to services, typically running along the boundaries of residential areas, with moderate speeds and buildings set back from the street.
- **Commercial Connectors.** Commercial Connectors serve retail portions of the City, and often have some driveway connections, medians, and center turn lanes. Automobile speeds are moderate to high, and the outside lane is slightly wider to accommodate design vehicles and a high volume of turning movements.
- **System Links.** System Links serve longer-distance travel and often provide connections from the local network to freeways; automobile speeds are moderate to high, and raised medians are required to separate traffic and facilitate left turns.

Figure 2-1 shows land access and mobility change with each Street Type.

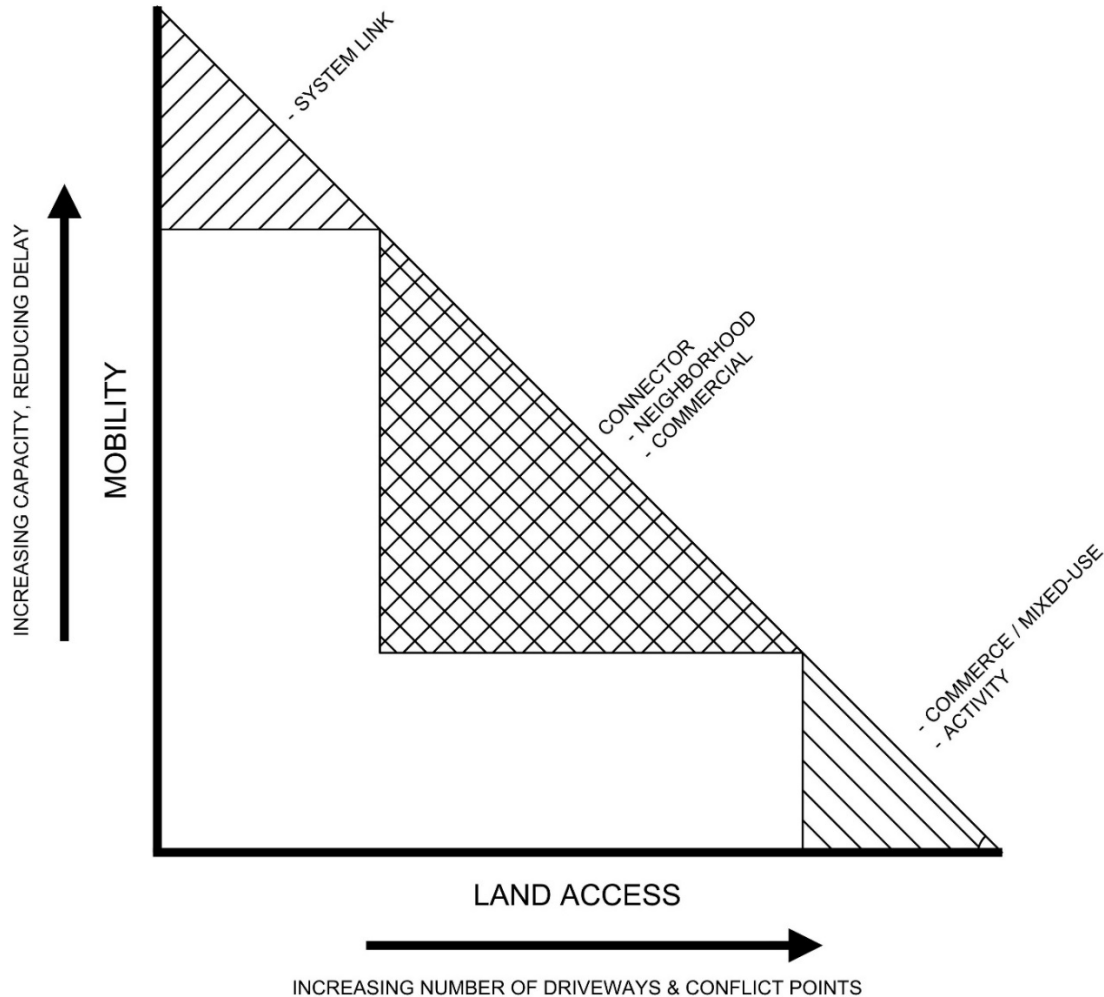

Figure 2-1. Thoroughfare Land Access vs. Mobility

2.1.1.1 Non-Thoroughfare

The street network also includes streets that are not classified as thoroughfares, as follows:

- **Collectors.** Collectors provide critical supporting connections to the overall transportation network and can reduce traffic pressure by allowing for shorter trips to be made off the thoroughfare network. While the [MTP](#) does not map collectors, it does provide requirements on typical cross-sections. The [Subdivision Ordinance](#) contains criteria on when collectors are required.
- **Urban Local Streets.** Urban local streets are residential facilities that carry traffic to and from collectors and other residential streets. They usually serve low-density areas in conjunction with collectors. While the [MTP](#) does not map local streets, it does provide requirements on typical cross-sections.
- **Limited Local Streets.** Limited local streets serve clusters or zero-lot-line housing. While the [MTP](#) does not map local streets, it does provide requirements on typical cross-sections.

2.1.1.2 *Thoroughfare/Non-Thoroughfare*

The street network includes streets that can be classified as either a thoroughfare or not a thoroughfare, as follows:

- **Special Districts.** There are two districts within the City that have pre-established street designations and design standards. These design standards supersede those established by the [MTP](#). These districts include:
 - Trinity Lakes (I-820/Trinity Boulevard)
 - Panther Island (immediately north of Downtown)
- **Park-Adjacent Streets.** When a thoroughfare is adjacent to a park, the frontage zone should be eliminated, and the extra width should be shifted to the clearance and furnishing zones. This will allow the pedestrian zone, sidewalk, or sidepath to abut the right-of-way line.
- **Industrial Streets.** Industrial streets are established for industrial areas to allow for different types of vehicles (i.e., larger turning radii, heavier industrial type traffic, wheel loads). These roads are minor thoroughfares that serve industrial traffic traveling between a thoroughfare system and industrial districts.

2.2 CROSS SECTIONS

2.2.1 Overview

Cross sections in the [MTP](#) illustrate the required widths of lanes and other elements on a roadway. These elements can include features such as medians, sidewalks, and shared-use paths. Each segment of the thoroughfare network is assigned a specific cross section in the [MTP](#) with elements suited to the traffic characteristics and surrounding land use.

The [MTP](#) specifies a particular cross-section for each segment of the thoroughfare network, based on six variables listed below:

- **Street Type.** Under which of the 5 Street Types can this facility be classified?
- **Lanes.** How many lanes per direction?
- **Transit.** What type of special transit facility, if any?
- **Median.** What type of median, if any?
- **Parking.** What type of parking, if any?
- **Bikes.** What type of bike facility?

Each selection process will result in a code and implied right-of-way that defines the cross section. The first of these inputs, Street Type, was defined in Street Typology, Section 2.1 of this chapter.

A typical cross section for the various street types are shown in **Figure 2-2**. The cross sections are for illustrative purposes to illustrate the difference between the street types. The flex space may be used for an additional buffer, pedestrian zone or side path depending on context. The maximum grades are based on level terrain. Refer to the [MTP](#) for dimensions.

SYSTEM LINK: SYS-L2-T0-NTMS-PO-BOP

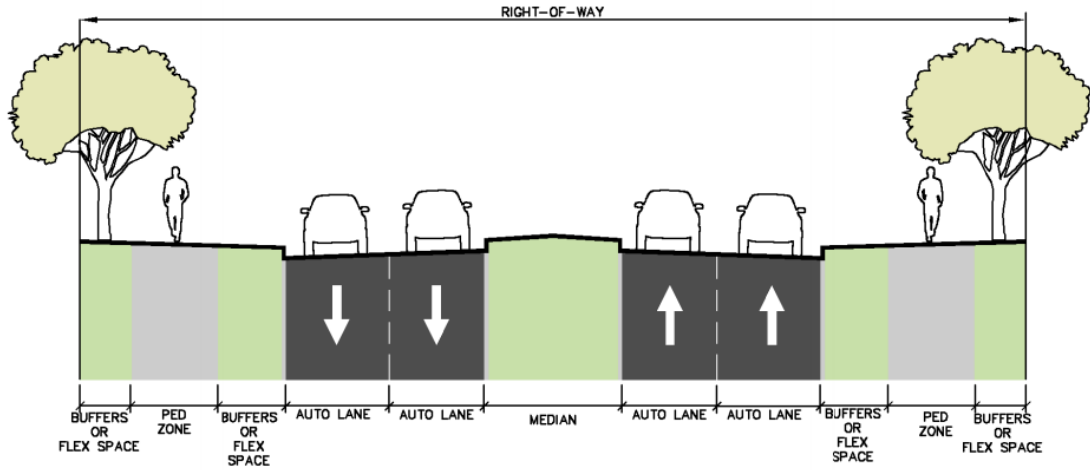

COMMERCIAL CONNECTOR: CCO-L1-TD-NTMS-PO-BLC

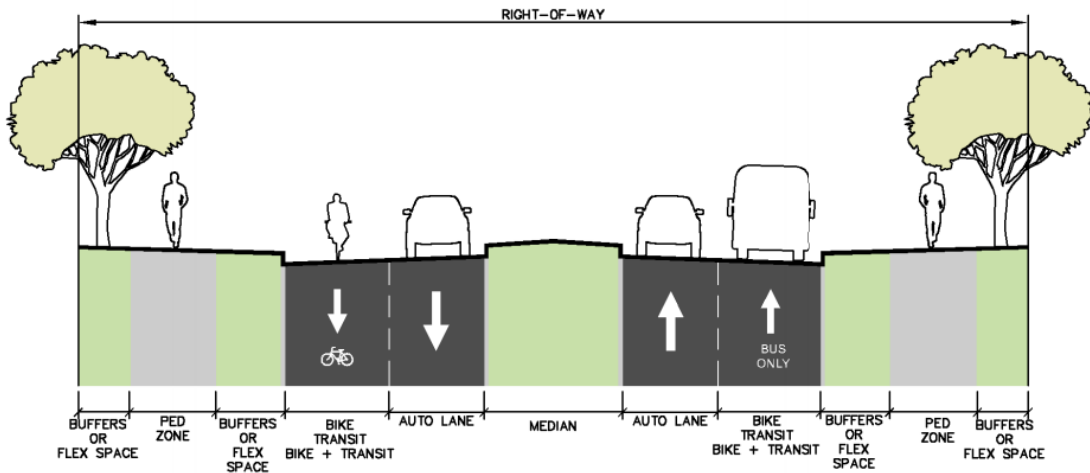
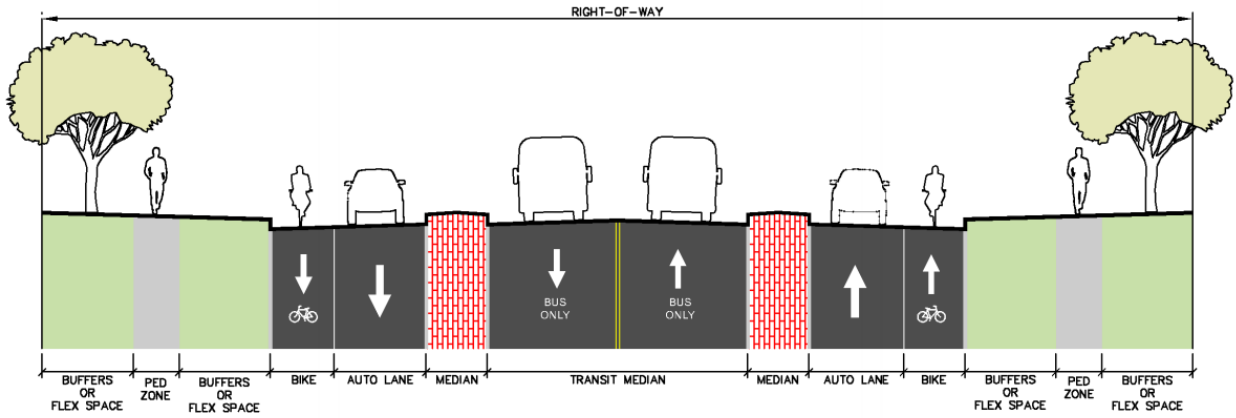
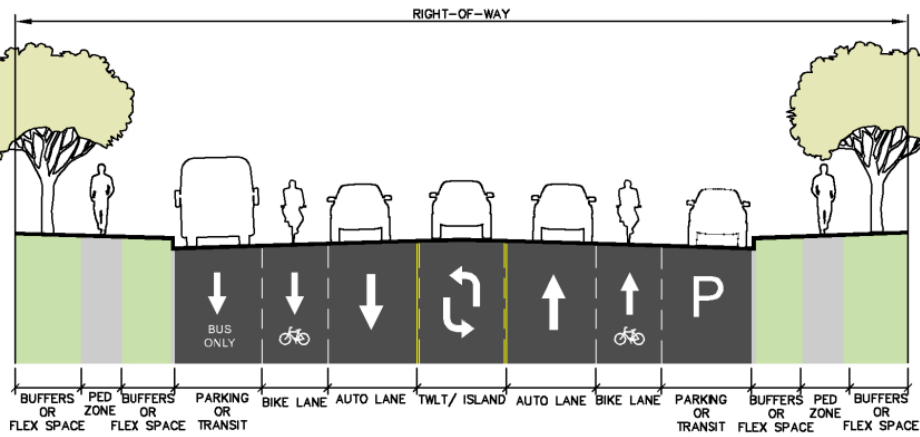

Figure 2-2. Sample Roadway Cross Sections

NEIGHBORHOOD CONNECTOR: NCO-L1-TM-NTMT-P0-BLC



COMMERCE/ MIXED-USE STREET: CMU-L1-TP-TWLT-PP-BLB



ACTIVITY STREET: ACT-L1-TD-NTMN-PP-BLC

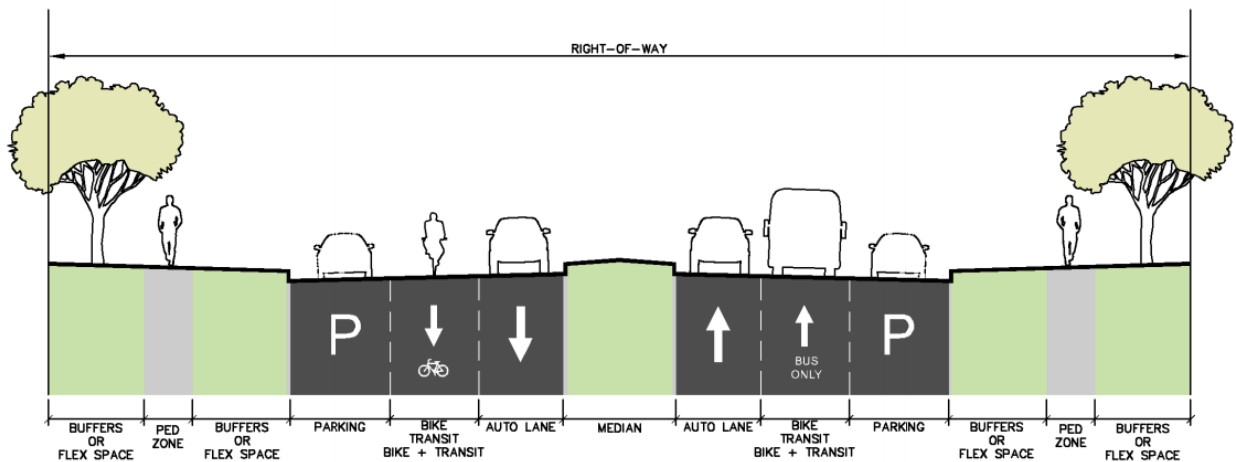

Figure 2-3. Sample Roadway Cross Sections (continued)

2.3 STREET PATTERN AND CONNECTIVITY

Street pattern and connectivity refer to the arrangement, character, extent, and location of streets within the City. An effective street pattern design will allow for more direct connections between roadways, and this stronger connectivity grants travelers the option to take shorter and more efficient routes. Design parameters shall be governed by the [Subdivision Ordinance](#) and the [MTP](#), while considering the existing environment, drainage, topography, and public safety and convenience.

The elements of street pattern and connectivity consist of the following roadway features: street and block arrangements and street length.

2.3.1 Street and Block Arrangements

Connectivity is maximized when streets and blocks are arranged in an efficient way. Refer to the [Subdivision Ordinance](#) for guidance on internal and external roadway network connectivity.

2.3.2 Street Length

The length of a roadway segment can vary depending on its specific Street Type classification, which, in turn, is based on the segment’s traffic patterns and land-use contexts.

2.3.2.1 Design Criteria

Table 2-1 summarizes the minimum desired lengths for continuous segments of different Street Types.

Table 2-1. Typical Minimum Continuous Segment Length

Street Type	Length
Activity Street	Single Block
Commerce/Mixed-Use Street	Single Block
Neighborhood Connector	½ mile
Commercial Connector	½ mile
System Link	2 miles
Limited Local Streets	*

* = Limited local streets cannot exceed 800 feet in length

Contents

CHAPTER 3 - STREET DESIGN	3-4
3.1 Introduction	3-4
3.2 Design Controls.....	3-10
3.2.1 Design Speed/Target Speed	3-10
3.2.1.1 Design Criteria	3-10
3.2.2 Design Volume.....	3-10
3.2.2.1 Design Criteria	3-11
3.2.3 Stopping Sight Distance	3-12
3.2.3.1 Design Criteria	3-12
3.2.4 Horizontal Sight Distance	3-12
3.2.4.1 Design Criteria	3-12
3.3 Design Elements	3-14
3.3.1 Horizontal Alignment.....	3-14
3.3.1.1 Design Criteria	3-14
3.3.2 Vertical Alignment	3-15
3.3.2.1 Grades.....	3-15
3.3.2.2 Vertical Curves	3-15
3.3.3 Pavement Cross and Side Slopes.....	3-19
3.3.3.1 Pavement Cross Slopes	3-19
3.3.3.2 Side Slopes	3-19
3.3.4 Pavement Transition	3-19
3.3.4.1 Design Criteria	3-20
3.3.4.2 Guidance	3-20
3.3.5 Signage and Pavement Markings.....	3-20
3.3.5.1 Street Name Sign Installation Policy	3-20
3.4 Other Elements	3-21
3.4.1 Roadway Drainage.....	3-21
3.4.2 Public Right-of-Way Visibility Requirements.....	3-21
3.4.3 Street Lighting.....	3-21
3.4.3.1 General.....	3-21
3.4.3.2 Policy and Procedures	3-21
3.4.3.3 Engineering	3-22
3.4.3.4 Construction	3-23
3.4.3.5 Financial Responsibility	3-23
3.4.3.6 Ownership and Maintenance	3-23
3.4.3.7 Special Districts	3-23
3.4.4 Medians	3-24
3.4.4.1 Types.....	3-24
3.4.4.2 Design Criteria	3-25
3.4.5 On-Street Parking	3-26
3.4.5.1 Types of On-Street Parking.....	3-26
3.4.5.2 Design Criteria	3-28
3.4.5.3 Guidance	3-28

- 3.4.6 Access Management.....3-29
 - 3.4.6.1 Driveway Spacing 3-29
 - 3.4.6.2 Lining Up Driveways across Roadways 3-29
 - 3.4.6.3 Angle of Intersection to the TxDOT Roadway 3-29
 - 3.4.6.4 Driveways and Accommodation of Pedestrians 3-30
 - 3.4.6.5 Driveways and Accommodation of Bicycles 3-31
 - 3.4.6.6 Vehicle Stacking at Gates 3-31
- 3.4.7 Complete Street Components3-32
- 3.4.8 Right-Sized Roadways3-32
 - 3.4.8.1 Design Criteria 3-34
 - 3.4.8.2 Guidance 3-34
- 3.4.9 Established Thoroughfares3-34
- 3.4.10 Air Rights3-35
- 3.5 Design Criteria for other Road Classifications 3-35
 - 3.5.1 Alleys and Alleyway Turnouts.....3-35
 - 3.5.1.1 Design Criteria 3-35
 - 3.5.2 Driveways3-36
 - 3.5.2.1 Classifications..... 3-37
 - 3.5.2.2 Location and Spacing 3-37
 - 3.5.2.3 Design Criteria 3-38
 - 3.5.2.4 Review/Exceptions Process..... 3-38
 - 3.5.2.5 Restrictive Provisions..... 3-38
 - 3.5.3 Dead-End Streets and Culs-De-Sac.....3-38
 - 3.5.3.1 Design Criteria 3-39

List of Figures

- Figure 3-1. Stopping Sight Distance..... 3-12
- Figure 3-2. Horizontal Sight Distance..... 3-13
- Figure 3-3. Horizontal Curve Variables 3-15
- Figure 3-4. Vertical Curve Elements..... 3-16
- Figure 3-5. Crest Vertical Curve Types 3-17
- Figure 3-6. Sag Vertical Curve Types 3-18
- Figure 3-7. Pavement Transition Tapers 3-19
- Figure 3-8. Median Types 3-24
- Figure 3-9. On Street Parking Types..... 3-27
- Figure 3-10. Driveway Angle 3-30
- Figure 3-11. Right-Sized Roadway Retrofit Examples..... 3-33
- Figure 3-12. Alley Turnouts 3-36
- Figure 3-13. Driveway Variables 3-37
- Figure 3-14. Cul-De-Sac Geometry..... 3-39

List of Tables

Table 3-1. System Link Roadway Design Criteria (SYS)	3-5
Table 3-2. Commercial Connector Roadway Design Criteria (CCO)	3-6
Table 3-3. Neighborhood Connector Roadway Design Criteria (NCO)	3-7
Table 3-4. Commerce/Mixed-Use Roadway Design Criteria (CMU)	3-8
Table 3-5. Activity Street Roadway Design Criteria (ACT).....	3-9
Table 3-6. Street Type Target Speeds (mph)	3-10
Table 3-7. Street Type Treatments based on Average Daily Traffic (vpd)	3-11
Table 3-8. Minimum Radii for Low-Speed Urban Streets.....	3-14
Table 3-9. Design Controls for Crest Vertical Curves Based on Stopping Sight Distance.....	3-17
Table 3-10. Design Controls for Sag Vertical Curves	3-18
Table 3-11. Pavement Transition Length.....	3-20
Table 3-12. Minimum Offset for Driveways on Opposite Sides of a Roadway	3-29
Table 3-13. Implementation of Right-Sized Roadways	3-34
Table 3-14. Alley and Alleyway Turnout Design Criteria.....	3-35
Table 3-15. Cul-De-Sac/Dead-End Geometric Design Standards	3-40

CHAPTER 3 - STREET DESIGN

3.1 INTRODUCTION

Street design involves the design of the travel way and parkway elements, including sidewalks. Design of the travel way generally dictates the parkway design as sidewalks are primarily designed along the alignment of the travel way.

The travel way is defined as the street area between the two faces of curbs or between two edges of pavement for the streets without curbs. This area generally includes travel lanes and shoulders, but can also include parking lanes, bicycle lanes, transit lanes, medians, and landscaping. The parkway is defined as the area between the outside curb and right-of-way most often occupied by pedestrian facilities, landscaping, and utilities.

This chapter provides the major design elements of the travel way and parkway, including desired dimensions and relevant design criteria for various street functional classes. The various street design criteria are outlined in the following three (3) categories:

- **Design Controls.** These sections cover the major factors that control the design of the various roadway facilities. These are the factors that street or travel way design is based on while determining its geometry.
- **Design Elements.** These sections cover the design of street geometry including horizontal and vertical elements.
- **Other Elements.** These sections include other design elements to take into consideration after the structure and composition of the street has been decided. Implementing measures like traffic calming and placing transition markings on the roadway can promote a safer and more efficient environment for all street users.

Depending on the type of street, different components may be prioritized over others. All design elements should conform to the City's [MTP](#). A summary of design criteria for various street types as defined in **Chapter 2** is shown in **Tables 3-1 to 3-5**. The naming convention for each cross section within each street type can be referenced from the City's [MTP](#).

Table 3-1. System Link Roadway Design Criteria (SYS)

	SYS-L2-T0-NTMS-P0-BLS	SYS-L2-T0-NTMS-P0-BOP	SYS-L2-TD-NTMS-P0-BLS	SYS-L3-T0-NTMS-P0-BLS	SYS-L2-TD-NTMS-P0-BOP	SYS-L3-T0-NTMS-P0-BOP	SYS-L2-TM-NTMT-P0-BOP	SYS-L2-TD-NTMW-P0-BOP	SYS-L3-T0-NTMW-P0-BLS	SYS-L3-T0-NTMW-P0-BOP
ROW (ft)	110	110	130	130	130	130	130	130	130	130
Lane Width (ft)	11	11	11	11	11	11	11	11	11	11
Outside Lane Width (ft)	12	12	NA	12	NA	12	12	NA	12	12
Median Type	Standard	Standard	Standard	Standard	Standard	Standard	Transit	Wide	Wide	Wide
Median Width (ft)	16	16	16	16	16	16	54	28	28	28
Shared Lane Type	NA	NA	Bike + Transit	NA	Bike + Transit	NA	NA	Bike + Transit	NA	NA
Shared Lane Width (ft)	NA	NA	12	NA	12	NA	NA	12	NA	NA
Parking Type	NA	NA	NA	NA	NA	NA	NA	NA	NA	NA
Parking Width (ft)	NA	NA	NA	NA	NA	NA	NA	NA	NA	NA
Sidepath (ft)	NA	10	NA	NA	10	10	NA	10	NA	10
Bike Lane (ft)	6	NA	6	6	NA	NA	NA	NA	6	NA
Ped Zone (ft)	5	NA	5	5	NA	NA	6	NA	5	NA
Buffer (ft)	4.5	4.5	4.5	4.5	4.5	4.5	4.5	6.5	4.5	6.5
Default Target Speed (mph)	40									
Minimum Centerline Radius (ft)*	762									
Maximum Grade (%)	5									
Minimum Grade (%)	0.5									
Minimum Vertical Crest Curve (K)	44									
Minimum Vertical Sag Curve (K)	64									
Design Vehicle	WB-67									

*The minimum centerline radius is based on a 2% normal crown.

This table reflects minimum design criteria. Refer to subsequent sections in this chapter for additional guidance.

Table 3-2. Commercial Connector Roadway Design Criteria (CCO)

	CCO-L1-T0-TWLT-P0-BOP	CCO-L1-T0-TWLT-P0-BLC	CCO-L1-TD-TWLT-P0-BOP	CCO-L2-T0-TWLT-P0-BOP	CCO-L2-T0-TWLT-P0-BLC	CCO-L1-TD-NTMS-P0-BLC	CCO-L2-T0-NTMS-P0-BOP	CCO-L2-T0-NTMS-P0-BLC	CCO-L2-TD-NTMS-P0-BOP	CCO-L3-T0-NTMS-P0-BOP	CCO-L3-T0-NTMS-P0-BLB
ROW (ft)	80	80	110	110	110	110	110	110	130	130	130
Lane Width (ft)	12	11	11	11	11	11	11	11	11	11	11
Outside Lane Width (ft)	12	NA	NA	12	NA	NA	12	NA	NA	12	NA
Median Type	TWLT/Island	TWLT/Island	TWLT/Island	TWLT/Island	TWLT/Island	Standard	Standard	Standard	Standard	Standard	Standard
Median Width (ft)	11	11	11	11	11	16	16	16	16	16	16
Shared Lane Type	NA	NA	Bike + Transit	NA	NA	Bike + Transit	NA	NA	Bike + Transit	NA	NA
Shared Lane Width (ft)	NA	NA	12	NA	NA	12	NA	NA	12	NA	NA
Parking Type	NA	NA	NA	NA	NA	NA	NA	NA	NA	NA	NA
Parking Width (ft)	NA	NA	NA	NA	NA	NA	NA	NA	NA	NA	NA
Sidepath (ft)	10	NA	10	10	NA	10	10	NA	10	10	NA
Bike Lane (ft)	NA	6	NA	NA	6	NA	NA	6	NA	NA	8
Ped Zone (ft)	NA	6	NA	NA	6	NA	NA	6	NA	NA	6
Buffer (ft)	4.5	4.5	4.5	4.5	4.5	4.5	4.5	4.5	4.5	4.5	4.5
Default Target Speed (mph)	35										
Minimum Centerline Radius (ft)*	510										
Maximum Grade (%)	5										
Minimum Grade (%)	0.5										
Minimum Vertical Crest Curve (K)	29										
Minimum Vertical Sag Curve (K)	49										
Design Vehicle	WB-62										

*The minimum centerline radius is based on a 2% normal crown.

This table reflects minimum design criteria. Refer to subsequent sections in this chapter for additional guidance.

Table 3-3. Neighborhood Connector Roadway Design Criteria (NCO)

	NCO-L1-T0-NTMS-P0-BOP	NCO-L1-T0-NTMN-P0-BLC	NCO-L1-T0-TWLT-P0-BOP	NCO-L1-T0-TWLT-P0-BLC	NCO-L1-TD-TWLT-BOP	NCO-L2-T0-TWLT-P0-BOP	NCO-L2-T0-TWLT-P0-BLS	NCO-L1-TD-NTMS-P0-BOP	NCO-L2-T0-NTMS-P0-BOP	NCO-L2-T0-NTMS-P0-BLS	NCO-L3-T0-NTMS-P0-BOP	NCO-L3-T0-NTMS-P0-BLS	NCO-L1-TM-NTMT-P0-BOP	NCO-L1-TM-NTMT-P0-BLC	NCO-L2-TM-NTMT-P0-BSU
ROW (ft)	80	80	80	80	110	110	110	110	110	110	130	130	130	130	130
Lane Width (ft)	16	11	11	11	11	11	11	11	11	11	11	11	16	11	11
Outside Lane Width (ft)	16	NA	11	NA	NA	11	11	NA	11	11	11	11	16	NA	11
Median Type	Narrow	Narrow	TWLT/ Island	TWLT/ Island	TWLT/ Island	TWLT/ Island	TWLT/ Island	Standard	Standard	Standard	Standard	Standard	Transit	Transit	Transit
Median Width (ft)	6	6	11	11	11	11	11	16	16	16	16	16	54	54	54
Shared Lane Type	NA	NA	NA	NA	Bike + Transit	NA	NA	Bike + Transit	NA	NA	NA	NA	NA	NA	NA
Shared Lane Width (ft)	NA	NA	NA	NA	11	NA	NA	11	NA	NA	NA	NA	NA	NA	NA
Parking Type	NA	NA	NA	NA	NA	NA	NA	NA	NA	NA	NA	NA	NA	NA	NA
Parking Width (ft)	NA	NA	NA	NA	NA	NA	NA	NA	NA	NA	NA	NA	NA	NA	NA
Sidewalk (ft)	10	NA	10	NA	10	10	NA	10	10	NA	10	NA	10	NA	NA
Bike Lane (ft)	NA	6	NA	6	NA	NA	6	NA	NA	6	NA	6	NA	6	NA
Ped Zone (ft)	NA	6	NA	6	NA	NA	5	NA	NA	5	NA	5	NA	6	6
Buffer (ft)	4.5	4.5	4.5	4.5	4.5	4.5	4.5	4.5	4.5	4.5	4.5	4.5	4.5	4.5	4.5
Default Target Speed (mph)	35														
Minimum Centerline Radius (ft)*	510														
Maximum Grade (%)	5														
Minimum Grade (%)	0.5														
Minimum Vertical Crest Curve (K)	29														
Minimum Vertical Sag Curve (K)	49														
Design Vehicle	WB-62														

*The minimum centerline radius is based on a 2% normal crown.

This table reflects minimum design criteria. Refer to subsequent sections in this chapter for additional guidance.

Table 3-4. Commerce/Mixed-Use Roadway Design Criteria (CMU)

	CMU-L1-T0-TWLT-P0-BSU	CMU-L1-T0-TWLT-P0-BLC	CMU-L1-T0-TWLT-PP-BSU	CMU-L1-TP-TWLT-PP-BSU	CMU-L1-TD-TWLT-P0-BLC	CMU-L2-T0-TWLT-P0-BSU	CMU-L1-T0-TWLT-PP-BLB	CMU-L2-T0-TWLT-P0-BLC	CMU-L1-TP-TWLT-PP-BLB	CMU-L1-TD-TWLT-PP-BLC	CMU-L2-T0-TWLT-PP-BSU	CMU-L1-T0-TWLT-PA-BSU	CMU-L1-T0-TWLT-PA-BLC	CMU-L2-TP-TWLT-PP-BSU	CMU-L2-TD-TWLT-P0-BLC	CMU-L2-T0-TWLT-PP-BLC
ROW (ft)	80	90	90	100	100	100	100	110	110	110	110	110	110	120	120	120
Lane Width (ft)	11	11	11	11	11	11	11	11	11	11	11	11	11	11	11	11
Outside Lane Width (ft)	11	NA	NA	NA	NA	11	NA	NA	NA	NA	NA	NA	NA	NA	NA	NA
Median Type	TWLT/ Island	TWLT/ Island	TWLT/ Island	TWLT/ Island	TWLT/ Island	TWLT/ Island	TWLT/ Island	TWLT/ Island	TWLT/ Island	TWLT/ Island	TWLT/ Island	TWLT/ Island	TWLT/ Island	TWLT/ Island	TWLT/ Island	TWLT/ Island
Median Width (ft)	11	11	11	11	11	11	11	11	11	11	11	11	11	11	11	11
Shared Lane Type	NA	NA	NA	Parking + Transit	Bike + Transit	NA	Bike + Parking	NA	Parking + Transit	Bike + Transit	NA	NA	Bike + Parking	Parking + Transit	Bike + Transit	Bike + Parking
Shared Lane Width (ft)	NA	NA	NA	11	11	NA	16	NA	11	11	NA	NA	16	11	11	16
Parking Type	NA	NA	Parallel	Shared	NA	NA	Shared	NA	Shared	Parallel	Parallel	Angle	Angle & Shared	Shared	NA	Shared
Parking Width (ft)	NA	NA	8	NA	NA	NA	NA	NA	NA	8	8	19	19	NA	NA	NA
Sidepath (ft)	NA	NA	NA	NA	NA	NA	NA	NA	NA	NA	NA	NA	NA	NA	NA	NA
Bike Lane (ft)	NA	NA	NA	NA	NA	NA	NA	NA	NA	NA	NA	NA	NA	NA	NA	NA
Ped Zone (ft)	6	6	6	6	6	6	6	6	5	6	6	6	6	6	6	5
Buffer (ft)	6.5	6.5	2.5	6.5	6.5	6.5	2.5	6.5	6	2.5	2.5	2.5	2.5	6.5	6.5	3
Default Target Speed (mph)	25															
Minimum Centerline Radius (ft)*	198															
Maximum Grade (%)	5															
Minimum Grade (%)	0.5															
Minimum Vertical Crest Curve (K)	12															
Minimum Vertical Sag Curve (K)	26															
Design Vehicle	BUS-40/Emergency Vehicle															

*The minimum centerline radius is based on a 2% normal crown.

This table reflects minimum design criteria. Refer to subsequent sections in this chapter for additional guidance.

Table 3-5. Activity Street Roadway Design Criteria (ACT)

	ACT-L1-T0-UNDIV-PP-BSU	ACT-L1-T0-NTMN-PP-BSU	ACT-L1-T0-TWLT-PP-BSU	ACT-L1-TP-UNDIV-PP-BSU	ACT-L1-TP-NTMN-PP-BSU	ACT-L1-T0-UNDIV-PP-BLC	ACT-L1-T0-TWLT-PP-BSU	ACT-L1-T0-UNDIV-PP-BSU	ACT-L1-TP-TWLT-PP-BSU	ACT-L1-TP-UNDIV-PP-BLB	ACT-L1-TD-UNDIV-PP-BLC	ACT-L1-T0-NTMN-PP-BLB	ACT-L1-T0-TWLT-PP-BLC	ACT-L2-T0-UNDIV-PA-BLC	ACT-L1-TD-NTMN-PP-BLC	ACT-L1-TP-NTMN-PP-BLB	ACT-L1-TP-TWLT-PP-BLB	ACT-L1-TD-TWLT-PP-BLC	ACT-L1-T0-TWLT-PP-BLB	ACT-L2-T0-TWLT-PP-BSU
ROW (ft)	80	80	80	90	90	90	90	90	100	100	100	100	100	100	100	110	110	110	110	110
Lane Width (ft)	11	11	11	11	11	11	11	11	11	11	11	11	11	11	11	11	11	11	11	11
Outside Lane Width (ft)	NA	NA	NA	NA	NA	NA	NA	NA	NA	NA	NA	NA	NA	NA	NA	NA	NA	NA	NA	NA
Median Type	NA	Narrow	TWLT/Island	NA	Narrow	NA	TWLT/Island	NA	TWLT/Island	NA	NA	Narrow	TWLT/Island	NA	Narrow	Narrow	TWLT/Island	TWLT/Island	TWLT/Island	TWLT/Island
Median Width (ft)	NA	6	10	NA	6	NA	10	NA	10	NA	NA	6	10	NA	6	6	10	10	10	10
Shared Lane Type	NA	NA	NA	Parking + Transit	Parking + Transit	Bike + Parking	NA	NA	Parking + Transit	Parking + Transit	Bike + Transit	NA	Bike + Parking	Bike + Parking	Bike + Transit	Parking + Transit	Parking + Transit	Bike + Transit	Bike + Parking	NA
Shared Lane Width (ft)	NA	NA	NA	11	11	16	NA	NA	11	11	11	NA	16	16	11	11	11	11	16	NA
Parking Type	Parallel	Parallel	Parallel	Shared	Shared	Shared	Angle & Parallel	Angle	Shared	Shared	Parallel	Parallel	Shared	Angle & Shared	Parallel	Shared	Shared	Parallel	Angle & Shared	Parallel
Parking Width (ft)	8	8	8	NA	NA	16	19 / 8	19	NA	NA	8	8	NA	19	8	NA	NA	8	19	8
Sidewalk (ft)	NA	NA	NA	NA	NA	NA	NA	NA	NA	NA	NA	NA	NA	NA	NA	NA	NA	NA	NA	NA
Bike Lane (ft)	NA	NA	NA	NA	NA	NA	NA	NA	NA	8	NA	8	NA	7	NA	8	8	NA	7	NA
Ped Zone (ft)	6	6	5	6	5	6	5	5	6	5	6	6	6	6	5	6	5	6	6	6
Buffer (ft)	2.5	2.5	2.5	6.5	6.5	2.5	2.5	2.5	6.5	6.5	2.5	2.5	2.5	2.5	3.5	6.5	6.5	2.5	2.5	2.5
Default Target Speed (mph)	25																			
Minimum Centerline Radius (ft)*	198																			
Maximum Grade (%)	5																			
Minimum Grade (%)	0.5																			
Minimum Vertical Crest Curve (K)	12																			
Minimum Vertical Sag Curve (K)	26																			
Design Vehicle	BUS-40/Emergency Vehicle																			

*The minimum centerline radius is based on a 2% normal crown.
 This table reflects minimum design criteria. Refer to subsequent sections in this chapter for additional guidance.

3.2 DESIGN CONTROLS

3.2.1 Design Speed/Target Speed

Design speed is the maximum speed at which the motor vehicle can safely travel on a roadway or street based on its horizontal and vertical geometry. There are other roadway elements that have bearing on design speed for the streets. The City uses target speed instead of design speed, which considers other street elements in addition to geometric elements to determine the appropriate speed for street design.

Target speed is the highest speed at which vehicles should operate on a street in a specific context, consistent with the level of multimodal activity generated by adjacent land uses to provide both mobility for motor vehicles and a safe environment for pedestrians and bicyclists. A slower target speed allows the use of features that enhance the pedestrian experience, such as smaller horizontal curve, shorter lane widths, on-street parking, curb extensions, and bike facilities.

3.2.1.1 Design Criteria

Table 3-6 summarizes target speeds based on street type. Both the target speed range and the default target speed shown below are based on the City's [MTP](#). The default target speed shall be used in the design of all roadway elements, including horizontal and vertical curvature, and should ultimately be the posted speed limit. Deviations from the default target speed are considered exceptions and can only occur within the ranges (if there are any) prescribed for each street type. These deviations must be approved by Transportation and Public Works (TPW) Department based on an engineering analysis that justifies the exception.

Table 3-6. Street Type Target Speeds (mph)

Street Type	Default Target Speed	Target Speed Range
System Link	40	35-45
Commercial Collector	35	30-35
Neighborhood Connector	35	30-35
Commerce/Mixed-Use Street	25	-
Activity Street	25	-
Standard Collectors	25	-
Industrial Collectors	25	-
Local Street	25	-

3.2.2 Design Volume

Traffic volumes are important for the design of a roadway facility. Facilities should have enough capacity to accommodate anticipated traffic volumes. These design volumes are usually projected into the future for a designated design year. The [MTP](#) uses the design volumes to assign the pavement width and target speed for each facility.

The latest edition of the AASHTO Green Book defines Average Daily Traffic (ADT) as:

- The total volume during a given time period (in whole days), greater than one day and less than one year, divided by the number of days in that time period.

3.2.2.1 Design Criteria

The MTP categorizes street types by land use and not traffic volumes. However, the MTP utilizes design volumes to assign right-of-way, number of lanes, median types, bicycle and transit facility types.

Table 3-7 summarizes the median, on-street parking, and bike facility treatment types based on ADT volumes (from the 2035 North Central Texas Council of Governments travel demand forecasting model used in the MTP) and the type of street.

Table 3-7. Street Type Treatments based on Average Daily Traffic (vpd)

Street Type	Median Type		On-Street Parking Type		Bike Facility Type	
System Link	>35,000 ³	Wide	None		**	
	<35,000 ³	Standard				
Commercial Connector	>15,000 ²	Standard	None		***	
	<15,000 ²	TWLT				
Neighborhood Connector	>15,000 ^{2*}	Standard	None		***	
	<15,000 ^{2*}	TWLT				
Commerce/Mixed-Use Street	**		See Activity Street		Same as Activity Street	
Activity Street	>5,000 ¹	TWLT	>20,000	None	>5,000	Shared Lane
	<5,000 ¹	Undivided	<20,000	Parallel	<5,000 and <25 mph target speed and not a trail connection	Conventional Bike Lane for streets with no parking; Buffered Bike Lane otherwise
			<5,000 ¹	Angle/Diagonal		
Standard Collectors	>2,500	TWLT	**		**	
Industrial Collectors	**		**		**	

^{1,2,3} = Only applies to roads with 1/2/3 lanes in each direction

* = For facility types that are not median running

** = Not dependent on traffic volumes

*** = Refer to MTP for bicycle facility types for Neighborhood Connector and Commercial Connector

Additional information on medians and on-street parking types can be found in the Medians and On-Street Parking and Curbside Use sections of this chapter. Refer to Chapter 4 for more information on bike treatments.

3.2.3 Stopping Sight Distance

Stopping sight distance is the minimum distance needed for a driver to be able to react and stop to an object or person on the roadway to avoid collision. It is the sum of two distances: (1) brake reaction distance and (2) braking distance. Brake reaction distance is the distance a vehicle travels from the time the driver sights an object to the time the brakes are applied, whereas braking distance is the distance required for the vehicle to stop after the brakes are applied. Stopping sight distance should be adequate at every point along a roadway for drivers to come to a safe stop before reaching an object.

3.2.3.1 Design Criteria

Based on the latest edition of the AASHTO Green Book, for stopping sight distances, the height of the driver's eye is 3.5 feet and the object height is 2.0 feet, which is equivalent to the taillight height of a passenger car. **Figure 3-1** shows an overview of stopping sight distance.

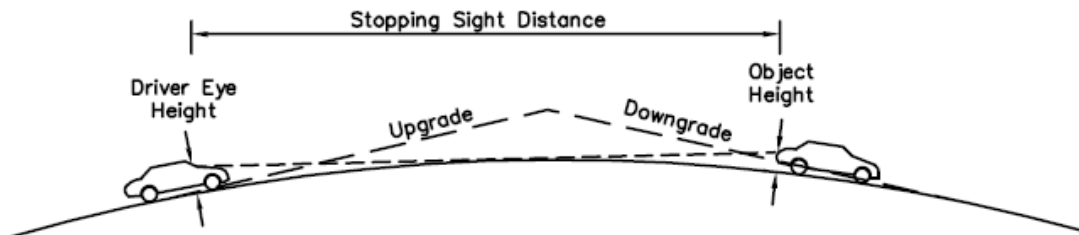

Figure 3-1. Stopping Sight Distance

Stopping Sight Distance (SSD) in feet is determined from the formula:

$$SSD = 1.47Vt + \frac{V^2}{30\left[\left(\frac{a}{32.2}\right) \pm G\right]}$$

Where:

V = target speed, mph

t = brake reaction time, 2.5 s

a = deceleration rate, ft./s²

G = grade, rise/run, ft./ft.

3.2.4 Horizontal Sight Distance

Horizontal Sight Distance is the distance across the inside of a horizontal curve that a driver can see before an obstruction (such as walls, cut slopes, buildings, and longitudinal barriers). For undivided highways, this is measured from the highway centerline whereas on divided highways, horizontal sight distance is measured from the centerline of the inside lane.

3.2.4.1 Design Criteria

Based on the latest edition of the AASHTO Green Book, the Horizontal Sight Line Offset (HSO) is determined by setting the value S equal to the stopping sign distance (SSD). **Figure 3-2** shows an overview of horizontal sight distance.

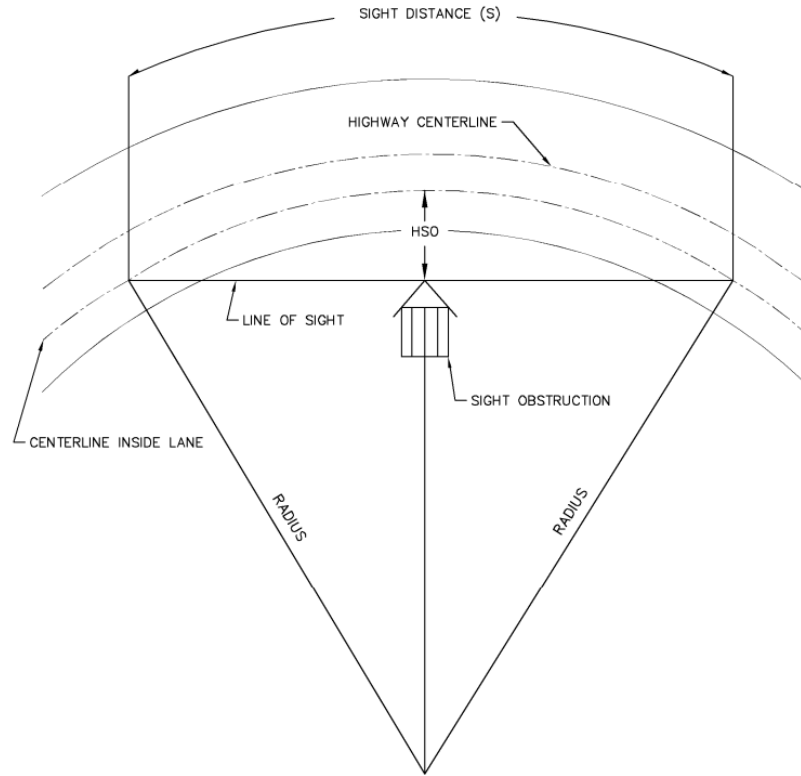

Figure 3-2. Horizontal Sight Distance

Horizontal Sight Distance, or Horizontal Sight Line Offset (HSO), in feet is determined from the formula:

$$HSO = R \left[1 - \cos \left(\frac{28.65S}{R} \right) \right]^*$$

Where:

HSO = Horizontal sight line offset, ft.

S = Sight distance, ft.

R = Radius of curve, ft.

* This equation only applies to circular curves longer than the sight distance of the pertinent design speed.

3.3 DESIGN ELEMENTS

3.3.1 Horizontal Alignment

Horizontal alignment of roadways consists of a combination of circular curves and tangents which are used to form smooth transitions from one roadway section to another. Criteria for determining the maximum allowable limits of curves are based on the laws of mechanics and factors such as superelevation and friction factors representative of pavement surfaces. The basic formula for determining horizontal alignment is:

$$e + f = \frac{V^2}{15R}$$

Where:

e = superelevation rate, in decimal format

f = side friction factor

V = vehicle speed, mph

R = curve radius, feet

3.3.1.1 Design Criteria

The minimum radius of a roadway is based on a standard of driver comfort that is appropriate to provide a margin of safety against vehicle rollover and skidding. For layout purposes, the radius is measured to the centerline of the alignment. Typically, the City will not use superelevation on a city street. Therefore, the minimum centerline radius shall be provided based on the normal crown section. **Table 3-8** shows the minimum radii based on a normal crown with no superelevation (-2%). Smaller radii may be used with the appropriate superelevation to maintain the target speed, if approved by the City Traffic Engineer. **Figure 3-3** shows the different horizontal curve variables.

Table 3-8. Minimum Radii for Low-Speed Urban Streets

Target Speed (mph)	Minimum Radius (ft)
25	198
30	333
35	510
40	762

Source: AASHTO Green Book (2018)

Horizontal alignment shall not be designed with a reverse curve without a tangent between two curves. The minimum tangent length between two reverse horizontal curves must be a minimum of 100 feet.

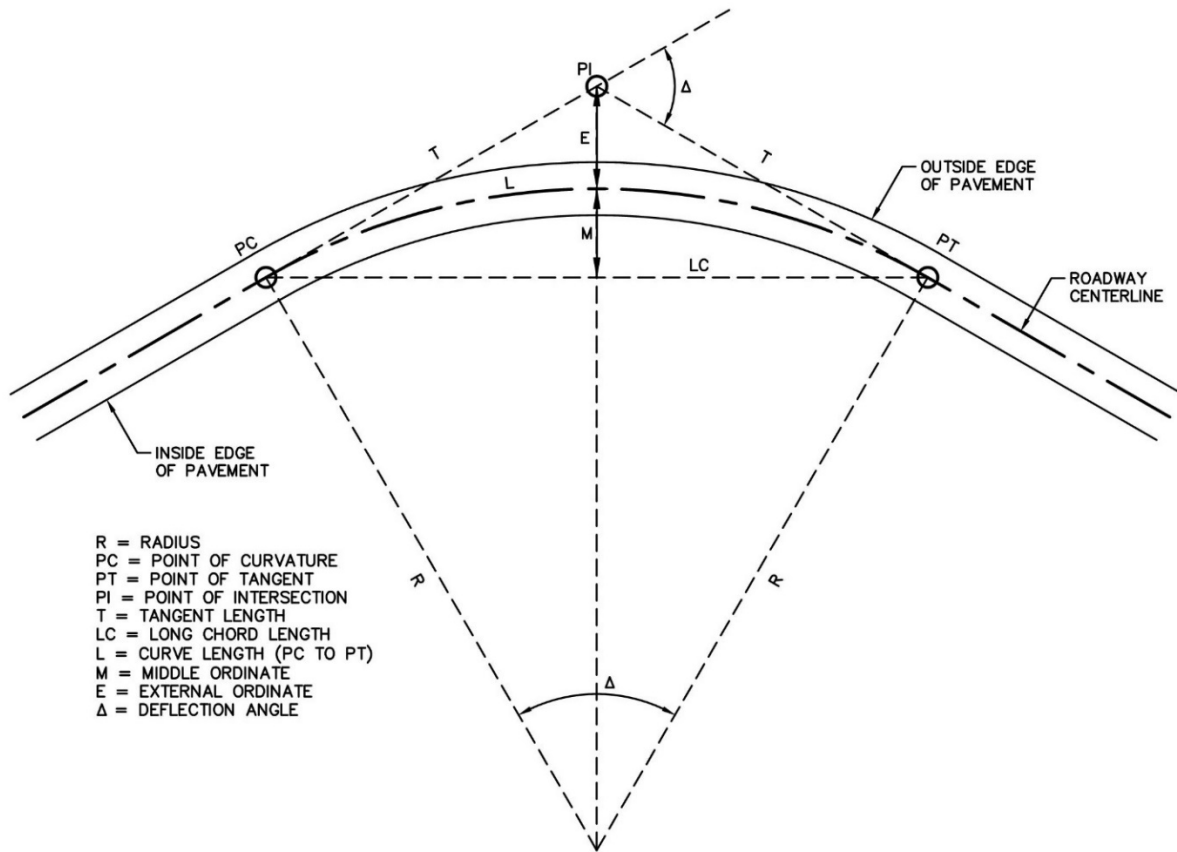

Figure 3-3. Horizontal Curve Variables

3.3.2 Vertical Alignment

Vertical alignment consists of combinations of straight sections, referred to as tangents or grades, and vertical curves.

3.3.2.1 Grades

Driving performance of vehicles with respect to grades varies greatly. Grades generally have a greater effect on the speeds of trucks than of passenger cars. Certain combinations of rate and length of grade cause trucks to decelerate to the point of constant critical or “crawl” speed. Maximum grades have been set relative to target speeds in recognition of such characteristics.

3.3.2.2 Vertical Curves

Vertical curves provide transitions between tangents of different grades. The significant terms used to describe profile points are shown in **Figure 3-4**. The first featured curve on the left of the figure is a sag vertical curve, and the second curve is a crest vertical curve. The minimum length for the vertical curve shall be 50 feet. Vertical curves may not be needed for a grade break of less than one percent.

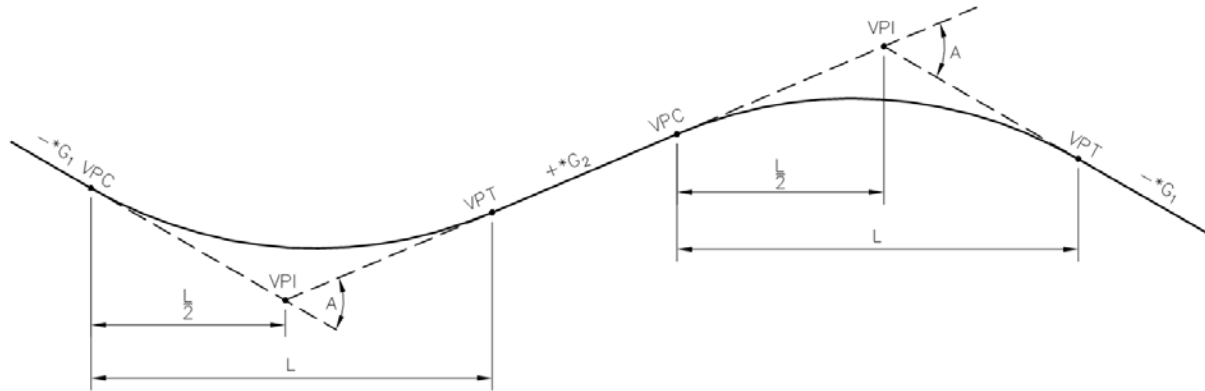

VPC = VERTICAL POINT OF CURVATURE (BEGIN CURVE)
 VPI = VERTICAL POINT OF PROJECTED GRADE LINE INTERSECTION
 VPT = VERTICAL POINT OF TANGENCY (END CURVE)
 G = TANGENT GRADE IN PERCENT
 L = LENGTH OF VERTICAL CURVE
 A = ALGEBRAIC DIFFERENCE IN GRADES

Figure 3-4. Vertical Curve Elements

The following parameters are also used:

- S = sight distance for crest vertical curves or headlight beam distance for sag vertical curves
- K = length of vertical curve per percent change in intersecting grades (A)

The basic formula for K is:

$$K = L/A$$

Crest Vertical Curves

The basic equations for length of a crest vertical curve needed to provide any specified value of sight distance are as follows:

When $S < L$,

$$L = \frac{AS^2}{100(\sqrt{2h_1} + \sqrt{2h_2})^2}$$

When $S > L$,

$$L = 2S - \frac{200(\sqrt{h_1} + \sqrt{h_2})^2}{A}$$

Where:

L = length of crest vertical curve, ft

A = algebraic difference in grades, percent

S = sight distance, ft

h_1 = height of eye above roadway surface, ft (3.5 ft for stopping sight distance)

h_2 = height of object above roadway surface, ft (2.0 ft for stopping sight distance)

Sag Vertical Curves

Different criteria are used for establishing lengths of sag vertical curves, including headlight sight distance, passenger comfort, drainage control, and aesthetics. The basic equations for length of a sag vertical curve needed to provide any specified value of sight distance are as follows:

When $S < L$,

$$L = \frac{AS^2}{200[2.0 + S(\tan 1^\circ)]}$$

When $S > L$,

$$L = 2S - \frac{200[2.0 + S(\tan 1^\circ)]}{A}$$

Where:

L = length of sag vertical curve, ft

A = algebraic difference in grades, percent

S = light beam distance, ft

Figure 3-6 shows the general layout of two types of sag vertical curves.

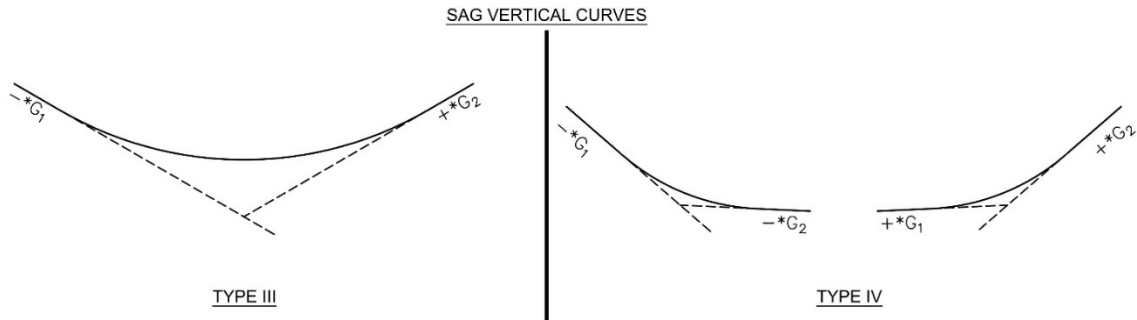

Figure 3-6. Sag Vertical Curve Types

The light beam distance should be approximately the same as the stopping sight distance. Table 3-10 shows the computed K values for lengths of sag vertical curves corresponding to the stopping sight distances for each target speed. Rounded values of K are used in design. Drainage criteria and minimum curve lengths are established similarly to crest vertical curves.

Table 3-10. Design Controls for Sag Vertical Curves

Target Speed (mph)	Stopping Sight Distance (ft)	Rate of Vertical Curvature, K	
		Calculated	Design
25	155	25.5	26
30	200	36.4	37
35	250	49.0	49
40	305	63.4	64

Source: Green Book (AASHTO, 2018)

3.3.3 Pavement Cross and Side Slopes

3.3.3.1 Pavement Cross Slopes

All thoroughfares shall be designed with a maximum cross-slope of 2%. The minimum cross-slope shall not be less than 1%. Superelevation is not permitted on the City's thoroughfares unless approved by the TPW.

3.3.3.2 Side Slopes

The maximum side slope allowed for the City's thoroughfares is 4H:1V. Retaining wall(s) will be required if side slopes are steeper than 4H:1V. If a temporary construction easement (TCE) or slope easement is required, coordinate with Real Property for requirements.

3.3.4 Pavement Transition

Pavement transitions, or tapers, are generally provided for widening and narrowing street cross sections to help guide users between changes in their normal driving path along a roadway. They are often used to transition from divided to undivided sections of roadway which are referred to as street cross-overs. Tapers are used in the narrowing or shifting of streets. Drivers follow these tapers with the use of channelizing devices and/or pavement markings.

The main types of tapers are defined below:

- **Merging Transition Taper.** The distance required for drivers to merge into an adjacent lane of traffic at the prevailing speed.
- **Shifting Transition Taper.** Transition taper used when a lateral shift is needed.
- **Shoulder Taper.** Used to direct traffic off the shoulder.
- **Downstream Taper.** Taper used to transition from a narrow roadway segment to a wider roadway segment.

The different types of tapers are shown in **Figure 3-7**.

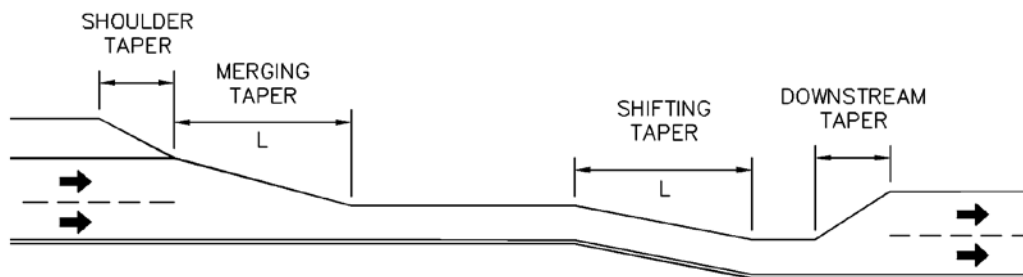

Figure 3-7. Pavement Transition Tapers

3.3.4.1 *Design Criteria*

Pavement transition design for permanent conditions shall be done in accordance with procedures outlined on the latest edition of the AASHTO Green Book. For a temporary condition, pavement transition shall be done in accordance with the [TMUTCD](#) or the latest guidelines. The appropriate target speed should be used to design the transition.

The following equations are used to calculate the transition length:

When target speed ≤ 40 mph:

$$L = \frac{WS^2}{60}$$

Where:

L = taper length in feet

W = width of offset in feet

S = target speed in mph

Table 3-11 shows the taper length criteria.

Table 3-11. Pavement Transition Length

Type of Transition	Length of Transition
Merging Taper	at least L
Shifting Taper	at least L
Shoulder Taper	at least 0.33 L
Downstream Taper	50 feet minimum, 100 feet maximum

Source: [TMUTCD](#) and *Green Book (AASHTO, 2018)*

3.3.4.2 *Guidance*

Longer tapers, especially in urban areas with short block lengths or driveways, can encourage drivers to delay lane changes, so they are not necessarily safer than shorter tapers.

Multiple merging tapers should have a tangent length of at least 2 taper lengths between them. Adjoining merging and shifting tapers should have a tangent length of at least 0.5 taper lengths between them.

If a shoulder is used as a travel lane, a normal merging or shifting taper should be used.

3.3.5 Signage and Pavement Markings

Signing and pavement markings are critical for safe and efficient operations of the roadway. Signing and pavement markings shall be provided in accordance with the latest edition of [TMUTCD](#) and the City's signage and pavement markings standard details.

3.3.5.1 *Street Name Sign Installation Policy*

It is the policy of the City to require installation of street name signs at all intersecting public streets. Intersections created by streets within a subdivision that intersect border streets shall also be considered intersections within a subdivision.

3.4 OTHER ELEMENTS

3.4.1 Roadway Drainage

Roadway drainage is designed based on the existing roadway geometry. Poor roadway drainage can cause many problems, including negative impacts to traffic safety, erosion, and reduced bearing capacity in the subgrade.

Refer to [City of Fort Worth iSWM](#) for stormwater design guidelines.

3.4.2 Public Right-of-Way Visibility Requirements

Adequate sight distance at the intersection of a street and another street, driveway, or alley must be provided to reduce potential conflicts. When determining whether an object constitutes as a sight obstruction within a sight triangle, consider both the horizontal and vertical alignment of the intersecting roadways and the height and position of the object. Visibility requirements shall be provided in accordance with Intersection Sight Distance as provided in **Chapter 6, Table 6-1**.

3.4.3 Street Lighting

The following policy shall govern all installations of street lights within the City limits and its ETJ. As used in this section, Director shall mean the Director of the Department of Transportation and Public Works, unless otherwise noted.

3.4.3.1 *General*

- The City Engineer shall approve the design, equipment and material that will be acceptable for all street light installations within the City of Fort Worth or its ETJ.
- All designs, plans, and specifications for installations of street lights shall be reviewed and approved by the Director. Requests for approval of designs other than the City's minimum standard design must include calculations demonstrating that the proposed design equals or exceeds the City's minimum standard design.

3.4.3.2 *Policy and Procedures*

Neighborhood Street Lighting on Residential and Local Streets

- Street lighting shall be installed:
 - At all intersections.
 - At the end of all culs-de-sac and dead-end streets longer than 200 feet.
 - At all significant changes in direction of the roadway, defined as those where, when standing in the center of the roadway at one street light, you cannot see the next street light due to horizontal or vertical changes in the roadway.
 - As necessary to achieve an approximate spacing between lights of 300 feet, except along schools, City parks, libraries, and community centers where the spacing will be reduced to 200 feet.
- The minimum standard design for residential and local streets shall consist of an LED equivalent to a 100-watt high pressure sodium vapor luminaire, mounted at a minimum 25-foot height above the roadway surface on a galvanized steel pole using underground wiring.

- Steel poles and underground wiring shall be used at all new developments.
- Decorative lighting is allowed, provided that a complete neighborhood is installed in the same manner and the number of lights is increased to compensate for the lower light levels, and mid-block lights will be placed approximately 150 feet apart.
- Any request to deviate from the above standards shall be accompanied with a report prepared by a professional engineer showing the roadway illumination. Any request to use non-standard poles and fixtures will also require the developer to enter into a separate maintenance agreement.

Street Lighting on Collector Streets

- Street lighting shall be installed:
 - At all intersections.
 - At all significant changes in directions, defined as those where, when standing in the center of the roadway at one street light, you cannot see the next street light due to horizontal or vertical changes in the roadway.
- The minimum standard design for collector streets shall consist of an LED equivalent to a 100-watt high pressure sodium vapor luminaire, mounted at a minimum 30 foot height above the roadway surface, on a galvanized steel pole using underground wiring.
- Steel poles and underground wiring shall be used at all new developments.

Street Lighting on Thoroughfare Streets

- Street lighting shall be designed for thoroughfares to meet the lighting criteria in the latest version of the Illuminating Engineering Society (IES) Roadway Lighting Report 8 and the latest version of the National Electric Code (NEC).
- The minimum standard design for thoroughfare streets shall consist of an LED equivalent to a 200-watt high pressure sodium vapor luminaire, mounted at a 38-foot height above the roadway surface on a galvanized steel pole, and minimum six (6) foot mast arm, using underground wiring at an approximate spacing of 200 feet apart.
- Any request to deviate from the above standards shall be accompanied with a report prepared by a professional engineer showing the roadway illumination. Any request to use non-standard poles and fixtures will also require the developer to enter into a separate maintenance agreement.

Street Lighting on Frontage/Service Roads

Street light installations on any frontage road, service road, or other roadway adjacent to an Interstate Highway, U.S. Highway, or State Highway will be determined by the Director subject to the approval of the Texas Department of Transportation (TxDOT) on an individual basis according to current standards for roadway lighting.

3.4.3.3 Engineering

- All street lighting installations shall be in accordance with design criteria and standard construction details. Where there is a question as to equipment required, it shall be resolved in favor of additional street lighting.

- Existing utility poles, where available at specific locations, and overhead wiring may be used under certain circumstances, subject to approval of the Director.
- The developer shall furnish, at his sole expense, an exhibit at a standard engineering scale and a cost estimate together with submittal of the request for a developer's contract. For phased developments, the developer shall submit an exhibit at a standard engineering scale showing the total development.
- The developer shall submit construction plan sheets and standard construction details of all street lighting sealed by a professional engineer as part of the construction.
- The developer shall provide all necessary utility easements required for the street lighting system on the final plat.

3.4.3.4 *Construction*

- The developer is responsible for installing the street light system and will be expected to provide poles, fixtures, and mast arms approved by the City.
- There will be a fee for City street light crews to install final taps to the local utilities transformers and hand holes.
- All street lighting shall be owned by the City of Fort Worth.
- Street lights along private streets shall be installed by a contractor employed by the developer.

3.4.3.5 *Financial Responsibility*

The developer is responsible for 100% of the cost for installation.

3.4.3.6 *Ownership and Maintenance*

All street lights installed in a dedicated public right-of-way shall become the property of the City upon final acceptance of a project. No private utility company ownership of street lights shall be allowed. Unless otherwise provided for under a separate maintenance agreement, all street lights installed pursuant to this section shall be maintained by City.

3.4.3.7 *Special Districts*

There are several districts within the City that have pre-established street lighting design guideline and standards. These design standards supersede those established in this section. These districts include:

- Downtown Central Business District
- Near Southside

3.4.4 Medians

Medians are the portion of a divided street used to separate opposing lanes of traffic. Medians can be raised, depressed, or flush (pavement markings). Medians are typically longer and more continuous than islands. Medians provide better access management by limiting vehicle turn movements across the traveled way. This increases safety by reducing the number of conflict points and providing an extra buffer between opposing lanes of traffic. Medians also provide refuge for pedestrians crossing the street and offer additional space for landscaping, lighting, and placement of utilities. Landscaped medians enhance the aesthetics of the surrounding environment and contribute to the character of a community. The [Access Management Policy](#) details requirements on the installation and spacing of median openings and providing for u-turn movements.

3.4.4.1 Types

Based on the [MTP](#), median types include two-way left-turn lanes, narrow, standard, wide, and transit medians. The [MTP](#) sets the median type and width on non-established thoroughfares. **Figure 3-8** shows the median types and widths.

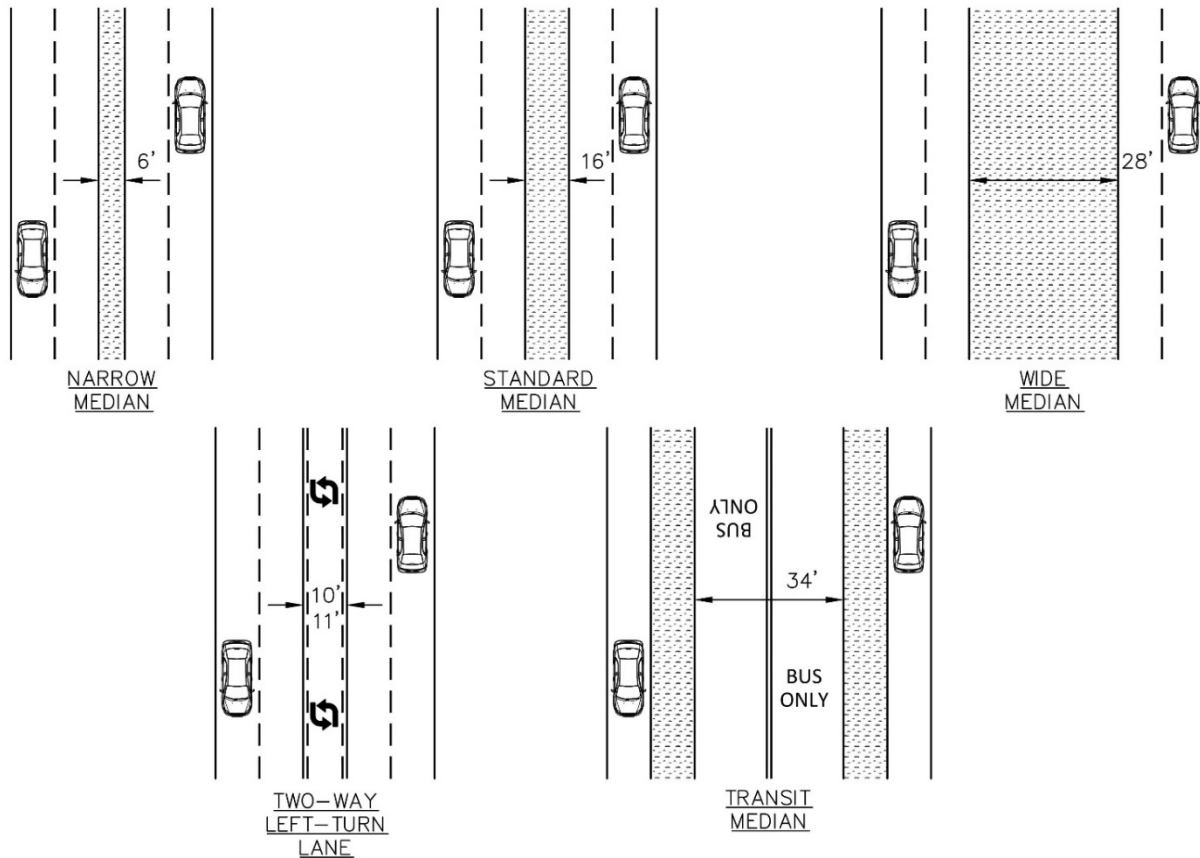

Figure 3-8. Median Types

Non-Traversable Medians

Non-traversable medians constitute vertical barriers between directions of travel. Typically, medians are raised. Landscaping, especially vertical features such as trees and taller shrubs close to the travel way, is an important element of a Complete Streets approach to calming traffic. Medians typically have openings at intersections and major driveways.

- **Standard Median.** Standard medians provide the dual function of controlling access between intersections and accommodating single left-turn lanes at intersections. Note that corridors with standard medians may contain intersections that need dual left-turn lanes.
- **Wide Median.** Wide medians are included for corridors on which dual left-turn lanes are expected to be prevalent.
- **Narrow Median.** Narrow medians are an option for where volumes are low and/or left-turning needs are minimal. They can be used on single-lane roundabout corridors where turns (including U-turns) often occur. They are also used to provide aesthetics and traffic calming on a roadway with fairly low turning volumes.
- **Transit Median.** Transit medians are intended to accommodate either dedicated bus lanes or center-running light-rail transit – one transit vehicle in each direction running within the median. Additional width is included on both outside edges of these medians for two purposes: (a) to provide a platform area for waiting transit passengers at stops, and (b) to shadow left-turn lanes at intersections. Transit medians are provided on Street Types that offer the needed width and generally have the level of access management needed to promote high capacity transit usage of the median.

Depressed Median

Any of the non-traversable median options, except the narrow option, are candidates for consideration for a depressed, rather than raised, configuration in the appropriate circumstances. Depressed medians are often used for Stormwater management purposes, in keeping with Green Infrastructure practices supported by the City. Refer to the [MTP](#) for further guidance.

Two-Way Left-Turn Lane (TWLTL)

A two-way left-turn lane (TWLTL) consists of a striped center lane from which left turns can be made by vehicles in either direction. TWLTLs maximize access to adjacent land uses, while promoting capacity by removing left-turn movements from the through travel stream. Portions of the lane can also include non-traversable medians to provide pedestrian refuge or to prevent turns at higher volumes/speeds.

3.4.4.2 Design Criteria

Refer to the [MTP](#) for the type of median and width.

On established thoroughfares, the width available will not include all cross-section elements called for in the Typical Section Selection flow-chart. In some cases, median design can be modified according to the Established Thoroughfare section of the [MTP](#).

3.4.5 On-Street Parking

On-street parking accommodates adjacent developments, separates pedestrians from moving traffic, and helps slow down through traffic. The two main types of on-street parking facilities are parallel parking spaces and angle/diagonal parking spaces.

3.4.5.1 *Types of On-Street Parking*

Figure 3-9 shows an overview of the main on-street parking types.

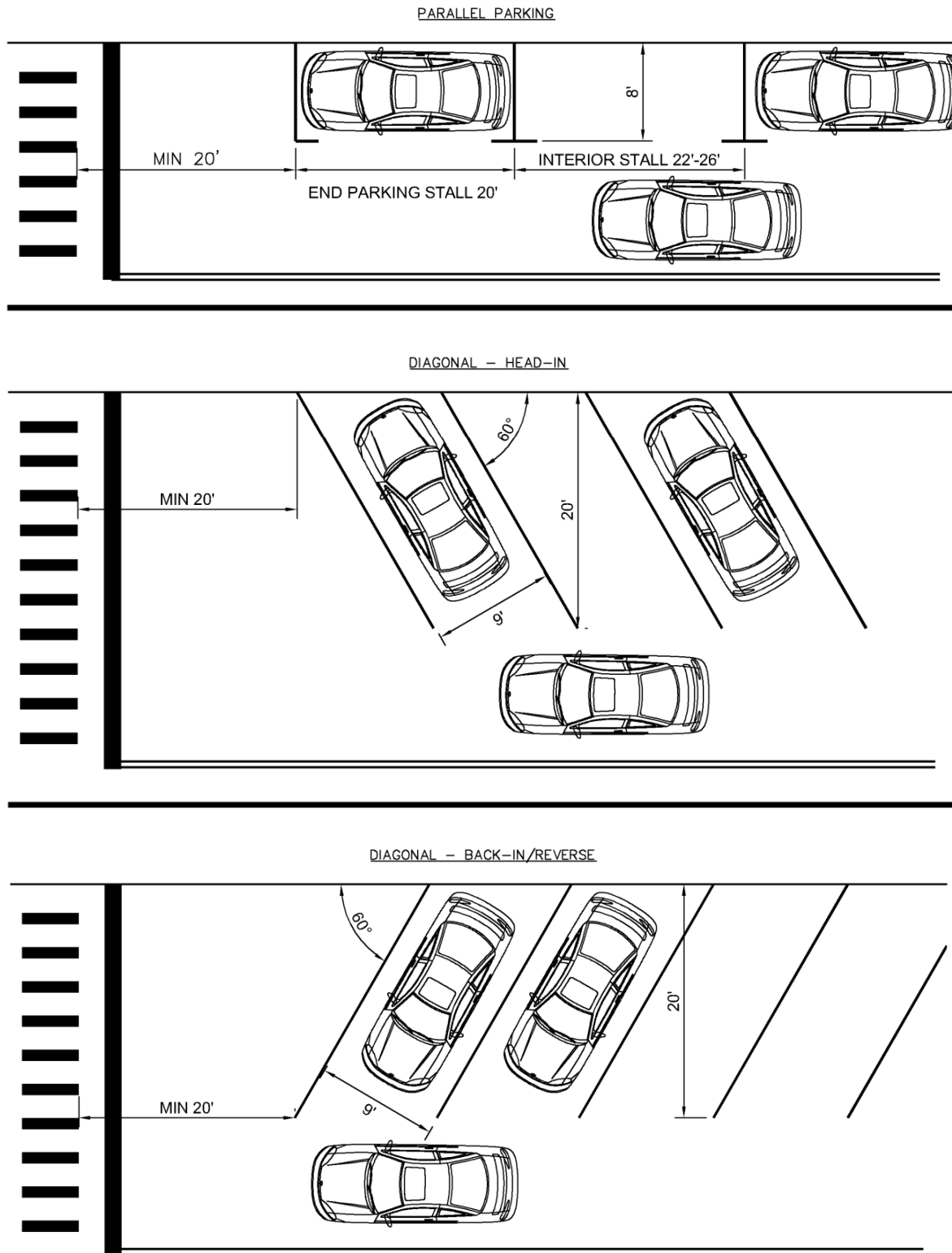

Figure 3-9. On Street Parking Types

Parallel Parking Areas

Parallel parking areas are incorporated into the parkway. They narrow the in-street cross-section and may be accompanied by regularly spaced curb bulb-outs.

Angle/Diagonal Parking Areas

The width is the same for both head-in and reverse/back-in angle parking. If adjacent to bike lanes, reverse angle parking shall be used. Bulb-outs/tree wells should be used with angle parking to narrow the effective street width and calm traffic. Shorter bulb-out areas can provide a motorcycle parking opportunity. Angle parking is not used on streets with one automobile through lane in each direction plus a median, because the median would hamper parking access. It is also not used on streets with more than one automobile through lane per direction.

Asymmetrical Parking

Different parking types can be used on both sides of a road to minimize cross-section width. Traffic calming can still be implemented by alternating, on a block-by-block basis, which side has the angle parking.

3.4.5.2 Design Criteria

All Activity Street sections, special residential sections, standard and industrial collectors, and many of the Commerce/Mixed-Use Street sections include on-street parking. Minimum, maximum, and preferred widths of on-street parking lanes can be found in the [MTP](#).

3.4.5.3 Guidance

No on-street parking is allowed beyond clustered on-street areas where additional width is supplied for parking stalls on limited local streets. Standard local streets are designed to accommodate parking on both sides which helps lower traffic speeds in neighborhood.

Parking stalls may be marked in commercial areas to delineate the travel space from the parking spaces. Markings also provide better guidance on the number and availability of spaces along the curbside.

For angled parking, reverse-in angle parking should be considered before front-in angle parking. Front-in parking is disadvantageous due to limited visibility. Motorists have a better view of the travel way and any crossing bicyclists when coming out of reverse-in angle parking. No bike lane behind head-in parking will be allowed.

Park assist lanes should be considered where appropriate. Park assist lanes are approximately 3 feet in width and are placed between the parking lanes and travel way. These lanes provide a buffer to the main travel way so that motorists feel safer while entering and exiting a parking lane on a busy street. If right-of-way is constricted, bike lanes can also act as this buffer. The space taken by the park assist lane can also make the travel way feel narrower, which reduces vehicle speeds and creates an even safer and more comfortable environment for parking maneuvers.

The [MTP](#) discusses other curbside parking uses noted below:

- Transit lanes located curbside can serve on-street parking during off-peak periods.
- Buffered bike lanes can be placed on either side of on-street parking depending on the amount of foot traffic and the long-term status of the on-street parking.

- Parallel parking areas can be used as loading zones and taxi stands when needed. Loading zones are typically used to accommodate buses, taxis, and commercial vehicles.

3.4.6 Access Management

3.4.6.1 Driveway Spacing

Driveway spacing is critical element of access management. Closely spaced driveways can create operational and safety issues at the street. The driveway spacing for various street types shall be provided in accordance with the City's [Access Management Policy](#). Refer to **Chapter 8** of this manual for spacing diagrams.

3.4.6.2 Lining Up Driveways across Roadways

Closely spaced driveways on opposite sides of a roadway may cause safety issues, as vehicles may make a “jog maneuver” to get across the roadway without making two separate turns. Along roadways with two-way left turn lanes, closely spaced driveways may result in left turns overlapping in the center lane, increasing the likelihood of head-on collisions. Regarding driveway spacing across roadways, the minimum spacing (based on speed) as shown in **Table 3-12** applies when driveways are not located directly across the roadway from each other.

Table 3-12. Minimum Offset for Driveways on Opposite Sides of a Roadway

Target Speed (mph)	Offset (ft)
≤30	175
35	330
40	660

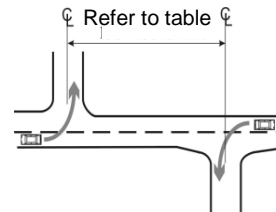

3.4.6.3 Angle of Intersection to the TxDOT Roadway

Access Management on TxDOT roadways maintained by the City should be done in accordance with [TxDOT Access Management Manual](#). For such roadways, the angle of the driveway from the highway pavement must be 75 to 90 degrees. Along one-way frontage roads or divided highways, an angle of 45 to 90 degrees is permitted. These driveway angles are shown in **Figure 3-10**.

While this is a requirement along TxDOT highways and frontage roads, all new driveways intersecting thoroughfares and collector streets must follow this standard and must still be approved by the City.

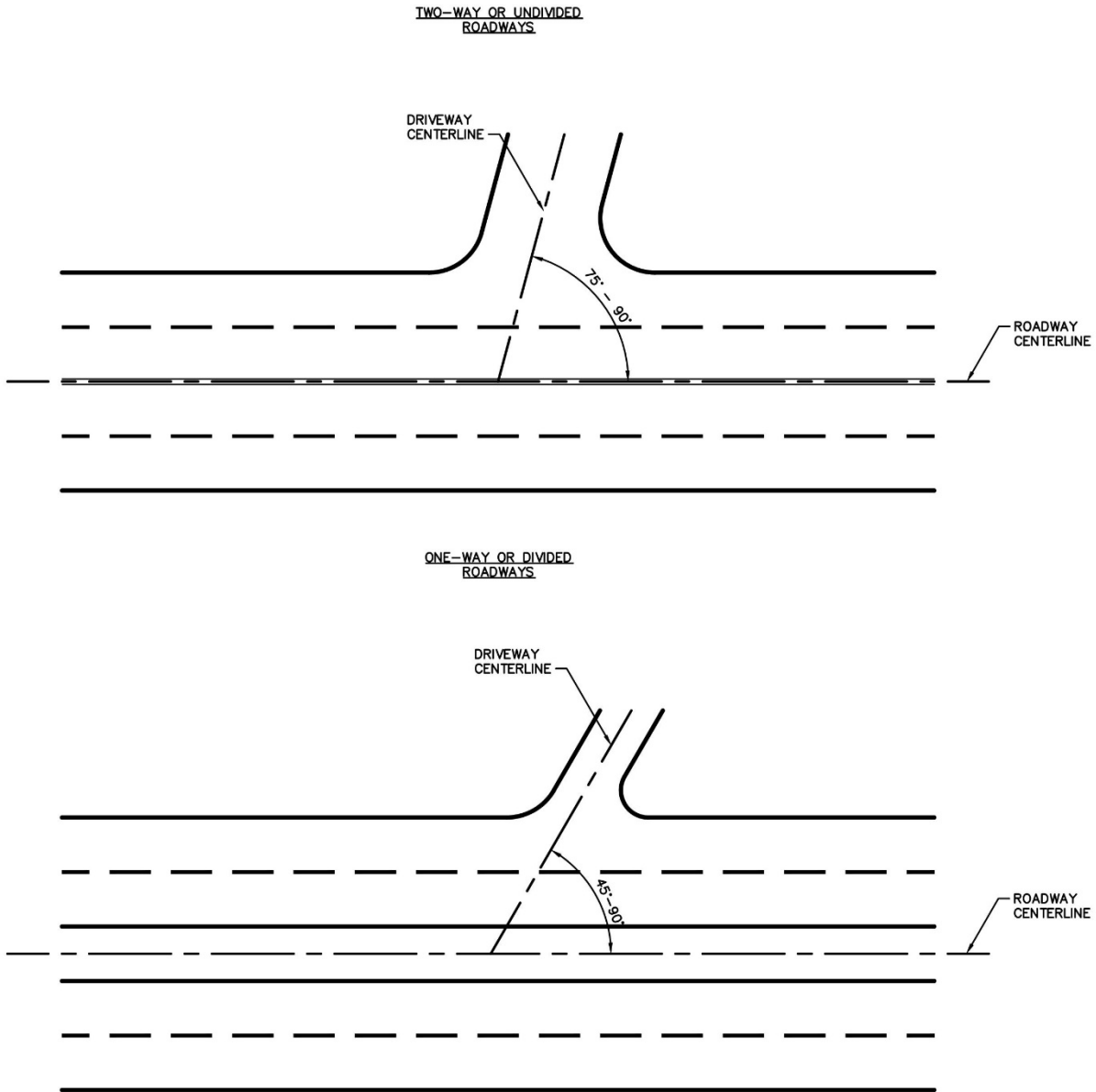

Figure 3-10. Driveway Angle

3.4.6.4 *Driveways and Accommodation of Pedestrians*

All driveways must be designed to safely accommodate pedestrians using sidewalks or paths. The following considerations must be made when accommodating pedestrian crossings at driveways:

- Crosswalk and ramp locations must be placed to balance the pedestrian crossing distance and the width of the intersection for vehicular traffic (typically this is at about the center point of the corner radius).

- Crosswalks must not be placed where pedestrians would likely have to cross behind or between stopped vehicles, except at roundabouts and “pork chop” right-turn islands.
- Where four or more driveway lanes are created, they must be designed so that the pedestrians have a refuge between the entering and exiting traffic.
- Horizontal and vertical alignments must provide an adequate advance view of the driveway intersection.
- Obstructions that block needed sight lines must be avoided.
- The [Texas Accessibility Standards \(TAS\)](#) specify a pedestrian travel path with a cross slope that does not exceed 2%.
- The sidewalk alignment across the driveway must be straight and not have steps or other abrupt changes in vertical elevation.

3.4.6.5 *Driveways and Accommodation of Bicycles*

Different City streets may carry bicyclists on sidepaths, in separated bike lanes, in on-street bike lanes, or in mixed traffic. Safely navigating a bicycle across a driveway largely depends on visibility, driver expectations, and sometimes bicyclist skill levels. Where a new driveway crosses a bicycle facility (such as a sidepath or an on-street bike lane), the driveway must be designed to accommodate the safe crossing of cyclists. Likewise, when a new bicycle facility is built that crosses existing driveways, the bicycle facility must be designed with safe crossings in mind. The following design considerations must be made when designing driveways to accommodate bicycle crossings:

- Provide horizontal and vertical alignment that allows an adequate advance view of the driveway intersection.
- Avoid obstructions that block needed sight lines for driver.
- Where a sidepath or sidewalk-level separated bike lane crosses a driveway, do not have an abrupt change where the bikeway cross slope meets the driveway grade.
- Where a bicyclist could turn into or turn out of a driveway, avoid designing abrupt changes in surface elevation that could create bumps for the bicyclist.
- Avoid grate openings that a bicycle tire could drop into.
- Provide a bicycle stopping sight distance on object heights of 0 inches to recognize any impediments on the pavement surface.
- Include warning signage at driveways that have two-way traffic present (for sidepath).

3.4.6.6 *Vehicle Stacking at Gates*

- For small infill projects of 40 residential units or less, there must be a minimum 16-foot stacking distance between the gate and travel lane.
- For infill projects of over 40 residential units, there must be a minimum 32-foot stacking distance, with applicable turnaround space, between the gate and travel lane.

Stacking can cross sidewalk, parkway, on-street parking zone and/or slip lane. Stacking must not be on a major thoroughfare as defined in the [MTP](#).

3.4.7 Complete Street Components

The key principles for consideration in the design of complete streets are outlined below:

- **Design for all users.** Young and old, pedestrians, automobiles, bicyclists, persons with disabilities, transit riders, and commercial vehicles. The design should consider the comfort level and needs of the different groups of users.
- **Design for safety.** Safety should be of the utmost importance, especially when considering vulnerable users like children, the elderly, and persons with disabilities. Street users should be able to easily cross the street, walk between restaurants or transit stations, or bike across. Consider altering the geometric design or operations to improve safety.
- **Use context-sensitive design solutions.** Not all streets are the same. Consider the needs and goals of each street individually before looking at the bigger picture to ensure that the design is appropriate. Build in some flexibility to accommodate changing needs. Design using the appropriate speed since the speed of vehicles impacts all users of the street.
- **Include environmentally sustainable solutions when possible.** Environmentally friendly design solutions can reduce congestion, promote alternative transportation methods, and improve air quality.
- **Design streets that enhance the public realm.** Streets should serve a bigger purpose than merely moving traffic. Consider designs and aesthetics that will improve the quality of place and add to the character of the surrounding areas.

3.4.8 Right-Sized Roadways

Right-sized roadways are facilities in which the effective street width and/or the number of motor vehicle travel lanes is reduced to better serve its full range of users. The space is then redefined for other purposes like landscaping, bike lanes, shoulders, transit uses, off-street parking spaces, and/or sidewalks. **Figure 3-11** shows a couple of examples before and after implementing the right-sized roadway approach. This traffic calming process is sometimes referred to as “roadway reconfiguration” or “road dieting.”

[Right-sized roadways](#) can have many benefits. FHWA highlights some of the benefits to the implementation of right-sized roadways including:

- Reduction in crashes from fewer vehicle-vehicle conflicts
- Reduced delays if adding a two-way left-turn lane to a previously undivided roadway
- Reduced crossing width for pedestrians
- Reduction of speed differentials, which causes fewer and less severe crashes
- Reduction in side-street delay due to crossing fewer lanes

- The addition of a pedestrian refuge island, a raised island that separates vehicles from pedestrians in the middle of the road way, makes crossing less complicated and safer for pedestrians.
- On-street parking spacing creates an additional buffer between moving vehicles and pedestrians.
- Adding painted bike lane pavement markings or bike lanes with a physical barrier makes bicyclists more visible to motorists, increases comfort for bicyclists, reduces vehicle speeds since drivers are more aware, and can even encourage bike usage.
- Improve the quality of life by increasing the comfort level of all users.

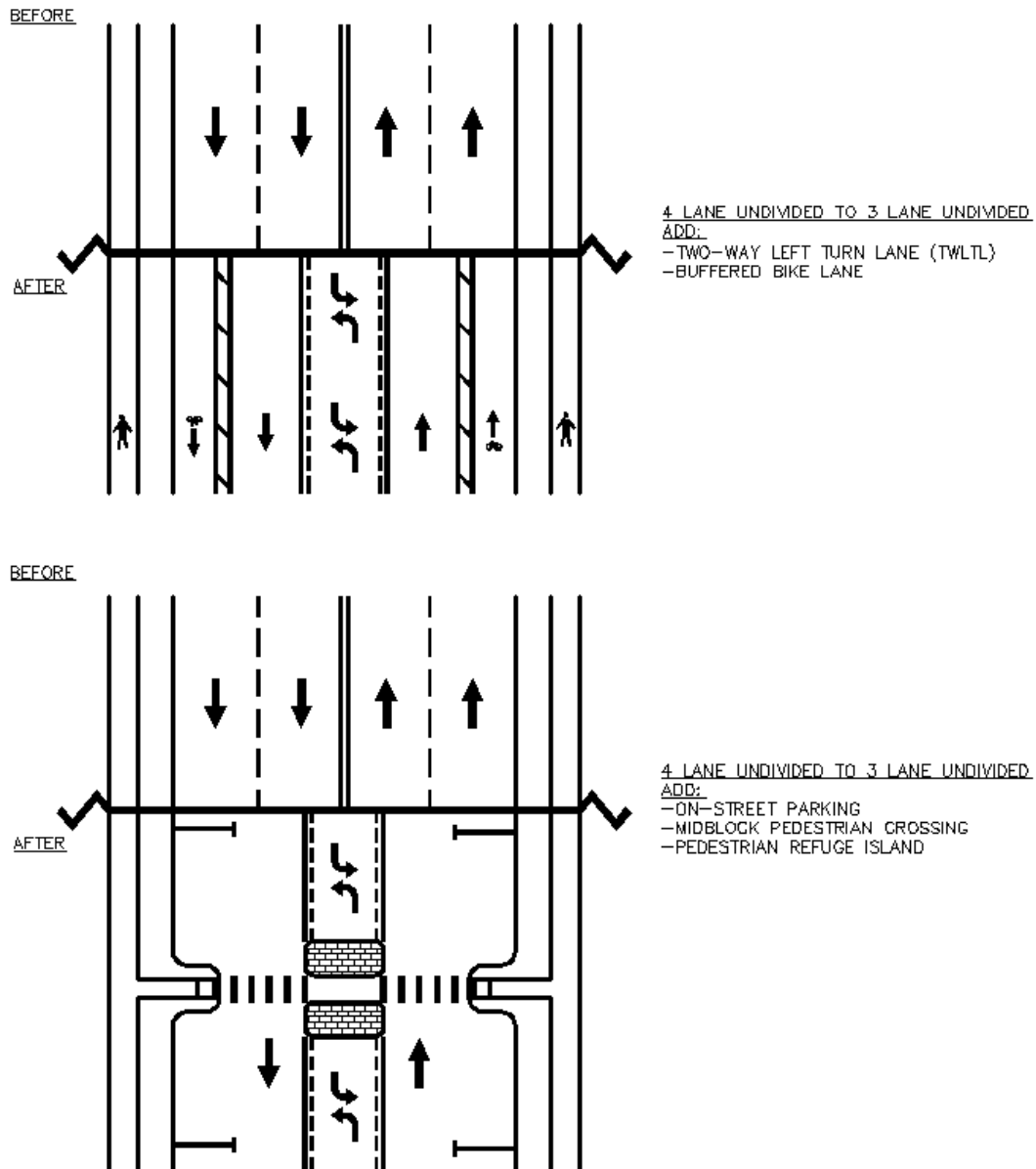

Figure 3-11. Right-Sized Roadway Retrofit Examples

3.4.8.1 *Design Criteria*

Table 3-13 provides right-sized roadway recommendations based on the existing number of lanes and ADT.

Table 3-13. Implementation of Right-Sized Roadways

Existing Number of Lanes	ADT (vpd)	Recommendation
4	<15,000	Generally good candidates for three lane conversion
4	15,000 – 20,000	May be good candidates for three lane conversion; Further traffic analysis needed
6	<35,000	May be good candidates for five lane conversion; Further traffic analysis needed

3.4.8.2 *Guidance*

The most common right-sizing configuration involves converting a four-lane road to three lanes: two travel lanes with a two-way left turn lane in the center of the roadway. The center turn lane at intersections often provides a great benefit to traffic congestion. A three-lane configuration with one lane in each direction and a center two-way left turn lane is often as productive (or more productive) than a four-lane configuration with two lanes in each direction and no dedicated turn lane. This addition of a center lane can lead to many benefits:

- Discourages speeding and weaving.
- Reduces the potential for rear end and side swipe collisions.
- Improves sight distances for left-turning vehicles.
- Reduces pedestrian crossing distances and exposure to motor vehicle traffic.

The space gained for a center turn lane is often supplemented with pavement markings, textured, or raised center islands. If considered during reconstruction, raised center islands may be incorporated in between intersections to provide improved pedestrian crossings, incorporate landscape elements, and reduce travel speeds. Reference the [MTP](#) for median width ranges on established thoroughfares.

3.4.9 Established Thoroughfares

The [MTP](#) states that established thoroughfares are typically not expected to increase in right-of-way or roadway width, because they are often constrained by existing development. If cross-sections are to be modified or added, the table in the [MTP](#) indicates the minimum, maximum, and desirable widths of the various elements. It should be noted that Special Districts may have differing ranges, and thus those standards should be consulted when appropriate.

Often, the width available on an Established Thoroughfare will not accommodate all cross-section elements called for by the [MTP](#) Typical Section flow-chart, given the minimum widths presented in the [MTP](#) table. In these cases, some elements may have to be sacrificed. Guidance on prioritizing elements can be found in the Established Thoroughfares section of the [MTP](#).

3.4.10 Air Rights

Air rights involve developing the air space over urban street or railroad corridors. This can help promote sustainable revitalization and provides opportunities to elevate walkways to reduce at-grade conflicts. Air rights development should be context sensitive and consider construction feasibility and costs. Air rights development can be complex and requires special planning and policy.

3.5 DESIGN CRITERIA FOR OTHER ROAD CLASSIFICATIONS

3.5.1 Alleys and Alleyway Turnouts

An alley is a narrow access way, often without sidewalks, that provides access to the back of buildings or garages. Alleys are often used for deliveries and garbage collection.

3.5.1.1 Design Criteria

Alley and alleyway turnout design standards can be found in the [Subdivision Ordinance](#) and are also shown below.

Length

Alleys shall be of a similar length as their associated opposite and parallel primary service streets, except for any additional length required for turnout returns to the primary service street. Dead-end alleys are prohibited. An alley with only one outlet shall be provided with an approved turn-around.

Width

Table 3-14 shows the design criteria for alleys and alleyway turnouts.

Table 3-14. Alley and Alleyway Turnout Design Criteria

	Single Family & Two-Family Subdivision (ft)	Multi-Family & Non-Residential Subdivisions (ft)
Right-of-Way	16	20
Roadway Paving	12	20
Right-of-Way Radius Street/Alley	25	25
Right-of-Way Radius Property Line	25	25

Paving

Alleys shall be paved with concrete in accordance with City's [Subdivision Ordinance](#) design standards and specifications. Alley paving shall have a minimum grade of 0.5% and a maximum grade of 10%.

Intersection with Streets

Alleys shall intersect streets at right angles or radial to curved streets. The intersection of a street and an alley shall be constructed as a standard driveway approach. Entrance widths to alleys shall be constructed 12 feet wide for one-family and two-family residential areas and 20 feet wide for other areas, with a uniform transition in alley pavement width not to exceed one foot of

transition per 20 feet in alley length. Requirements for spacing are included in the City’s [Access Management Policy](#).

Alleyway Turnouts

Alley turnouts shall be paved to the property line with turnouts to be not less than 20 feet wide as shown in **Figure 3-12**. At alleyway turnouts, the distance from the alley right-of-way to any gate, building or garage opening shall be at least 25 feet. In cases where two alleys intersect or turn at a sharp angle, lot corners shall be platted so that a triangular area of 25 feet by 25 feet or greater is dedicated as part of the alley for providing a minimum required radius of 30 feet to the inside edge of the alley paving.

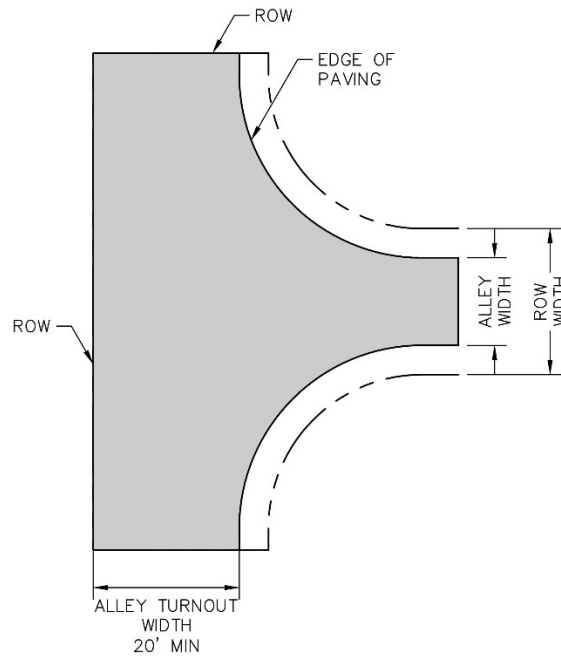

Figure 3-12. Alley Turnouts

3.5.2 Driveways

Driveways provide vehicular access between a public roadway and an adjacent property. The frequency and width of driveways can impact the safety and flow of traffic on the roadway. The need to access properties should be balanced with the potential for conflicts with pedestrians, bicyclists, and other motorized users. Driveways also reduce the amount of space available for on-street parking, so this trade-off should also be considered. **Figure 3-13** depicts the different driveway variables.

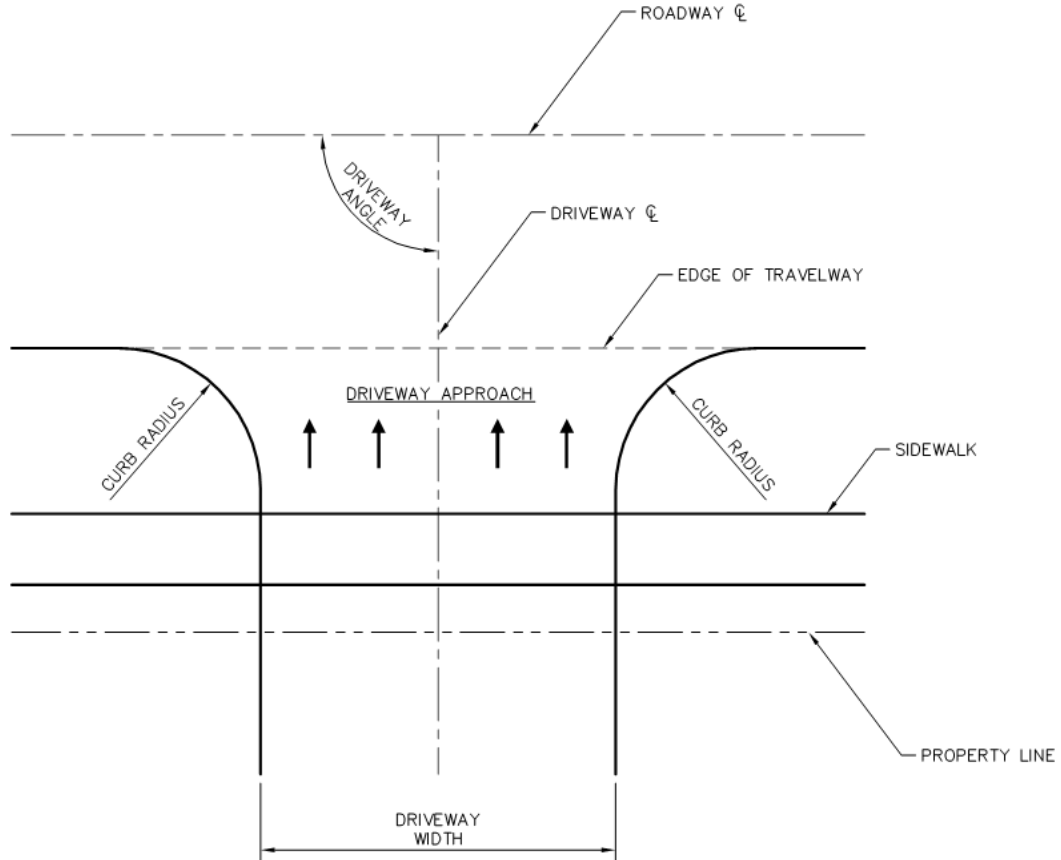

Figure 3-13. Driveway Variables

3.5.2.1 Classifications

Driveways are classified by their operational characteristics (one-way or two-way) and by the type of land use being served. In Fort Worth, all driveways are classified as either residential or commercial. Refer to City construction details for more information on various driveway configurations.

- Residential Driveways.** Provide access to residential properties containing single-family or duplex units. Permits for the construction of residential driveways must be obtained from the Construction Engineering Section of the TPW Department.
- Commercial Driveways.** Provide access to all other facilities, including offices, businesses, institutional buildings, shopping centers, multi-family housing, industrial parks and warehouses. Requests for commercial driveways must be approved by the City Traffic Engineer either (1) for a new development or (2) to change an existing driveway or construct a new one. After approval, the applicant must obtain a driveway construction permit from the Construction Engineering Section of the TPW Department. Spacing of commercial drives shall comply with the City's [Access Management Policy](#).

3.5.2.2 Location and Spacing

Refer to the City's [Access Management Policy](#) for location and spacing requirements of driveways.

3.5.2.3 *Design Criteria*

- The throat length is defined in the [Access Management Policy](#).
- The driveway angle can depend on whether the street is one-way or two-way and if left turns are permitted.
- Minimum sight distance shall be provided at all access points.
- Driveway approach shall have a maximum slope of 12% for residential driveways and 6% for commercial driveways. The grade break between street and driveway approach shall be maximum of 14% and 8%, respectively. The design of the driveway shall meet both criteria.
- Tapered or channelized deceleration lanes for vehicles turning right into high volume or intersection type driveways may be required on major streets.
- The use of one-way driveways, supported by an appropriate internal circulation system, is encouraged so that entrances and exits can function as separate driveways.
- The use of shared driveways outlined in Chapter V of the City's [Access Management Policy](#).
- For small-lot infill projects with a 10,000 square foot maximum lot size, a minimum driveway width of 10 feet and at most 10 parking spaces are required. If driveway access is from a major arterial as defined in the MTP, the project must meet fire requirements.

3.5.2.4 *Review/Exceptions Process*

Refer to the City's [Access Management Policy](#) for access management review/exceptions process.

3.5.2.5 *Restrictive Provisions*

Access to public streets will not be approved where the conditions described below restrict or compromise safety and efficiency:

- Access points shall not be approved for parking or loading areas that require backing maneuvers in a public street right-of-way except for single family or duplex residential uses on local streets.
- If a property has frontage on more than one street, access will be permitted only on those street frontages where standards can be met. If not possible, access points shall be designated based on traffic safety, operational needs, and conformance to as much of the requirements of these guidelines as possible.

3.5.3 **Dead-End Streets and Culs-De-Sac**

A cul-de-sac is an urban local street with only one outlet to another street, with the opposite end of the street terminated by a vehicular turn-around. Similar to a cul-de-sac, a dead-end street has the same general geometric aspects. However, the terminating end of the facility is more abrupt and undefined. Dead-end streets and culs-de-sac should be avoided if possible to enhance the street connectivity.

3.5.3.1 Design Criteria

Both dead-end streets and cul-de-sacs fall under the same design standards, as defined by the [Subdivision Ordinance](#), and are given in **Table 3-15**. **Figure 3-14** shows the geometry of a typical cul-de-sac.

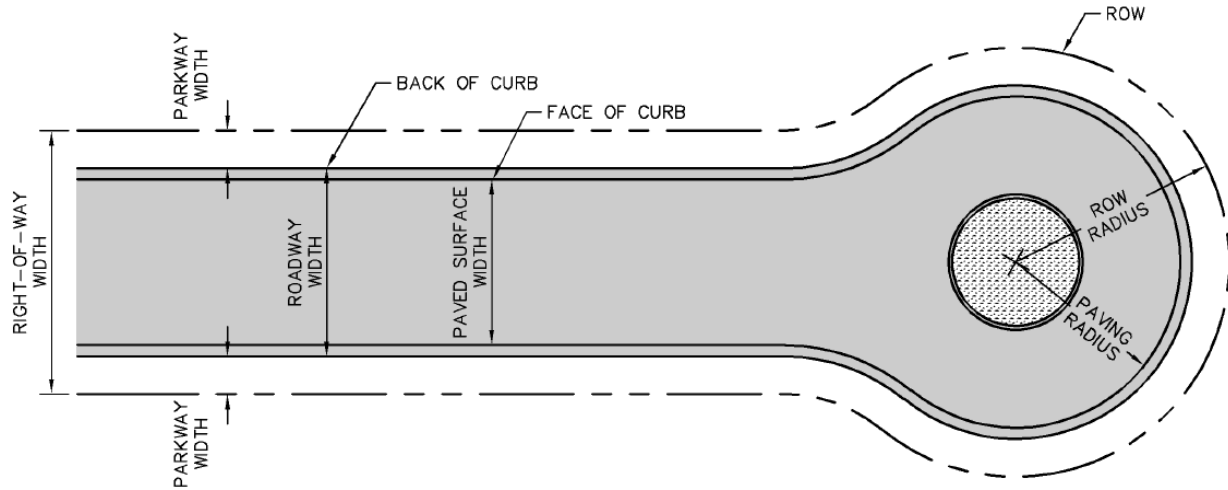

Figure 3-14. Cul-De-Sac Geometry

Table 3-15. Cul-De-Sac/Dead-End Geometric Design Standards

Design Standard	Dimension
Right-of-Way (minimum width, ft)	50
Parkway Width (each side of street, ft)	10.5
Sidewalk Width (each side of street, ft)	5
Paved Surface (F-F of Curb)	28
Roadway Width (B-B of Curb)	29
Traffic Lanes (No. and Width)	2 at 10' each
Horizontal Centerline Radius (normal cross section, ft)	150
Target Speed (mph)	20-25
Minimum Street Spacing (CL-CL, ft)	135
Minimum Tangent Between Curves (ft)	50
Tangent at Intersections (ROW-ROW, ft):	
a) <i>Local/Collector</i>	50
b) <i>Local/Local</i>	50
c) <i>Ltd Local/Ltd Local</i>	40
Vertical Clearance (from roadway surface, ft)	14
Intersection Safe Sight Distance (ft)	350
Maximum Intersection Deviation Angle Allowed – from 90° (degrees)	5
Mid-Block Horizontal Street Change/Departure Angle Shall Not Be Less Than (degrees):	60
Percent Gradient of Streets and Alleys	
a) <i>Minimum %</i>	0.7
b) <i>Maximum %</i>	10.0
Reverse Curve:	
Minimum Tangent Separation Distance (ft)	50
Minimum Cul-De-Sac Turn-Around Dimensions (ft):	
a) <u>S/F and 2/F Districts:</u>	
1. <i>ROW Radius</i>	50
2. <i>Paving Radius (F-F)</i>	40
b) <u>Other Zoned Districts:</u>	
3. <i>ROW Radius</i>	60
4. <i>Paving Radius (B-B)</i>	50
Maximum ADT Traffic Design Volume	2,000
Design Trip Length	Under 0.25 mile
LEGEND:	
F-F – Face to Face	
B-B – Back to Back	
ADT – Average Daily Traffic Volume	

Contents



CHAPTER 4 - BICYCLE FACILITIES	4-5
4.1 Introduction	4-5
4.2 Active Transportation Plan	4-5
4.3 Planning for a Range of Bikeway Users	4-5
4.3.1 Designing for Interested but Concerned and Experienced and Confident Bicyclists.....	4-5
4.3.2 Impact of Roadway Characteristics on Bicycle Facility Selection.....	4-7
4.4 Bicycle Network.....	4-11
4.5 Bikeway Design Guidelines	4-12
4.5.1 Typical Application	4-12
4.5.2 Shared-Use Paths/Sidepaths	4-12
4.5.2.1 Considerations.....	4-12
4.5.3 Separated Bicycle Lanes.....	4-13
4.5.3.1 Considerations.....	4-14
4.5.3.2 Elements of the Street	4-14
4.5.4 Signing and Marking for Separated Bicycle Lanes	4-15
4.5.5 Separated Bicycle Lane Design Parameters	4-17
4.5.5.1 Considerations.....	4-17
4.5.5.2 One-Way Separated Bicycle Lanes	4-18
4.5.5.3 Two-Way Separated Bicycle Lanes	4-18
4.5.6 Separated Bicycle Lane Design Examples	4-19
4.5.6.1 One-Way Separated Bicycle Lanes	4-19
4.5.6.2 Two-Way Separated Bicycle Lanes	4-20
4.5.7 Buffered Bicycle Lanes.....	4-21
4.5.7.1 Considerations.....	4-21
4.5.7.2 Guidance	4-22
4.5.8 Contra-Flow Bicycle Lane	4-22
4.5.8.1 Considerations.....	4-23
4.5.8.2 Guidance	4-23
4.5.9 Bicycle Lanes.....	4-24
4.5.9.1 Considerations.....	4-24
4.5.9.2 Guidance	4-25
4.5.9.3 Bicycle Lane Symbol and Signage Placement	4-25
4.5.9.4 At Intersections	4-25
4.5.9.5 Frequency of Bicycle Lane Symbol	4-26
4.5.10 Advisory Bicycle Lanes	4-27
4.5.10.1 Considerations.....	4-27
4.5.10.2 Guidance	4-27
4.5.11 Shared Lane Markings	4-29
4.5.11.1 Considerations.....	4-29
4.5.11.2 Guidance	4-29
4.5.12 Transitions Between Bicycle Facilities.....	4-30
4.5.12.1 Considerations.....	4-31
4.5.12.2 Guidance	4-31

- 4.5.13 Transition from One-Way Separated Bicycle Lane to Conventional Bicycle Lane on Same Street.....4-33
 - 4.5.13.1 Considerations..... 4-33
 - 4.5.13.2 Guidance 4-34
- 4.5.14 Transition from Two-Way Separated Bicycle Lane to One-Way Separated Bicycle Lane on Intersecting Street.....4-35
 - 4.5.14.1 Considerations..... 4-35
 - 4.5.14.2 Guidance 4-36
- 4.5.15 Transition between One-Way Separated Bicycle Lanes at an Intersection 4-37
 - 4.5.15.1 Considerations..... 4-37
 - 4.5.15.2 Guidance 4-38
- 4.6 Enhancements and Supporting Treatments for Bicycle Facilities..... 4-39
 - 4.6.1 Bicycle Boulevard Treatments.....4-39
 - 4.6.1.1 Considerations..... 4-39
 - 4.6.1.2 Guidance 4-40
 - 4.6.2 Roundabout Treatments.....4-40
 - 4.6.2.1 Considerations..... 4-40
 - 4.6.2.2 Guidance 4-40
 - 4.6.3 Crossing Treatments.....4-40
 - 4.6.3.1 Considerations..... 4-41
 - 4.6.3.2 Guidance 4-41
 - 4.6.4 Bicycle Signals, Detection, Actuation4-41
 - 4.6.4.1 Considerations..... 4-42
 - 4.6.4.2 Guidance 4-42
 - 4.6.5 Bicycle Boxes.....4-43
 - 4.6.5.1 Considerations..... 4-43
 - 4.6.5.2 Guidance 4-43
 - 4.6.6 Two-Stage Turn Queue Box.....4-45
 - 4.6.6.1 Considerations..... 4-46
 - 4.6.6.2 Guidance 4-46
 - 4.6.7 Mixing Zones.....4-47
 - 4.6.7.1 Considerations..... 4-48
 - 4.6.7.2 Guidance 4-48
 - 4.6.8 Through Bicycle Lane Approach4-49
 - 4.6.8.1 Considerations..... 4-49
 - 4.6.8.2 Guidance 4-49
 - 4.6.9 Conflict Area Marking.....4-50
 - 4.6.9.1 Considerations..... 4-51
 - 4.6.9.2 Guidance 4-51
 - 4.6.10 Mid-Block Shared-Use Path Crossings4-51
 - 4.6.10.1 Considerations..... 4-51
 - 4.6.10.2 Guidance 4-51
 - 4.6.11 Separated Bicycle Lanes at Intersections (Protected Intersections)4-53
 - 4.6.11.1 Considerations..... 4-53
 - 4.6.11.2 Guidance 4-54
 - 4.6.12 Separated Bicycle Lanes at Roundabouts.....4-55
 - 4.6.12.1 Considerations..... 4-55

- 4.6.12.2 Guidance 4-55
- 4.6.13 Separated Bicycle Lanes at Driveways4-56
 - 4.6.13.1 Considerations 4-57
 - 4.6.13.2 Guidance 4-57
- 4.6.14 Bridge Design4-57
 - 4.6.14.1 Considerations 4-58
 - 4.6.14.2 Guidance 4-58
- 4.7 Implementation of Bikeway Network..... 4-59
 - 4.7.1 Separated Bicycle Lane Maintenance4-60
 - 4.7.1.1 Considerations 4-60
 - 4.7.2 Bicycle Parking4-62
 - 4.7.2.1 Considerations 4-62
 - 4.7.2.2 Guidance 4-62
 - 4.7.3 On-Street Bicycle Parking4-63
 - 4.7.3.1 Considerations 4-63
 - 4.7.3.2 Guidance 4-63
 - 4.7.4 Off-Street Bicycle Parking4-64
 - 4.7.4.1 Considerations 4-65
 - 4.7.4.2 Guidance 4-65
- 4.8 References for Bicycle Facility Design..... 4-65

List of Figures

- Figure 4-1. Facility Selection for Interested but Concerned 4-6
- Figure 4-2. Facility Selection for Highly Confident Bicyclists..... 4-6
- Figure 4-3. Bicyclist Design User Profiles..... 4-11
- Figure 4-4. Typical Section Selection Process (MTP)..... 4-12
- Figure 4-5. Example Driveway Crossing Solution for a Shared-Use Path..... 4-13
- Figure 4-6. Example of a Cross Section with a Separated Bike Lane..... 4-14
- Figure 4-7. Vertical Separation Elements. From Left: Raised Island, Flexible Delineator Post, Rigid Bollards..... 4-17
- Figure 4-8. One-Way Separated Bike Lane Widths by Bicyclist Frequency 4-18
- Figure 4-9. Two-Way Separated Bike Lane Widths by Bicyclist Frequency 4-19
- Figure 4-10. Varying Levels of One-way Separated Bicycle Lane Separation 4-19
- Figure 4-11. Varying Levels of Two-Way Separated Bicycle Lane Separation 4-20
- Figure 4-12. Buffered Bicycle Lane Width Guidance 4-21
- Figure 4-13. Example Cross Section with Contra-flow Bicycle Lanes..... 4-23
- Figure 4-14. Different Bicycle Lane Locations. From Left: Bike Lane Adjacent to Parking, Bike Lane Adjacent to a Curb, Bike Lane with Door Zone Marking 4-24
- Figure 4-15. Advisory Bicycle Lane Design Guidance 4-28
- Figure 4-16. Design Guidance for Shared Lane Markings..... 4-30
- Figure 4-17. Preferred Design of a Separated Bike Lane Transition to a Shared Bike Lane.. 4-31
- Figure 4-18. Preferred Design of a Separated Bicycle Lane Transition to a Conventional Bicycle Lane..... 4-33
- Figure 4-19. Preferred Design of a Two-Way Separated Bicycle Lane Transition to a One-Way Separated Bicycle Lane on a Cross Street..... 4-35

Figure 4-20. Preferred Design of a One-Way Separated Bicycle Lane Transition to a One-Way Separated Bicycle Lane on a Cross Street..... 4-37

Figure 4-21. Bicycle Box with Lead-In Bicycle Lane, HAWK Beacon..... 4-41

Figure 4-22. Example Bicycle Signals 4-42

Figure 4-23. Example Bicycle Box..... 4-43

Figure 4-24. Two-Stage Turn Queue Box Design with Consideration of Truck Turning Movements 4-45

Figure 4-25. Preferred Mixing Zone Design..... 4-47

Figure 4-26. Preferred Design of a Through Bicycle Lane Approach..... 4-49

Figure 4-27. Dotted Line Extensions, Bicycle Lane Markings, Colored Conflict Area, Colored Dash, Elephant’s Feet 4-50

Figure 4-28. A Shared-Use Path Realignment to Achieve a 90-Degree Crossing 4-52

Figure 4-29. Preferred Protection Intersection Designs 4-53

Figure 4-30. Example Design of a Separated Bicycle Lane at a Roundabout..... 4-55

Figure 4-31. Example Design of a Separated Bicycle Lane at a Driveway 4-56

Figure 4-32. Bridges Accommodating Pedestrians and Bicyclists 4-57

Figure 4-33. Installation of a Separated Bicycle Facility 4-59

Figure 4-34. A Separated Bicycle Lane with Leaf Debris..... 4-60

Figure 4-35. Example Designs of On-Street Bicycle Parking..... 4-64

List of Tables

Table 4-1. Bicycle Facility Selection Criteria by Roadway Type 4-7

Table 4-2. Intersection Control Treatments for Bicycle Facilities by Roadway Type 4-9

Table 4-3. Bicycle Lane Object Setbacks 4-16

Table 4-4. Traffic Volume Thresholds for Bicycle Boulevard Treatments..... 4-39

Table 4-5. Shifting Taper Equation..... 4-47

CHAPTER 4 - BICYCLE FACILITIES

4.1 INTRODUCTION

This chapter provides design guidance to support safe, convenient, and accessible travel for bicyclists. Design topics include facility considerations and guidance, intersection design, supporting treatments, and bicycle network implementation.

4.2 ACTIVE TRANSPORTATION PLAN

In addition to the guidance provided on this chapter, [Active Transportation Plan \(ATP\)](#), which includes the City's bicycle master plan on bicycle facilities, should be used for designing and planning bicycle facilities.

4.3 PLANNING FOR A RANGE OF BIKEWAY USERS

4.3.1 Designing for Interested but Concerned and Experienced and Confident Bicyclists

Bicyclists' comfort levels decrease proportionally with increases in motor vehicle volumes and a widening differential between the speed of bicycles and the speed of adjacent traffic. As a result, both traffic volume and traffic speed are important considerations when choosing an appropriate bikeway type for a given location. In general, as both volume and speed increase, there is a greater need for separation of the bikeway from traffic to appeal to a wider cross-section of people, to design for all ages and abilities. Wider bikeways (i.e., more than the standard five feet) also help to mitigate the effects of volume and speed, albeit to a lesser extent than increasing facility separation with pavement marking buffers or physical barriers.

The Bicycle Facility Selection Charts (**Figure 4-1** and **Figure 4-2**) combine both speed and volume into a single chart to help identify an appropriate treatment for a given roadway assuming different design users. Research indicates that providing less protection/separation on roads with higher speeds and volumes will result in fewer people comfortable to bicycle on those roads. These charts are based on Level of Traffic Stress (LTS) Analysis, which was also conducted for the [Active Transportation Plan](#) to identify how comfortable corridors may be for certain bicycling user types. The LTS methodology should be referenced for understanding how different bicycle facilities affect user comfort and safety.

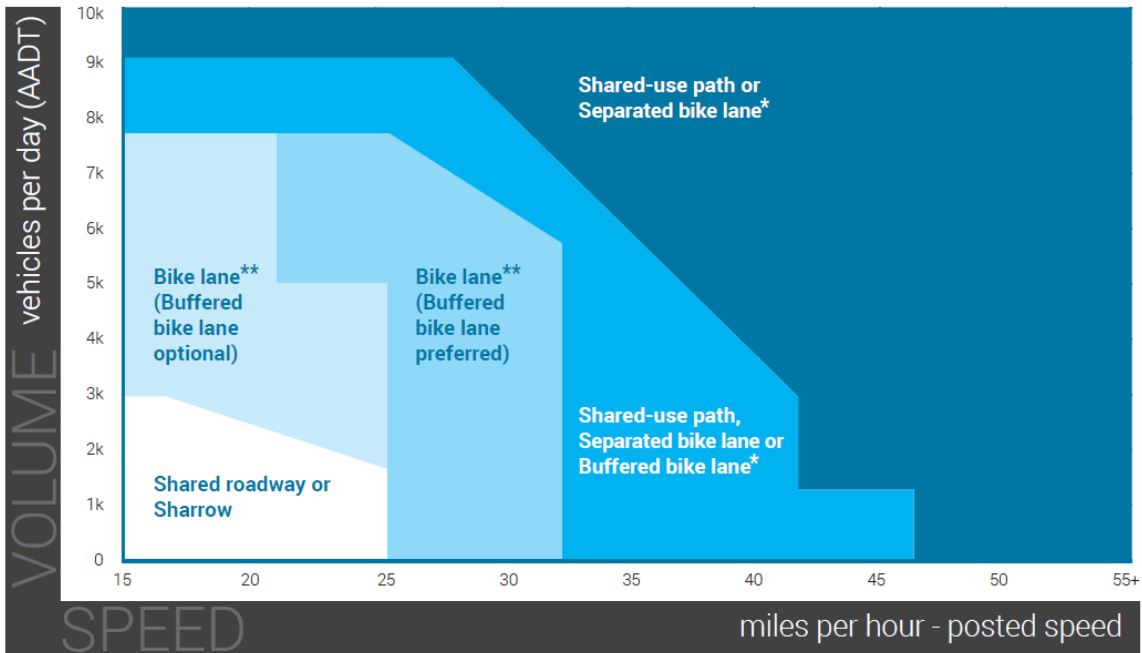

Figure 4-1. Facility Selection for Interested but Concerned

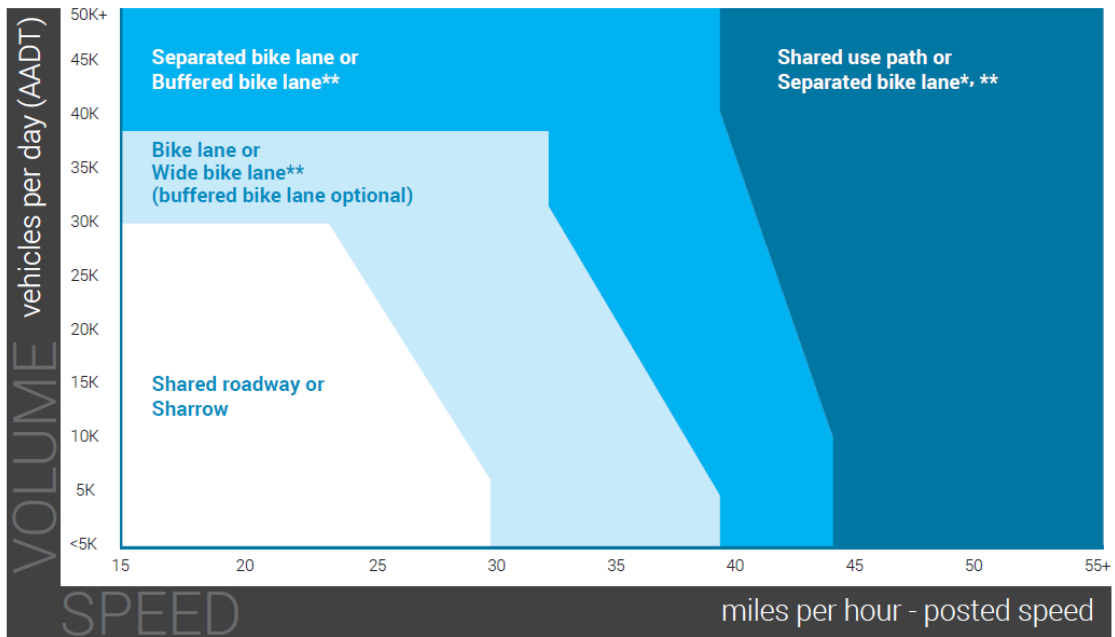

Figure 4-2. Facility Selection for Highly Confident Bicyclists

* Facility not likely to attract a broad spectrum of users given vehicle speed and/or volumes

** Can use shoulder bikeway as necessary

Charts are based on Level of Traffic Stress (Mekuria, Furth, Nixon, 2012) and empirical behavioral research on cyclist route choice (Lowry, Furth, Hadden-Loh, 2016).

4.3.2 Impact of Roadway Characteristics on Bicycle Facility Selection

Table 4-1 provides guidance on bicycle facility types that can be applied to corridors designated for improvement in the [Active Transportation Plan](#). Street type is an important factor in selecting the appropriate bicycle facility type for a given roadway, in addition to traffic volume and speed. The [Active Transportation Plan](#) identifies corridors and provides guidance for selecting facility types. See **Table 4-1** for information on appropriate bicycle facilities on different roadways, including the associated street types from the City’s [MTP](#).

Table 4-1. Bicycle Facility Selection Criteria by Roadway Type

Roadway Type/ Characteristics	Posted Speed	Lanes Per Direction	Presence of Parking	Traffic Volume (ADT)	Trails	Sidepaths, Separated Bike Lanes	Buffered Bike Lanes (8'+); Botts Dots	Conventional Bike Lanes (5'-6')	Signs and Shared Lane Markings (no roadways with no treatment)	Bicycle Boulevards with Traffic Calming
Independent Right of Way	n/a	n/a	n/a	n/a	P	n/a	n/a	n/a	n/a	n/a
Thoroughfares										
System Link	45	3	No	All Volumes	n/a	P	N	N	N	n/a
System Link	45	2	No	All Volumes	n/a	P	D	N	N	n/a
Commercial or Neighborhood Connector	35	3	No	All Volumes	n/a	P	D	N	N	n/a
Commercial or Neighborhood Connector	35	2	No	20,001+	n/a	P	D	N	N	n/a
Commercial or Neighborhood Connector	35	2	No	8,001 - 20,000	n/a	P	D	D	N	n/a
Commercial or Neighborhood Connector	35	2	No	<8,000	n/a	P	A	D	D	n/a
Commercial or Neighborhood Connector	35	1	No	1501+	n/a	P	A	A/D*	N	n/a
Commercial or Neighborhood Connector	35	1	No	751-1500	n/a	P	A	A	D	n/a
Commercial or Neighborhood Connector	35	1	No	<750	n/a	P	A	A	A	n/a
Commerce/Mixed Use or Activity Street	35	2	Yes	>8,000	n/a	P	D	D	N	n/a
Commerce/Mixed Use or Activity Street	35	2	Yes	<8,000	n/a	P	A	D	D	n/a
Commerce/Mixed Use or Activity Street	35	2	No	>8,000	n/a	P	A	D	D	n/a
Commerce/Mixed Use or Activity Street	35	2	No	<8,000	n/a	P	A	A	D	n/a

Table 4-1. Bicycle Facility Selection Criteria by Roadway Type

Roadway Type/ Characteristics	Posted Speed	Lanes Per Direction	Presence of Parking	Traffic Volume (ADT)	Trails	Sidepaths; Separated Bike Lanes	Buffered Bike Lanes (8'+); Botts Dots	Conventional Bike Lanes (5'-6')	Signs and Shared Lane Markings (no roadways with no treatment)	Bicycle Boulevards with Traffic Calming
Collectors or 2-Lane Commerce/Mixed Use or Activity Streets										
Residential/Industrial/Retail Collectors and Commerce/Mixed Use or Activity Streets	35	1	Yes	1501+	n/a	P	D	D	D	n/a
Residential/Industrial/Retail Collectors and Commerce/Mixed Use or Activity Streets	35	1	Yes	751-1500	n/a	P	A	D	D	A
Residential/Industrial/Retail Collectors and Commerce/Mixed Use or Activity Streets	35	1	Yes	0-750	n/a	P	A	A	D	P
Residential/Industrial/Retail Collectors and Commerce/Mixed Use or Activity Streets	35	1	No	1501+	n/a	P	D	D	D	n/a
Residential/Industrial/Retail Collectors and Commerce/Mixed Use or Activity Streets	35	1	No	751-1500	n/a	P	A	A	D	P
Residential/Industrial/Retail Collectors and Commerce/Mixed Use or Activity Streets	35	1	No	0-750	n/a	P	A	A	A	P
Local Streets										
Standard Local Streets	25-30	50' ROW	Yes	3,001-6,000	n/a	n/a	n/a	P	D	n/a
Standard Local Streets	25-30	50' ROW	Yes	1501-3000	n/a	n/a	n/a	P	A	A
Standard Local Streets	25-30	50' ROW	Yes	751-1500	n/a	n/a	n/a	P	P	P
Standard Local Streets	25-30	50' ROW	Yes	0-750	n/a	n/a	n/a	P	P	P
Limited Local Streets	25-30	40' ROW	No	0-1000	n/a	n/a	n/a	P	P	P

Notes:

n/a = not applicable; P = Preferred; A = Acceptable; D = Discouraged; N = Not Recommended. These equate to stress levels referenced in the Active Transportation Plan.

The recommendation for treatments are based on Level of Traffic Stress research and best practice. Some planning-level judgments were made where existing documentation was not available. Additional information that may impact bicycling conditions should be considered to refine the facility selection.

Default Target Speeds are derived from the Fort Worth Master Thoroughfare Plan (MTP). The number of lanes and presence of parking are drawn from MTP cross sections.

For Collectors, the MTP calls for 8-foot bike lanes adjacent to parking.

At speeds of 35 mph and above, using in-street separated bike lanes as a bicycle treatment depends on design and robustness of physical separation. Flexposts and Botts Dots are likely to be an acceptable treatment, rather than a preferred treatment.

The preferred traffic volume for a bicycle boulevard is 1,000 ADT or lower. 2,000 ADT is acceptable; 3,000 ADT is the maximum; Bicycle boulevards should generally not exceed two lanes.

Shared Lane Markings are not recommended on roadways with speeds above 35 mph.

*This cross-section is an acceptable treatment below 6,000 ADT and a discouraged treatment above 6,000 ADT.

Table 4-2 provides guidance on the appropriateness of different infrastructure and intersection control treatments used with bicycle facilities as seen in the [Active Transportation Plan](#). Several factors such as speed and the number of automobile travel lanes impact the effectiveness of these treatments.

Table 4-2. Intersection Control Treatments for Bicycle Facilities by Roadway Type

Characteristics of the roadway being crossed by the bicyclist			Presence of infrastructure/control at the intersection being crossed by the bicyclist									
Posted Speed	Lanes Per Direction to Cross	Total Lanes to Cross	Grade Separation	Protected Intersection			Traffic Signal with Dedicated Bicycle Signal Phase	Traffic Signal or HAWK (with concurrent bicycle and motorist movements)	Rapid Rectangular Flashing Beacon (RRFB)	Stop Sign (controlling the crossing traffic)	No Control (on the crossing traffic)	
				With Dedicated Bicycle Signal Phase	Without Dedicated Bicycle Signal Phase	Stop Control (on crossing traffic)						
Two-Way Streets												
40+	3	6	P	P	A	n/a	A	D	N	n/a	N	
40+	2	4	P	P	P	n/a	A	A	D	n/a	N	
35	3	6	P	P	A	n/a	P	D	N	n/a	N	
35	2	4	P	P	P	n/a	P	A	A	A (very rare)	D	
35	1 or 2	3	P	P	P	P	P	P	A	A	D	
35	1	2	P	P	P	P	P	P	A	P	A	
25-30	1	2	n/a	P	P	P	P	P	P	P	P	
One-Way Streets												
Crossing a one-way street requires watching for cross-traffic in one direction instead of two.												
40+	3		P	P	P	n/a	P	A	D	n/a	D	
40+	2		P	P	P	A	P	P	D	n/a	D	
35	3		P	P	P	n/a	P	P	A	n/a	A	
35	2		P	P	P	P	P	P	A	A (very rare)	A	
25-30	2		n/a	P	P	P	P	P	P	A (very rare)	P	

Notes:

n/a = not applicable; P = Preferred; A = Acceptable; D = Discouraged; N = Not Recommended. These equate to stress levels referenced in the Active Transportation Plan.

Protected intersection: The ratings in these tables are based on the Mineta Transportation Institute Low-Stress Bicycling and Network Connectivity methodology, which does not address protected intersections. The estimates in the table above are based on professional planning and engineering judgement. Protected intersections are judged as preferable compared to the default control (e.g. a protected intersection with a dedicated phase is preferred while a dedicated phase without a protected intersection is acceptable). Because the applicability of bicycle facilities at protected intersections is so dependent on the control, protected intersections are broken into three columns: dedicated bicycle signal phase, without dedicated bicycle signal phase, and stop controlled.

Median Islands: Median islands reduce the number of lanes a bicyclist must cross at a time. To evaluate the intersection applicability of a roadway with a median island, use the table above to look up the applicability of each leg of the crossing, using one-way streets and number of lanes to cross each leg.

Complex intersections: Multiple-leg intersections create additional problems for bicyclists and require special consideration for bicyclists.

Off-set intersections: Off-set intersections, made up of two T-intersections, should be evaluated based on the applicability at each of the T-intersections.

Turning movements: Turning movements and turn lanes increase bicyclist stress at intersections due to additional crossing distance and intersection complexity. Traffic signals with dedicated bicycle signal phases reduce bicyclist stress by separating movement timing between the modes. At intersections with significant turning movements and turn lanes, the stress estimate may be increased by 1 to 2 steps depending on number of turning vehicles and signal control based on the designer's professional judgement.

Additional design treatments: Additional design treatments are recommended to reduce turning vehicle speeds, communicate right of way, and provide designated space for bicyclists at intersections. These treatments should be installed when possible.

- Conflict markings
- Bike boxes
- 2-stage turn boxes
- Protected intersections
- Median Islands

Refer to Table 4-1 for information on appropriate bicycle facilities on different roadways. The selection of the appropriate design treatment at intersections depends on the facility along the roadway and intersection approach.

Roundabouts: While the confident bicyclist may be comfortable traversing a roundabout in a shared lane environment, many bicyclists will not feel comfortable navigating roundabouts with vehicular traffic, especially multilane roundabouts. For shared lane conditions, if a roundabout contains one circulating lane, then the appropriateness related to sharing the lane depends on the traffic volume (4,000 or less = preferred; 4,001 to 6,000 = acceptable; >6,000 = not recommended); if there is more than one circulating lane, sharing lanes is not recommended. Bike lanes are not to be located within the circulatory roadway of a roundabout. For comfort and safety reasons, roundabouts should be designed to facilitate bicycle travel outside of the circular roadway. The appropriateness of the intersection crossing will be determined by the number of lanes and speed of traffic being crossing. Refer to the table above.

4.4 BICYCLE NETWORK

As discussed in the [Active Transportation Plan](#), bicycle networks are interconnected bicycle facilities that allow people to safely and conveniently get where they want to go. Bicycle networks may be made of different types of bicycle facilities that provide bicyclists with varying degrees of separation from motor vehicle traffic, and may serve different types of users (i.e., “Interested but Concerned” as shown in **Figure 4-3**). The following section describes different types of bicycle facilities which may be found in Fort Worth’s current or planned bicycle network.

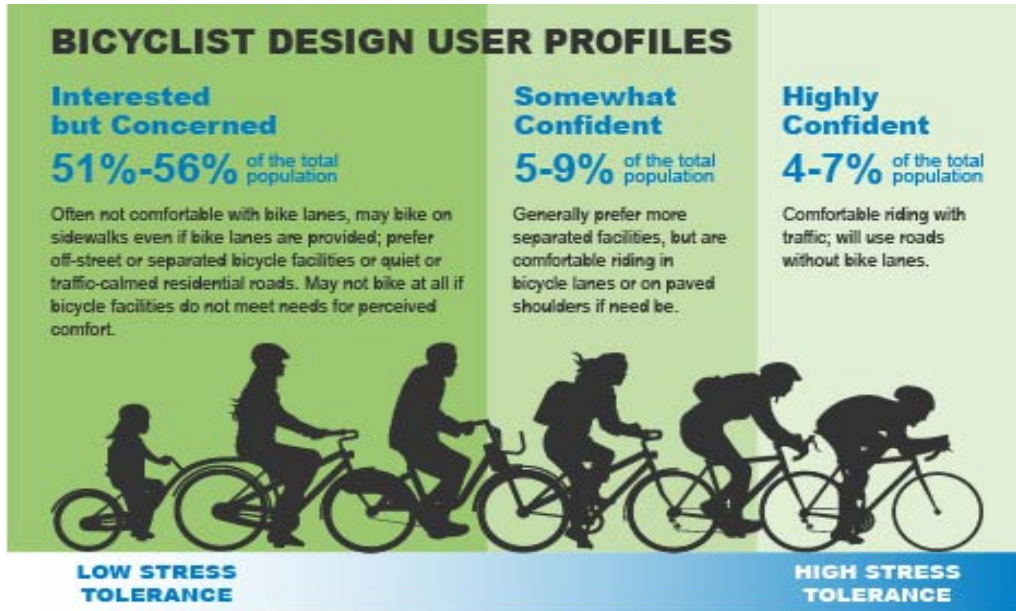

Figure 4-3. Bicyclist Design User Profiles

4.5 BIKEWAY DESIGN GUIDELINES

4.5.1 Typical Application

See **Figure 4-4** for additional considerations on bicycle facility selection as it relates to street types in the Fort Worth **MTP**, which illustrates a suite of cross-section typologies for thoroughfare street types.

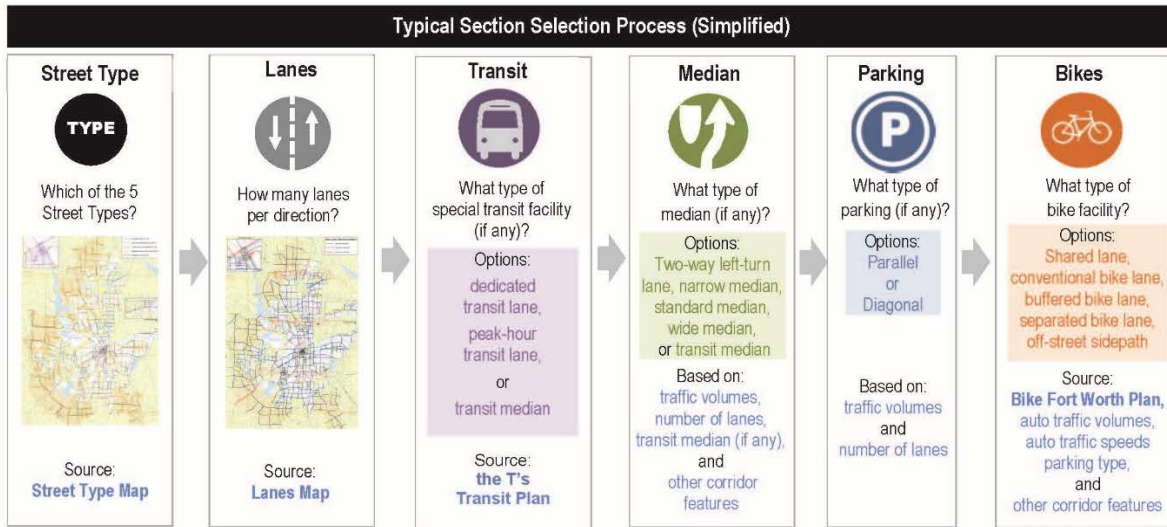

Figure 4-4. Typical Section Selection Process (MTP)

4.5.2 Shared-Use Paths/Sidepaths

A shared-use path is a one-way or a two-way facility physically separated from motor vehicle traffic and used by bicyclists, pedestrians, and other non-motorized users. Shared-use paths, also referred to as trails, are often located in an independent alignment, such as a greenbelt or abandoned railroad. However, they are also regularly constructed along roadways as a wide (10+ foot) sidewalk. Bicyclists and pedestrians will have increased interactions with motor vehicles at driveways and intersections on these “sidepaths,” which are two-way, multi-use paths adjacent to the roadway, serving both pedestrians and cyclists.

Shared-use paths and sidepaths are scored as LTS 1 (All ages and abilities) at all times, as they maximize separation from motor vehicle traffic and are designed with minimal conflicts. In the **MTP**, sidepaths are not used on Activity Streets and Commerce/Mixed-Use Streets, because mixing bicycle and pedestrian traffic in the active space between the curb and building front is not considered appropriate. For the three other Street Types, sidepaths are used in locations that are not on the Bicycle Priorities map – routes that are not considered major bicycle commuter routes. All cross-sections with sidepaths provide them on both sides of the roadway to facilitate bicycle mobility and connectivity.

4.5.2.1 Considerations

The standard shared-use path and sidepath is 10 feet wide, with a minimum buffer from the curb of 2.5 feet. Widths as narrow as 8 feet are acceptable for short distances under physical constraint. Warning signs should be considered at these locations.

In locations with higher volumes of users (more than 300 total in the peak hour, considering a pedestrian mode split of less than 30 percent), widths exceeding 10 feet are recommended. A minimum of 11 feet is required for users to pass with a user traveling in the other direction. It may be beneficial to separate bicyclists from pedestrians by constructing parallel paths for each mode.

Driveway volumes should be assessed on a case-by-case basis to design for minimizing conflicts between bicycle facility users and motor vehicles. Consider using color and other design details to send a message to motorists entering driveways that they must be alert to trail users from both directions. **Figure 4-5** shows a possible driveway crossing solution for a shared-use path. The highest risk conflict is a left turning vehicle that cannot see a bicyclist about to enter from behind their search pattern. The wider the road, the higher the crash potential.

Paths must be designed according to state and national standards. This includes establishing a design speed (typically 18 mph) and designing path geometry accordingly. Consult the [AASHTO Guide for the Development of Bicycle Facilities](#) for guidance on geometry, clearances, traffic control, railings, drainage, and pavement design. Shared-use paths must also conform to [Public Rights-of-way Accessibility Guidelines \(PROWAG\)](#) if in a public right-of-way or Advance Notice of Proposed Rulemaking (AN-PRM) on Accessibility Guideline for shared-use paths if in a private right-of-way.

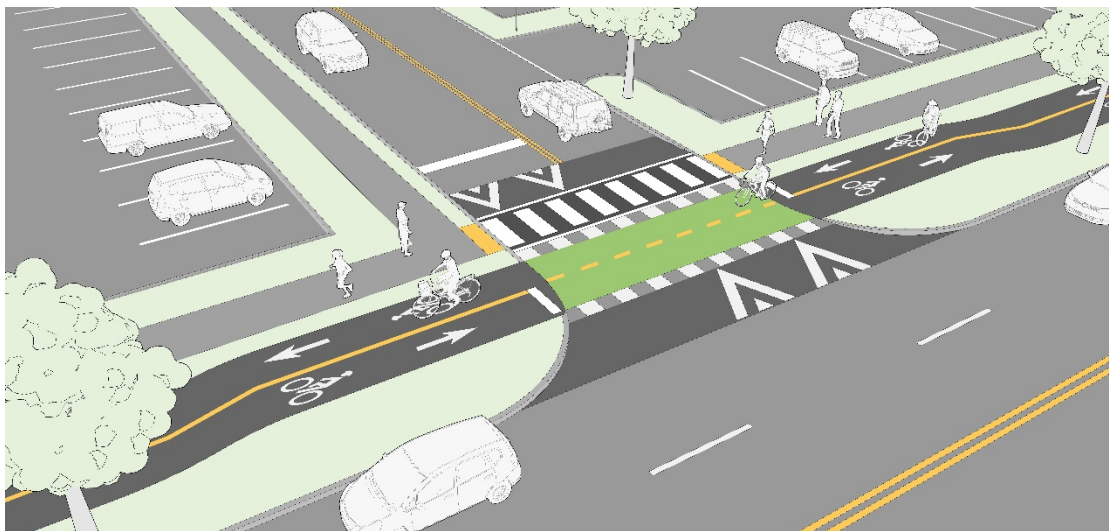

Figure 4-5. Example Driveway Crossing Solution for a Shared-Use Path

4.5.3 Separated Bicycle Lanes

Separated Bicycle Lanes (also known as protected bicycle lanes or cycle tracks) are an exclusive bikeway facility type that combines the user experience of a sidepath with the on-street infrastructure of a conventional bicycle lane. They are physically separated from motor vehicle traffic and distinct from the sidewalk but may be at sidewalk level. Separated bicycle lanes are more attractive to a wider range of bicyclists than striped bikeways on higher volume and higher speed roads. They eliminate the risk of a bicyclist being hit by an opening car door and prevent motor vehicles from driving, stopping, or waiting in the bikeway. They also provide greater comfort to pedestrians by separating them from bicyclists operating at higher speeds, and further separate pedestrians from motor vehicles. Regarding LTS, separated bike lanes are scored according to

the type of separation mechanism, the number of adjacent travel lanes and the posted speed limit. **Figure 4-6** shows an example cross section with a separated bike lane.

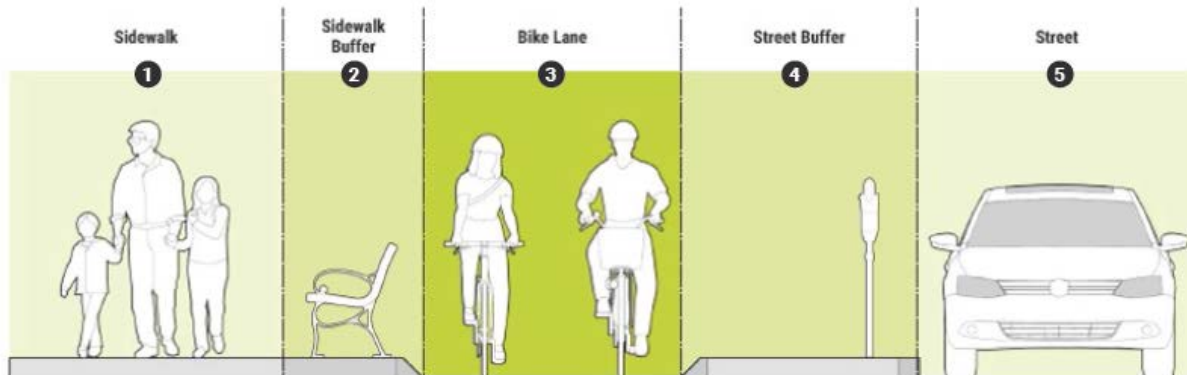

Figure 4-6. Example of a Cross Section with a Separated Bike Lane

4.5.3.1 Considerations

- Separated bicycle lanes can provide different levels of separation:
 - Separated bicycle lanes with flexible delineator posts (“flexposts”) alone offer the least separation from traffic and are appropriate as an interim solution, depending on the land use context. Flexible delineator posts can be visually obtrusive in single-family neighborhoods.
 - Separated bicycle lanes that are raised with a wider buffer from traffic provide the greatest level of separation from traffic, but often require road reconstruction.
 - Separated bicycle lanes that are protected from traffic by a row of on-street parking offer a high degree of separation.

In constrained environments, reductions should be made to the street and vehicle space before narrowing sidewalks and other spaces allocated to pedestrians. This reduction can include decreasing the number of travel lanes, narrowing existing travel and turn lanes, or adjusting on-street parking.

4.5.3.2 Elements of the Street

- The sidewalk width is determined by street type in the [MTP](#) and the anticipated peak hour pedestrian volume. It should be 5 feet wide if detached from the curb or 6-7 feet wide if attached to the curb in residential settings and 8-12+ feet wide in downtown or commercial areas. The sidewalk should not be narrowed beyond the minimum standard based on the street type.
- The sidewalk buffer (nature strip, planter row) is required. For ADA compliance, buffers are the most supportive and least complex way to address accommodation. The sidewalk buffer zone separates the bicycle lane from the sidewalk, communicating that each are distinct spaces. By separating people walking and bicycling, encroachment into these spaces is minimized and the safety and comfort is enhanced for both users.
- Separated bicycle lanes generally attract a wider spectrum of bicyclists, some of whom operate at slower speeds, such as children or seniors. Because the elements used to separate the bicycle lane from the adjacent motor vehicle lane include some vertical component, bicyclists usually do not have the option to pass each other by moving out of the separated

bicycle lane. The bicycle lane zone should therefore be sufficiently wide to enable passing maneuvers between bicyclists.

- The bicycle lane width should be at least 6 feet for one-way bicycle lanes with volumes less than 150 per peak hour.
 - The bicycle lane width should be at least 11 feet for two-way bikeways with volumes less than 150 per peak hour to ensure bicyclists can safely pass each other.
 - In constrained conditions where recommended width cannot be achieved, two-way bikeways should be a minimum of 8 feet.
 - A minimum shy distance of 1 foot should be provided between any vertical objects in the sidewalk or street buffer and the bicycle lane.
- The street buffer is required and should provide separation from the street with vertical objects or a median. The street buffer increases user comfort while helping motor vehicles achieve target speeds and follow correct behaviors. The street buffer can consist of parked cars, vertical delineators, raised medians, landscaped medians, and a variety of other elements. The buffer should be at least 2 feet wide at midblock locations and should be between 6 feet and 20 feet at intersections, to provide maximum safety benefits. Intersections must be designed to consider potential conflicts with motor vehicle traffic. Where the buffer is reduced below 6 feet, consider a raised bicycle crossing or signal phase separation.
 - Facilities that must be accessed from the street (e.g., mailboxes, trash bins) should be placed in the street buffer (see Implementation of Bikeway Network).
 - Travel lanes and parking (7.5-8 feet) can be narrowed to the minimum width of 10 feet in constrained corridors.
 - Driveway volumes should be assessed on a case-by-case basis to design for minimized conflicts between bicycle facility users and motor vehicles. Driveways with low volumes of motor vehicle traffic have fewer potential conflicts and their crossings can be marked with a standard separated bike lane crossing. Driveways that serve higher than 20 crossings per day should incorporate design treatments such as a motorist yield zone or raised crosswalk.

4.5.4 Signing and Marking for Separated Bicycle Lanes

- Sign placement must meet minimum setback distance requirements (**Table 4-3**). Depending on sign type and messaging, they may be placed within the street buffer if sufficient width is provided. Parking signs should be placed within the street buffer when sufficient width is provided.
- Surfacing:
 - Asphalt pavement is generally recommended for the bicycle lane zone as it is the smoothest surface and does not require pavement joints.
 - If concrete surfacing is used, joints should be sawcut to maintain a smooth surface. A contrasting material is preferred when the bicycle lane is at sidewalk level to indicate a different use.
 - Colorized pavement or other materials should be considered at driveways.
 - In retrofit situations, remove longitudinal seams within the bicycle lane zone by patching the surface material or grinding smooth the existing seam and using crack sealant.

- If existing concrete panels have shifted, joints should be chamfered or otherwise treated to ensure a smooth transition.
- Existing utility lids should be adjusted to finished grade and examined on a case-by-case basis to determine if interventions are needed to reduce the risk of slipping.
- Typical signage may include:
 - WATCH FOR TURNING VEHICLES to warn counterflow bicyclists approaching intersections.
 - BIKE MAY USE FULL LANE in a transition to a shared lane.
 - It may be desirable to post BIKES MAY USE FULL LANE signs and advise faster bicyclists that they should operate in the roadway if their higher operating speed cannot be safely accommodated on the bicycle facility.

Table 4-3. Bicycle Lane Object Setbacks

Setback	Object height < 36"	Object height > 36"
Preferred	12"	18"
Minimum	6"	12"

4.5.5 Separated Bicycle Lane Design Parameters

Separated bicycle lanes may be located at sidewalk level, street level, or at an elevation intermediate to the sidewalk and street. Separated bicycle lanes are physically separated from motor vehicles and pedestrians by vertical and horizontal elements. Examples of vertical separation elements are shown in **Figure 4-7**.

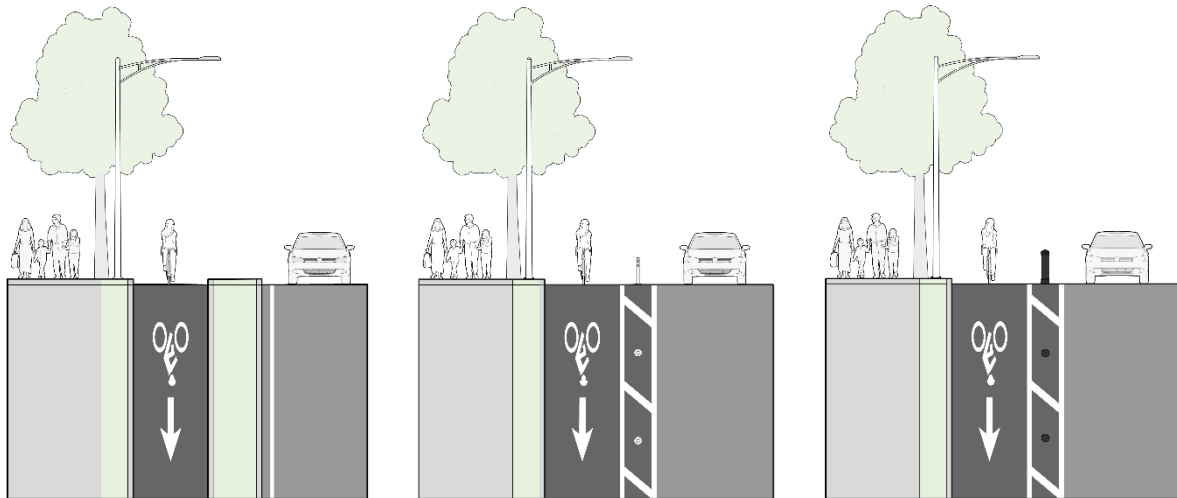

Figure 4-7. Vertical Separation Elements. From Left: Raised Island, Flexible Delineator Post, Rigid Bollards

4.5.5.1 Considerations

Sidewalk-level bicycle lanes:

- May encourage pedestrian and bicyclist encroachment unless discouraged with a continuous sidewalk buffer.
- Requires no transition for raised bicycle crossings at driveways, alleys or streets.
- The intended design of these lanes is to use asphalt, a contrasting material, and to visually separate them from the sidewalk with a one-foot-wide buffer providing additional contrast (stamped concrete, more frequent grooving, paver blocks, etc.).
- May provide level landing areas for parking, loading or bus stops along the street buffer.
- May reduce maintenance needs by prohibiting debris build up from roadway runoff.

Intermediate-level bicycle lanes:

- Preserve separation between bicyclists and pedestrians where sidewalk buffers are eliminated.
- Ensures a detectable edge is provided for people with vision disabilities.
- May reduce maintenance needs by prohibiting debris build up from roadway runoff.

- May require careful consideration of drainage design and, in some cases, may require catch basins to manage bicycle lane runoff.

Street-level bicycle lanes:

- Preserve separation between bicyclists and pedestrians where sidewalk buffers are eliminated.
- Ensures a detectable edge is provided for people with vision disabilities.
- May increase street sweeping to remove debris from roadway runoff unless street buffer is raised.
- May require careful consideration of drainage design and, in some cases, may require catch basins to manage bicycle lane runoff.

4.5.5.2 *One-Way Separated Bicycle Lanes*

The recommended and minimum widths of a one-way separated bicycle lane is shown in **Figure 4-8**.

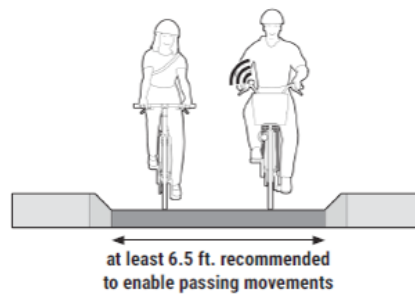

Same Direction Bicyclists/ Peak Hour	Bike Lane Width (ft.)	
	Rec.	Min.
<160	6.5	5.0
160-750	8.0	6.5
>750	10.0	8.0

Figure 4-8. One-Way Separated Bike Lane Widths by Bicyclist Frequency

A constrained bicycle lane width of 4 feet (one-way only) may be used for short distances to navigate around transit stops, accessible parking spaces, or other obstacles. There is no maximum length for a constrained facility, but it should only be used to accommodate a physical constraint.

4.5.5.3 *Two-Way Separated Bicycle Lanes*

The recommended and minimum widths of a two-way separated bicycle lane is shown in **Figure 4-9**.

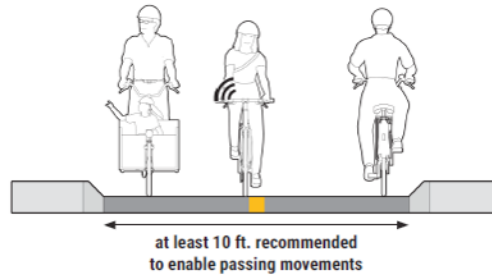

Bidirectional Bicyclists/ Peak Hour	Bike Lane Width (ft.)	
	Rec.	Min.
<150	10.0	8.0
150-400	11.0	10.0
>400	14.0	11.0

Figure 4-9. Two-Way Separated Bike Lane Widths by Bicyclist Frequency

4.5.6 Separated Bicycle Lane Design Examples

Separated bicycle lanes may operate as one-way or two-way facilities. Determining the appropriate configuration for a separated bicycle lane requires consideration of street operations, transitions to other bicycle facilities, and connectivity within the larger bicycle network.

4.5.6.1 One-Way Separated Bicycle Lanes

One-way separated bicycle lanes in the direction of motorized travel provide intuitive and simplified transitions to existing bicycle lanes and shared travel lanes. Varying levels are shown in **Figure 4-10**.

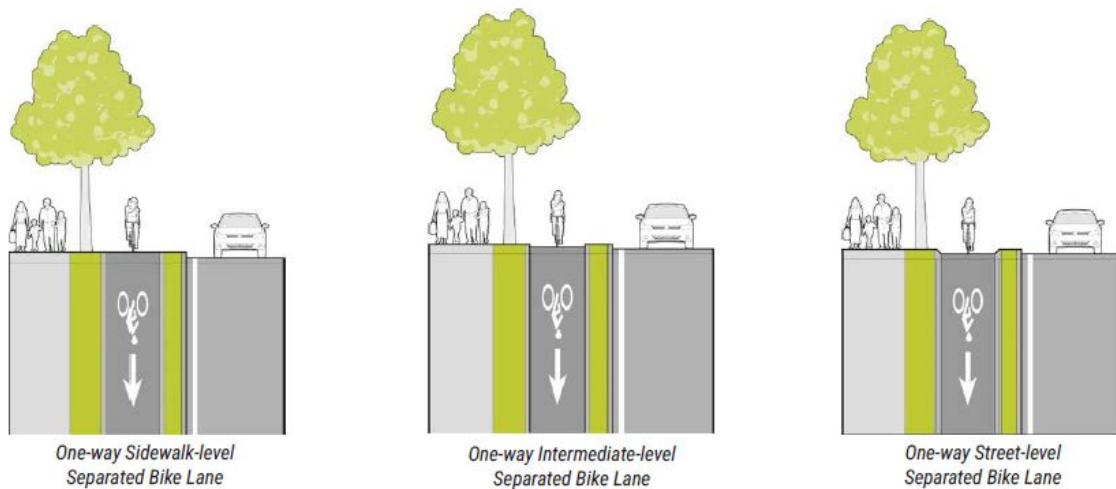

Figure 4-10. Varying Levels of One-way Separated Bicycle Lane Separation

4.5.6.2 *Two-Way Separated Bicycle Lanes*

Two-way separated bicycle lanes will require special attention to transition the contra-flow bicyclist into existing bicycle lanes and shared travel lanes. Varying levels are shown in **Figure 4-11**.

Depending on context, motorists may not expect bicyclists to approach crossings from both directions. For this reason, two-way separated bicycle lanes may require detailed treatments at alley, driveway, and street crossings to enhance the safety of these crossings.

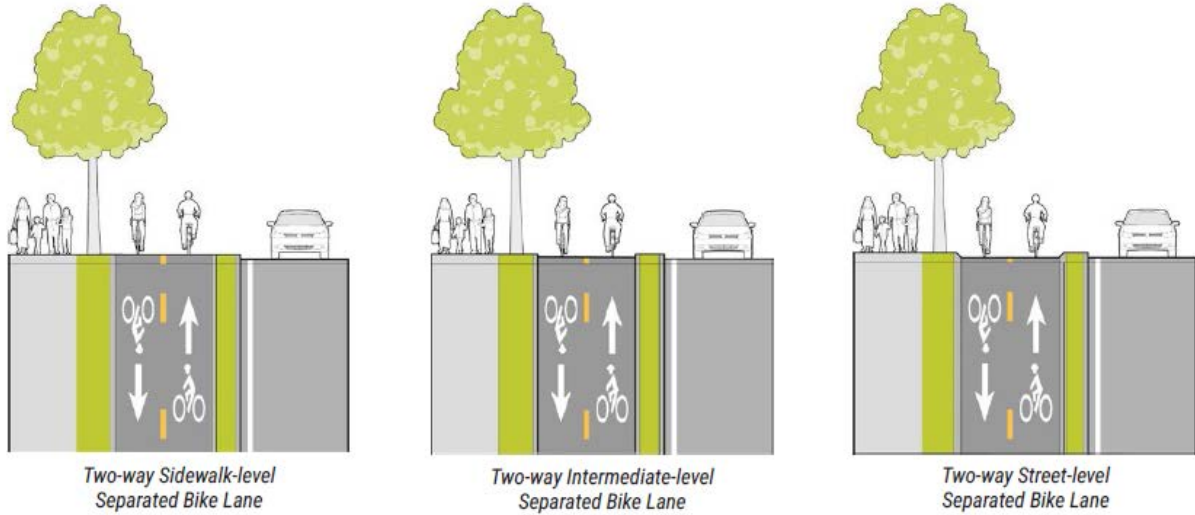
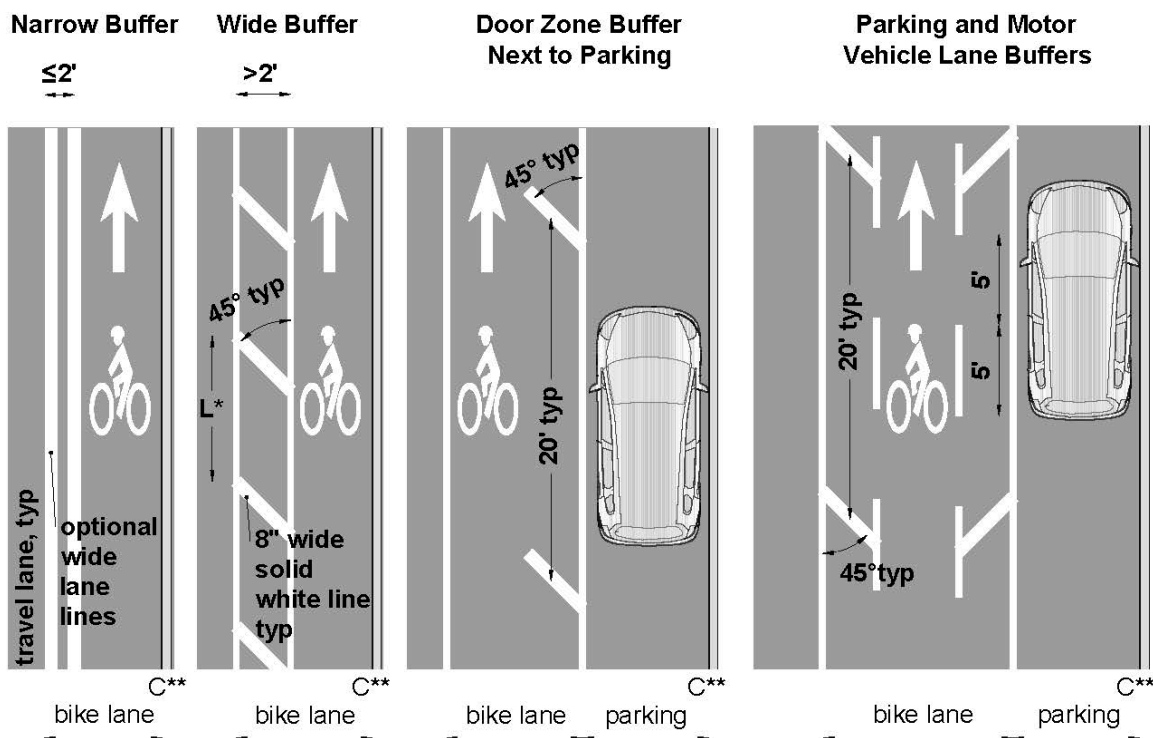

Figure 4-11. Varying Levels of Two-Way Separated Bicycle Lane Separation

4.5.7 Buffered Bicycle Lanes

Buffered bicycle lanes are created by pavement markings or otherwise creating a flush buffer zone between a bicycle lane and the adjacent travel lane. While buffers are typically used between bicycle lanes and motor vehicle travel lanes to increase bicyclists' comfort, they can also be provided between bicycle lanes and parking lanes in locations with high parking turnover to discourage bicyclists from riding too close to parked vehicles. Buffered bike lanes are typically installed by reallocating existing street space, and it is preferable to a conventional bicycle lane when used as a contra-flow bicycle lane on one-way streets. Buffered bike lane LTS scores depend on amount of separation, the number of adjacent travel lanes, and the posted speed limit. **Figure 4-12** provides guidance on buffered bicycle lane widths.



L*: 20' (min); L= posted speed limit (max)
 C**: curb; if gutter is present, bike lane measured to edge of gutter

Figure 4-12. Buffered Bicycle Lane Width Guidance

4.5.7.1 Considerations

- Can be used on one-way or two-way streets.
- Consider placing buffer next to parking lane where there is moderate to high turnover commercial or metered parking.
- Consider placing buffer next to travel lane where speeds are 30 mph or greater or when traffic volume exceeds 6,000 vehicles per day.

- Buffered bicycle lanes allow bicyclists to pass slower moving bicyclists.
- Research has documented buffered bicycle lanes increase the perception of safety.

4.5.7.2 Guidance

- The minimum width of a buffered bicycle lane adjacent to parking or a curb is 5 feet exclusive of gutter (if present); a desirable width is 6 feet.
- Adjacent to parallel parking, use a 3-foot buffer.
- Adjacent to diagonal parking, use a 2-foot buffer.
- Where there is 7 feet of roadway width available for a bicycle lane, a buffered bicycle lane should be installed instead of a conventional bicycle lane.
- Typical buffer widths are 3 to 5 feet, but even a 12-18" buffer is helpful.
- The preferred minimum buffer width is 18 inches. There is no maximum width. Diagonal cross hatching should be used for buffers less than 3 feet in width. Chevron cross-hatching should be used for buffers greater than 3 feet in width.
- Buffers are to be broken where curbside parking is present to allow cars to cross the bicycle lane.
- Add total minimum width of buffer, include use of reflectors on outside stripe to improve longevity

4.5.8 Contra-Flow Bicycle Lane

One-way streets and irregular street grids can make bicycling to specific destinations within short distances difficult. Contra-flow bicycle lanes can help to solve this problem by enabling only bicyclists to operate in two directions on one-way streets. Contra-flow lanes are useful to reduce distances bicyclists must travel and can make bicycling safer by creating facilities that help other roadway users understand where to expect bicyclists. **Figure 4-13** shows an example cross section with contra-flow bicycle lanes.

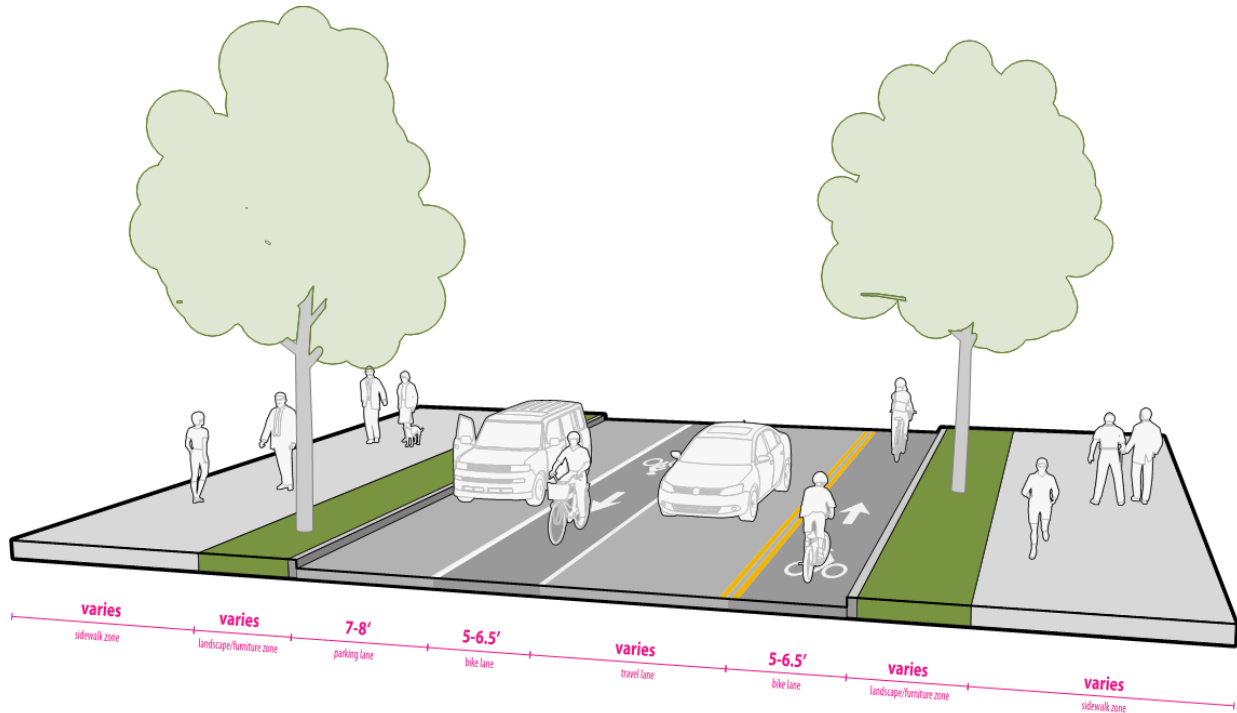

Figure 4-13. Example Cross Section with Contra-flow Bicycle Lanes

4.5.8.1 Considerations

- Contra-flow lanes follow the same design parameters as conventional bicycle lanes. However, the left side marking is a double yellow line. The line should be dashed if parking is provided on both sides of the street. Contra-flow lanes may also be separated by a buffer or vertical separation such as a curb.
- Contra-flow lanes must be placed to the motorist's left. A bicycle lane or other marked bicycle facility should be provided for bicyclists traveling in the same direction as motor vehicle traffic on the street to discourage wrong-way riding in the contra-flow lane.
- Parking is discouraged against the contra-flow lane as drivers' view of oncoming bicyclists would be blocked by other vehicles. If parking is provided, a buffer is recommended to increase the visibility of bicyclists. On-street parking should be restricted at corners.
- Contra-flow lanes are less desirable on streets with frequent and/or high-volume driveways or alley entrances on the side with the proposed contraflow lane. Drivers may neglect to look for opposing direction bicyclists on a one-way street.

4.5.8.2 Guidance

- Contra-flow bicycle lanes are used on one-way streets that provide more convenient or direct connections for bicyclists where other alternative routes are less desirable or inconvenient.
- Contra-flow lanes should be used where there is a clear and observed need for the connection as evidenced by wrong-way riding bicyclists or bicyclists riding on sidewalks in the opposing direction.

- Contra-flow lanes are often short, connecting segments. They are not typically used along extended corridors.
- Contra-flow lanes may only be established where there is adequate roadway width for an exclusive lane.
- Care should be taken in the design of contra-flow lane termini. Bicyclists should be directed to the proper location on the receiving roadway.

4.5.9 Bicycle Lanes

Bicycle lanes provide an exclusive space for bicyclists in the roadway. Bicycle lanes are established by pavement markings and symbols on the roadway surface. Bicycle lanes are for one-way travel and are normally provided in both directions on two-way streets and/or on one side of a one-way street. Bicyclists are not required to remain in a bicycle lane when traveling on a street and may leave the bicycle lane as necessary to make turns, pass other bicyclists, or to properly position themselves for other necessary movements. Bicycle lanes may only be used temporarily by vehicles accessing parking spaces and entering and exiting driveways and alleys and making right hand turns when no right turn storage lane exists. Stopping, standing, and parking in bicycle lanes is prohibited. Due to decreased separation from motor vehicle traffic, bicycle lanes may have a higher LTS; however the LTS score also takes into account travel lanes and post speed limit. **Figure 4-14** shows possible bicycle lane locations.

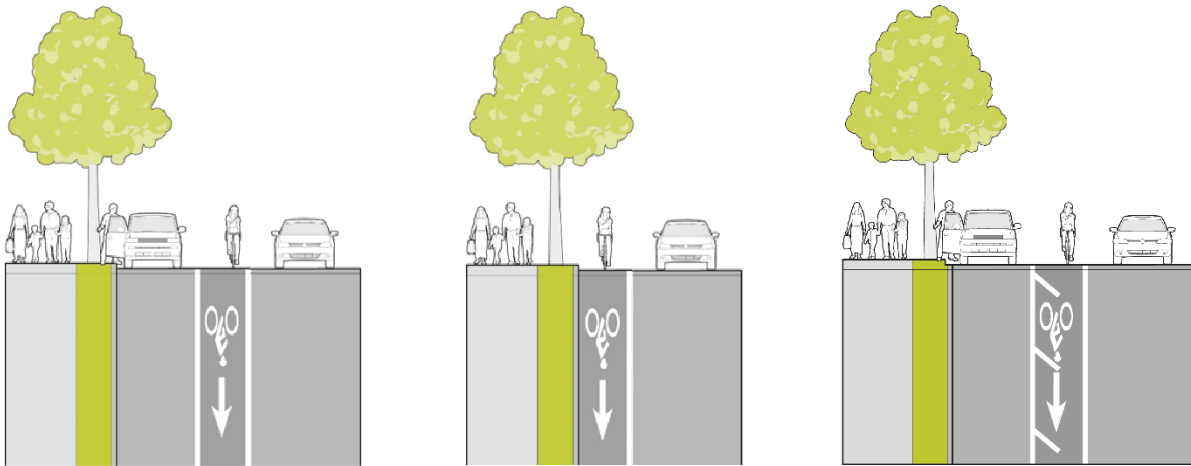

Figure 4-14. Different Bicycle Lane Locations. From Left: Bike Lane Adjacent to Parking, Bike Lane Adjacent to a Curb, Bike Lane with Door Zone Marking

4.5.9.1 Considerations

- Typically installed by reallocating existing street space.
- Can be used on one-way or two-way streets.
- Contra-flow bicycle lanes may be used to allow two-way bicycle travel on streets designated for one-way motor vehicle travel to improve bicycle network connectivity.

- Stopping, standing and parking in bicycle lanes may be an issue in areas of high parking demand and deliveries, especially in commercial areas and schools.
- On-street parking should be restricted at corners to ensure bicyclists and cross-street traffic have adequate visibility to each other.
- Wider bicycle lanes or buffered bicycle lanes are preferable at locations with high parking turnover.
- Bicycle lanes can be placed on the left side of one-way streets and some median-divided streets, resulting in fewer conflicts between bicyclists and motor vehicles, particularly on streets with heavy right-turn volumes, on-street parking, and/or frequent bus service.
- Signage and frequency of warning signage should be evaluated based on anticipated crossing, merging, or turning traffic.

4.5.9.2 *Guidance*

- The minimum width of a bicycle lane adjacent to a curb is 5 feet exclusive of a gutter (4 feet in highly constrained locations); a desirable width is 6 feet.
- The minimum width of a bicycle lane adjacent to 8-foot parking is 5 feet; a desirable width is 6 feet.
- Optional parking T's or hatch marks can highlight the door zone on constrained corridors with high parking turnover to guide bicyclists away from motor vehicle doors.
- Mill edge pavement to achieve a seamless transition to the gutter pan
- Under constrained conditions consider extending the gutter pan to capture the full bicycle lane width. This practice not only captures needed operating width, it offers the possibility of contrasting colors to create a visually tighter roadway.
- In some cases, pavement overlays to the curb face still works for drainage purposes and eliminates the shy distance from the gutter pan.
- When hilly roads are an issue, for grades above 3% consider a climbing lane, 6+ feet on the uphill side, with no bike lanes on the downhill side (bicyclists should be invited to use the full travel lane).

4.5.9.3 *Bicycle Lane Symbol and Signage Placement*

The bicycle lane symbol with arrow should be centered within the bicycle lane. When adjacent to parking, the outside edge of the bicycle lane symbol may be offset to be closer to the outside bicycle lane line or curb to encourage bicyclists to ride outside of the door zone.

Bicycle lane symbols will be placed at the far side of an uncontrolled intersection, at both sides of arterial intersection with traffic control, and at mid-block locations where block faces are more than 250 feet. For roadways with few intersecting streets, bicycle lane symbols should be placed every 600 feet.

4.5.9.4 *At Intersections*

- **Near side**

- Bicycle lane symbols will be placed on the near side of an intersection when there is a bus zone on the far side of an intersection. The tip of the bicycle lane arrow will be placed at the end of the solid lines, or 20 feet from the closest edge of the marked crosswalk or tangent point of the curb radius if no crosswalk is present.
- Where there are parking restrictions or a bus zone, the tip of the bicycle lane arrow will be placed at the end of the solid lines.
- At a location with no marked crosswalk, the tip of the bicycle lane arrow will be placed 20 feet ahead of the stop bar or, if none exists, at the tangent point of the curb radius of the intersection.
- **Far side**
 - On a typical intersection with no parking restrictions or bus zone, the tip of the bicycle lane arrow will be placed 25 feet from the tangent point of the curb radius.
 - Where there is a parking restriction (e.g., bus zone), the tip of the bicycle lane arrow will be placed 25 feet beyond the point where the solid line begins (i.e., parking restriction ends).

4.5.9.5 *Frequency of Bicycle Lane Symbol*

- The frequency of placement of a bicycle lane symbol will depend on several factors:
 - Visibility to motorists and bicyclists (i.e. markings should be placed to account for changes in topography or not be blocked by overhanging vegetation or signs when looked at from a distance).
 - Generally the markings should be located in accordance with the proposed guidelines (far side of intersections; then mid-block if block faces are more than 250 feet long).
 - Generally the markings should not be located directly across from each other when located mid-block. It is recommended that they be separated by a minimum of 20 feet. Use judgment to adjust if the street becomes too crowded with symbols.

4.5.10 Advisory Bicycle Lanes

Advisory bicycle lanes (ABLs) are used to create narrow streets where bicyclists are provided priority movement and motorists are compelled to yield to bicyclists as well as drivers approaching in the opposing direction. ABLs use dotted lane lines, allowing motorists to enter them to yield, and are designed using dimensions based on conventional bicycle lanes. ABLs are reserved for use on low-volume, low-speed streets.

4.5.10.1 Considerations

- Treatment requires FHWA permission to experiment.
- For use on streets too narrow for bicycle lanes and normal-width travel lanes.
- Provide two separate minimum-width bicycle lanes, on either side of a single shared (un-laned) two-way “yielding” motorist travel space.
- Motorists must yield to on-coming motor vehicles by pulling into the bicycle lane.
- To reduce motorist speeds, and to encourage yielding, the unmarked space between the two advisory bicycle lanes should be no wider than 18 feet.
- This treatment should only be used on streets with greater than 60% continuous daytime parking occupancy.
- Where parking occupancy is continuously less than 50%, it is preferable to consolidate the advisory bicycle lane to one side of the street or remove it.
- A Two-Way Traffic warning sign (W6-3) may increase motorists understanding of the intended two-way operation of the street.

4.5.10.2 Guidance

- The minimum width of the un-laned motorist space should be 12 feet between the bicycle lanes. The maximum width should be no more than 18 feet.
- The minimum width of an advisory bicycle lane adjacent to parking is 5 feet; a desirable width is 6 feet.
- The minimum width of an advisory bicycle lane adjacent to a curb is 4 feet exclusive of a gutter; a desirable width is 6 feet.

Advisory bikeways may be considered on any road with one or more of the following characteristics:

- Traffic lanes: 2 lanes or less.
- Posted speed limit: 25 mph or less.
- Traffic: 6,000 vehicles per day or less or 300 vehicles or less during the peak hour
- On-street parking turnover: infrequent.
- Street is not a designated truck or moderate to high volume bus route.

- Low volume Main Street conditions where delivery vehicles use the center of the street to make deliveries, and where motorists need space to pass the delivery vehicle.

Figure 4-15 shows the general layout of an advisory bike lane.

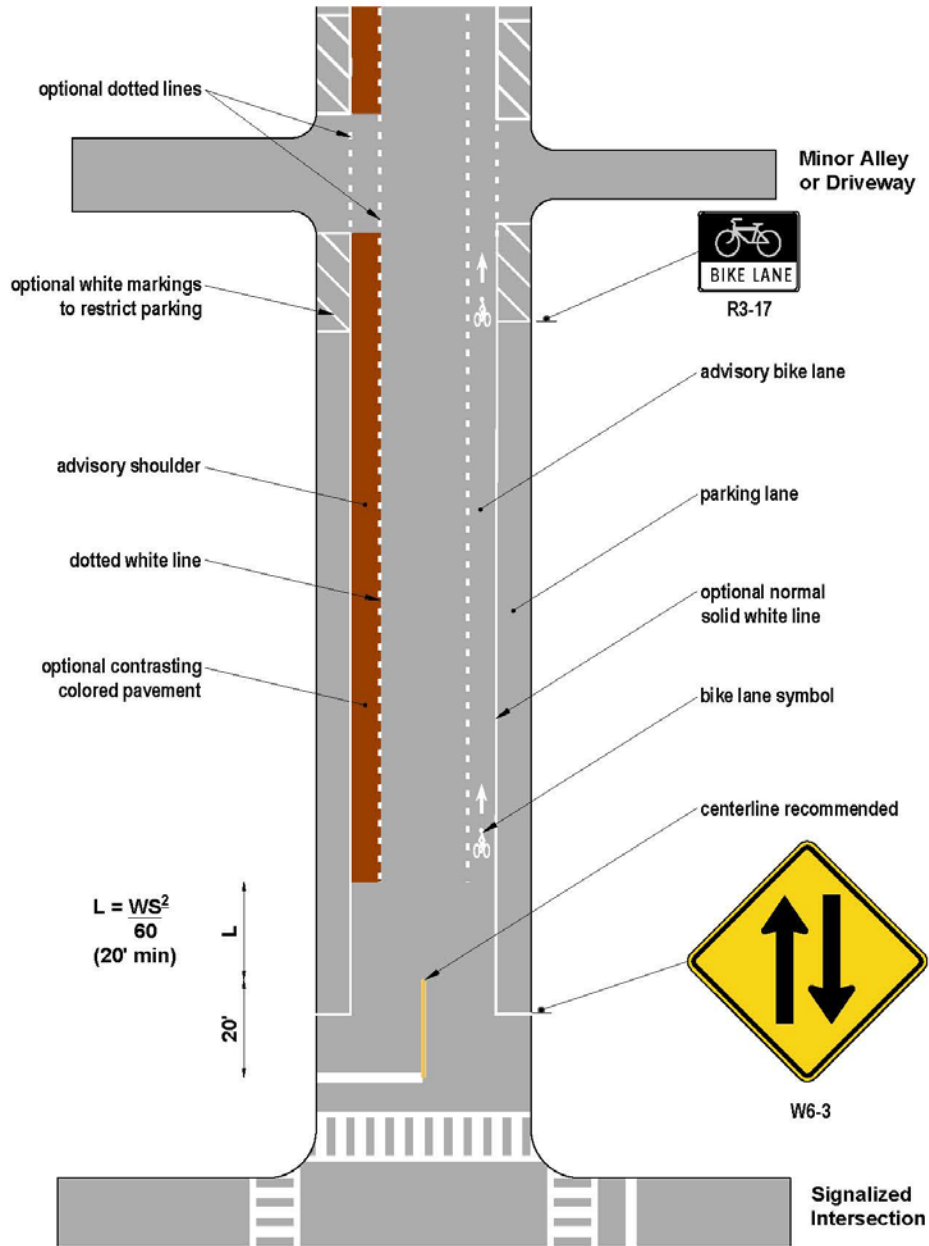

Figure 4-15. Advisory Bicycle Lane Design Guidance

4.5.11 Shared Lane Markings

Shared lane markings are pavement markings that denote shared bicycle and motor vehicle travel lanes. The markings are two chevrons positioned above a bicycle symbol, placed where the bicyclist is anticipated to operate. This is a design solution that should only be used in locations with low traffic speeds and volumes (3,000 ADT and 25 mph or lower) as part of a signed route or bicycle boulevard. Shared lane markings are sometimes used as a temporary solution on constrained, higher-traffic streets (up to 10,000 vehicles per day) until additional right-of-way can be acquired, but should not be considered a permanent solution in these contexts. Only Activity Streets and Commerce/Mixed-Use Streets provide this option, and any section on these Street Types that does not include an explicit bicycle facility (either on-street or off-street) is intended to operate as a shared facility. Generally, on non-neighborhood streets, shared lane markings will have higher LTS scores due to lack of separation and increased exposure to motor vehicle traffic volumes.

4.5.11.1 Considerations

- Typically used on local, collector, or minor arterial streets with low traffic speeds and volumes. Commonly used on bicycle boulevards to reinforce the priority for bicyclists.
- Typically feasible within existing right-of-way and pavement width even in constrained situations that preclude dedicated facilities.
- May be used as interim treatments to fill gaps between bicycle lanes or other dedicated facilities for short segments where there are space constraints.
- May be used for downhill bicycle travel in conjunction with climbing lanes intended for uphill travel.
 - Typical signage may include: BICYCLES MAY USE FULL LANE (R4-11).
 - Custom signage may include language instructing drivers to change to lanes to pass or use a 3-foot passing distance.

4.5.11.2 Guidance

- Intended for use only on streets with posted and operating speeds of up to 25 mph and traffic volumes of less than 3,000 vehicles per day. Maximum posted speed of street: 30 mph.
- May be used as a temporary solution on constrained streets with up to 10,000 vehicles per day until a more appropriate bikeway facility can be implemented. Maximum posted speed of street: 30 mph.
- Intended for use on lanes up to 14 feet wide (up to 13 feet preferred). For lanes 15 feet wide or greater, stripe a 5-foot bicycle lane instead
- The marking's centerline must be at least 4 feet from curb or edge of pavement where parking is prohibited.
- The marking's centerline must be at least 11 feet from curb where parking is permitted, so that it is outside the door zone of parked vehicles.
- For lanes 12 feet or less, it may be desirable to center shared lane markings along the centerline of the outside travel lane.

Figure 4-16 shows the placement of shared lane markings.

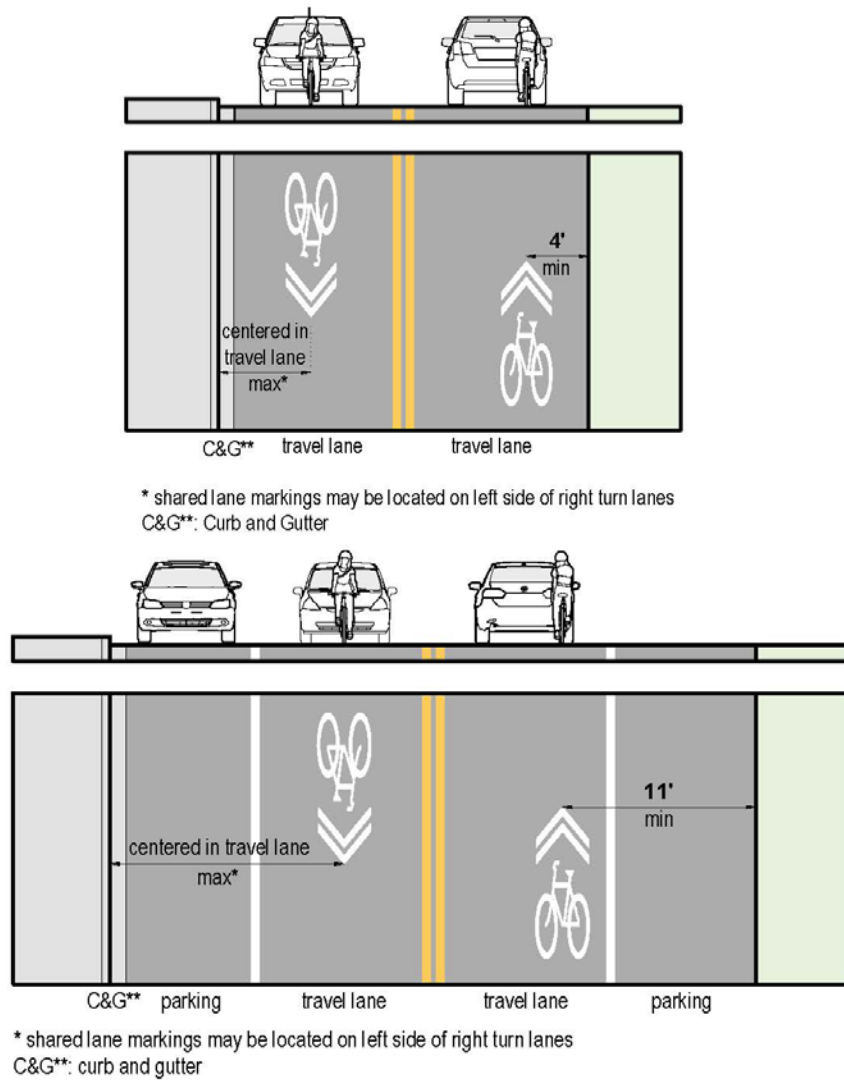

Figure 4-16. Design Guidance for Shared Lane Markings

4.5.12 Transitions Between Bicycle Facilities

Facility types may vary along a roadway corridor based on land use, parking needs, right-of-way constraints, and other characteristics. Additionally, a common or logical route for bicyclists may turn at an intersection. It is important to provide transitions between different types of facilities (e.g., wayfinding signage, pavement markings, turn-queue boxes). **Figure 4-17** shows the preferred layout for transitioning between a separated bike lane to a shared bike lane.

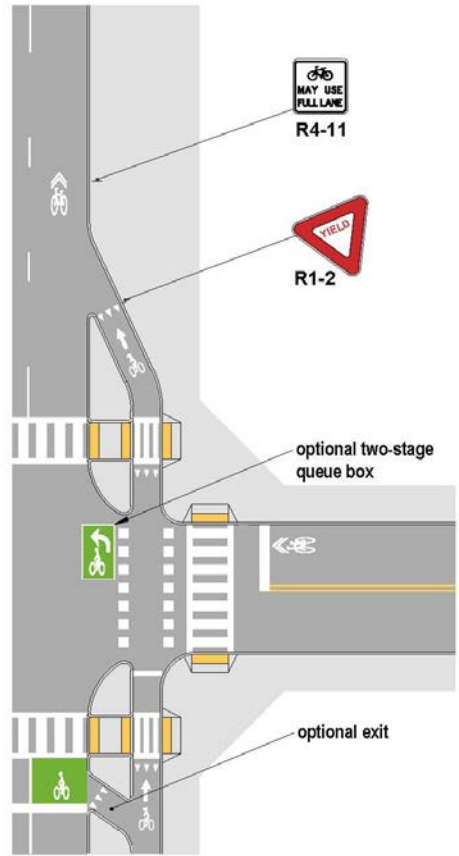

Figure 4-17. Preferred Design of a Separated Bike Lane Transition to a Shared Bike Lane

4.5.12.1 Considerations

- Planning for appropriate connections and transitions between facility types should be conducted as a part of network planning. Facilities must have logical termini and a network should be planned to serve a range of users.
- Enhance visibility with green pavement markings and/or bicycle symbols at conflict locations.
- Two-stage left turn movements can be accommodated using two-stage turn queue boxes. These movements can be easier for some bicyclists to execute. Two-stage left turns may be more comfortable for many bicyclists because the maneuver does not require waiting for gaps in the adjacent same-direction traffic stream before merging laterally to reach a left-turn lane.

4.5.12.2 Guidance

- Always carry bicycle facilities to a logical terminus. Specifically, designers should avoid abruptly ending facilities without considering transitions and interactions with vehicles.
- At locations where bicycle lanes transition to shared lanes, it may be desirable to provide a transition to a short segment of shared lane markings, even if the shared lane markings will not continue.

- Signage should be provided per guidance in the latest edition of the [TMUTCD](#) and [AASHTO Guide for the Development of Bicycle Facilities](#). Pavement markings should alert motorists of the change in facility and intended shared-use of travel lanes.
- Taper lengths for lane drops and transitions should follow the [TMUTCD](#) and AASHTO Green Book recommendations.
- Bicycle boxes and turn-queue boxes should be placed out of vehicle paths and be wide/long enough to support multiple bicyclists queuing at intersections. Bicycle boxes should only be used where a dedicated facility is provided prior to the intersection (bicycle lane); however, queue boxes may be used at a variety of locations with or without dedicated facilities.

4.5.13 Transition from One-Way Separated Bicycle Lane to Conventional Bicycle Lane on Same Street

Figure 4-18 shows the preferred layout of transitioning for a separated bicycle lane to a conventional bicycle lane.

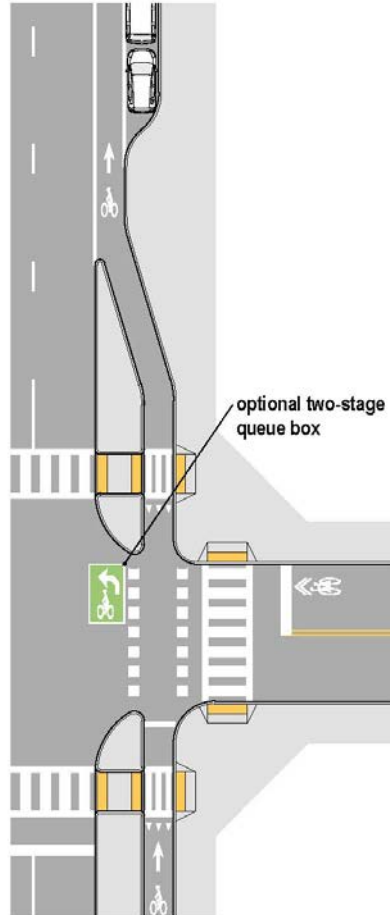

Figure 4-18. Preferred Design of a Separated Bicycle Lane Transition to a Conventional Bicycle Lane

4.5.13.1 Considerations

To convey which user has the right of way, intersections with separated bicycle lanes should be designed to minimize bicyclist exposure to motorized traffic and should minimize the speed differential at conflict points. The goal is to provide clear messages regarding right of way to all users moving through the intersection in conjunction with geometric features that result in higher compliance where users are expected to yield.

The transition should:

- Maintain separation through the intersection.
- Occur on the far side of intersections to reduce conflicts with turning vehicles within the intersection.

- Maintain a vertical or visual separation between bicyclists and pedestrians where sidewalk buffers are eliminated.
- Clearly communicate how bicyclists should enter and exit the separated bicycle lane minimizing conflicts with other users.

4.5.13.2 *Guidance*

- Maximum 3:1 lateral taper.
- A bicycle lane width of 6.5 feet is required to allow passing.
- A protecting island should be provided to shadow the bicycle lane on the far side and to create protection for queueing left turn bicyclists waiting in the turn box.
- Provide a two-stage turn queue box at intersections with cross streets that have bicycle lanes or shared lanes.
- Minimum offset is 6 feet, desirable 16.5 feet.

4.5.14 Transition from Two-Way Separated Bicycle Lane to One-Way Separated Bicycle Lane on Intersecting Street

Figure 4-19 shows the preferred layout for transitioning between a two-way separated bicycle lane to a one-way separated bicycle lane on a cross street.

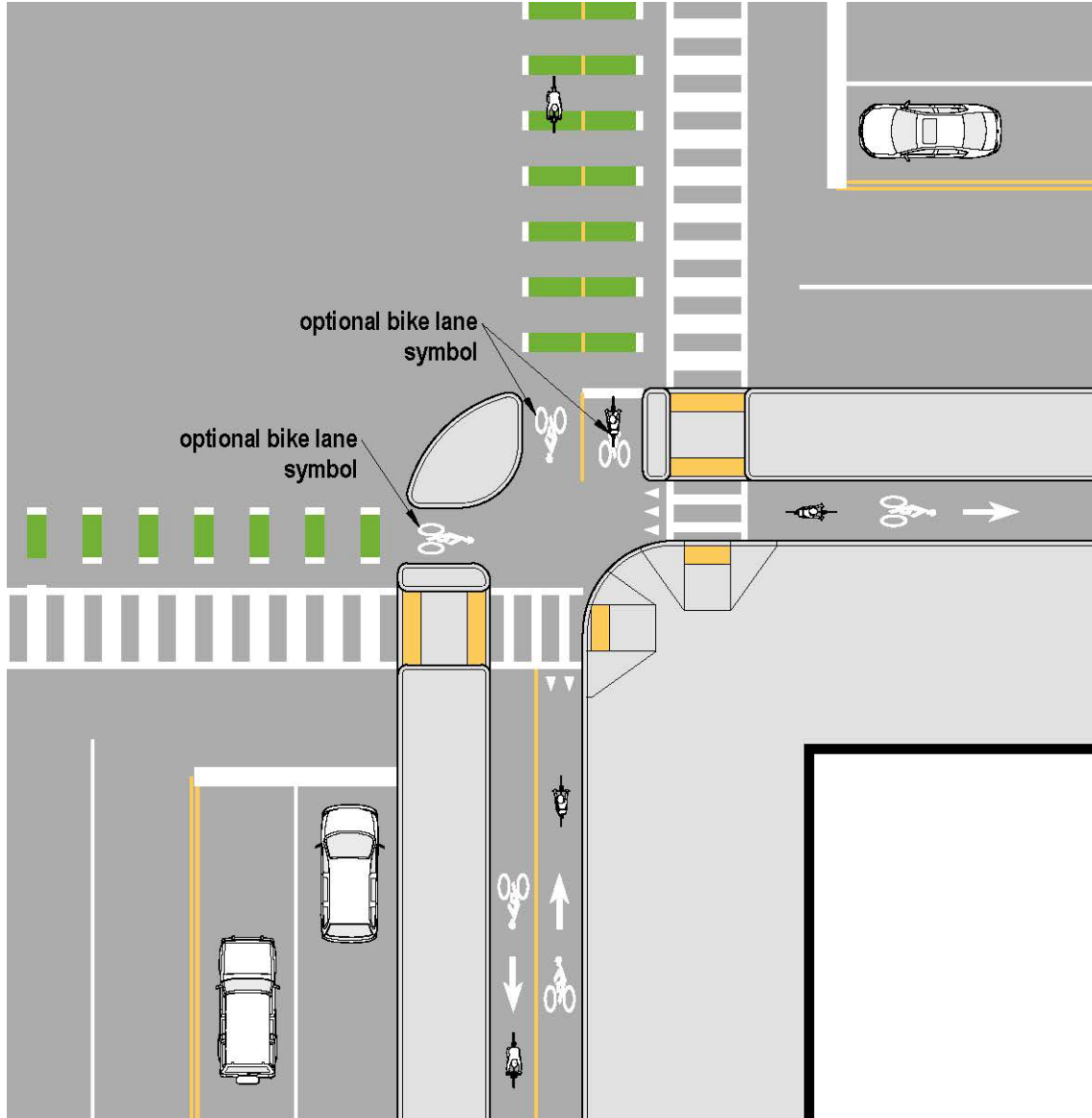

Figure 4-19. Preferred Design of a Two-Way Separated Bicycle Lane Transition to a One-Way Separated Bicycle Lane on a Cross Street

4.5.14.1 Considerations

Intersections with separated bicycle lanes should be designed to minimize bicyclist exposure to motorized traffic and should minimize the speed differential at the points where travel movements intersect. The goal is to provide clear messages regarding right of way to all users moving through

the intersection in conjunction with geometric features that result in higher compliance where users are expected to yield.

The transition design should:

- Maintain separation through the intersection.
- Occur on the far side of intersections to reduce conflicts with turning vehicles within the intersection.
- Maintain a vertical or visual separation between bicyclists and pedestrians where sidewalk buffers are eliminated.
- Clearly communicate how bicyclists are intended to enter and exit the separated bicycle lane minimizing conflicts with other users.

4.5.14.2 *Guidance*

- A minimum two-way separated bicycle lane width of 10 feet is recommended.
- A minimum one-way separated bicycle lane width of 6.5 feet is recommended.
- A 15-foot corner radius is recommended for turns from the two-way bicycle lane onto the one-way bicycle lane.
- Minimum offset is 6 feet, desirable 16.5 feet.
- A minimum street buffer of 6 feet is recommended.

4.5.15 Transition between One-Way Separated Bicycle Lanes at an Intersection

Figure 4-20 shows the preferred layout for transitioning between one-way separated bicycle lanes at an intersection.

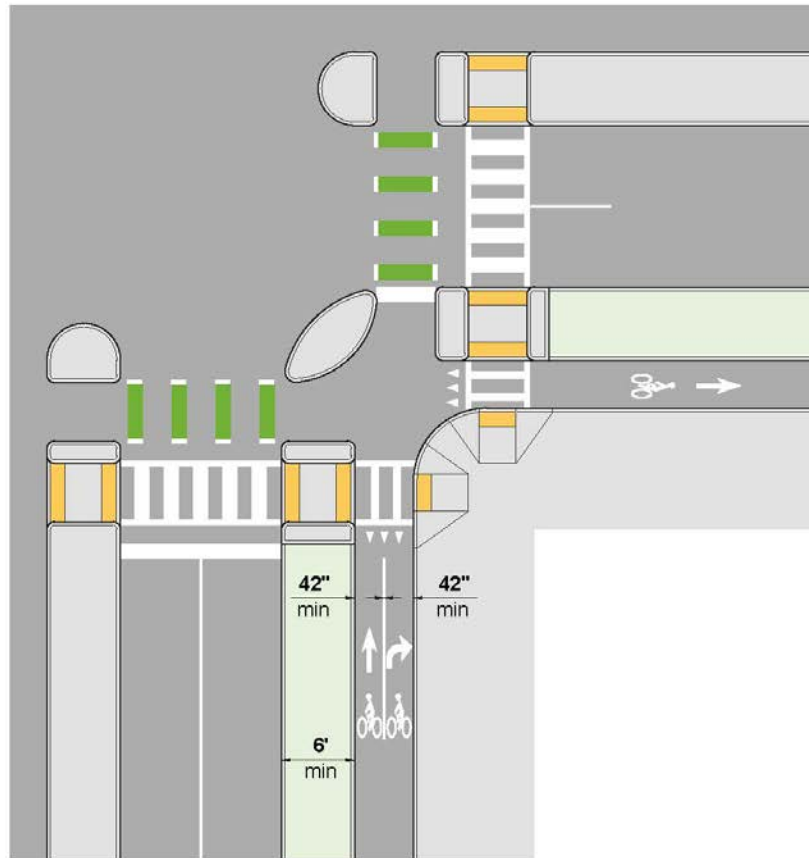

Figure 4-20. Preferred Design of a One-Way Separated Bicycle Lane Transition to a One-Way Separated Bicycle Lane on a Cross Street.

4.5.15.1 Considerations

Intersections with separated bicycle lanes should be designed to minimize bicyclist exposure to motorized traffic and should minimize the speed differential at the points where travel movements intersect. The goal is to provide clear messages regarding right of way to all users moving through the intersection in conjunction with geometric features that result in higher compliance where users are expected to yield.

The transition design should:

- Maintain separation through the intersection.
- Occur on the far side of intersections to reduce conflicts with turning vehicles within the intersection.
- Maintain a vertical or visual separation between bicyclists and pedestrians where sidewalk buffers are eliminated.

- Clearly communicate how bicyclists are intended to enter and exit the separated bicycle lane minimizing conflicts with other users.

4.5.15.2 *Guidance*

- A minimum one-way separated bicycle lane width of 6.5 feet is recommended.
- A minimum street buffer of 6 feet is recommended.
- Minimum offset is 6 feet, desirable 16.5 feet.
- Recommended minimum transition is 25 feet to ensure a bicyclist has time to react to an approaching vehicle.
- A one-way separated bicycle lane and conventional bicycle lane width of 6.5 feet is recommended.
- Maximum 3:1 lateral taper.

4.6 ENHANCEMENTS AND SUPPORTING TREATMENTS FOR BICYCLE FACILITIES

4.6.1 Bicycle Boulevard Treatments

Bicycle boulevards incorporate traffic calming treatments with the primary goal of prioritizing bicycle through-travel, while discouraging excessive motor vehicle traffic and maintaining relatively low motor vehicle speeds. These treatments are applied on quiet, well connected streets, often through residential neighborhoods. Treatments vary depending on context, but often include traffic diverters, speed attenuators such as speed humps or chicanes, pavement markings, and signs. Bicycle boulevards are also known as neighborhood greenways and neighborhood bikeways, among other locally-preferred terms. **Table 4-4** shows the threshold traffic volumes for bicycle boulevard treatments.

Table 4-4. Traffic Volume Thresholds for Bicycle Boulevard Treatments

Minimize Motorized Through Traffic Volumes and Speed Differential			
	Hourly Traffic Volume	Daily Traffic Volume	Speed
Preferred	50 vehicles/hr	1,000 ADT	15 mph
Acceptable	75 vehicles/hr	2,000 ADT	20 mph
Maximum	100 vehicles/hr	3,000 ADT	25 mph

4.6.1.1 Considerations

Many cities already have signed bicycle routes along neighborhood streets that provide an alternative to traveling on high-volume, high-speed arterials. Applying bicycle boulevard treatments to these routes makes them more suitable for bicyclists of all abilities and can increase comfort and reduce crashes.

Stop signs or traffic signals should be placed along the bicycle boulevard in a way that prioritizes the bicycle movement, minimizing stops for bicyclists whenever possible. To discourage motorist use of the bicycle boulevard they are diverted out of the street every 4th or 5th block using the tools described in the paragraph below.

Bicycle boulevard treatments include traffic calming measures such as street trees, traffic circles, chicanes, and other horizontal speed controls. Traffic management devices such as diverters or semi-diverters can redirect cut-through vehicle traffic and reduce traffic volume, while still enabling local access to the street.

Communities should begin by implementing bicycle boulevard treatments on one pilot corridor to measure the impacts and gain community support. The pilot program should include before-and-after crash studies, motor vehicle counts, and bicyclist counts on both the bicycle boulevard and parallel streets. Findings from the pilot program can be used to support bicycle boulevard treatments on other neighborhood streets.

Additional treatments for major street crossings may be needed, such as median refuge islands, bicycle signals, RRFBs and HAWK or half signals. For more information on Traffic Calming treatments supporting bicycle boulevards, see **Chapter 3** of this manual.

4.6.1.2 *Guidance*

- Maximum Average Daily Traffic (ADT): 3,000
- Preferred ADT: Up to 1,000
- Target speeds for motor vehicle traffic are typically around 20 mph; there should be a maximum 10 mph speed differential between bicyclists and vehicles.

4.6.2 **Roundabout Treatments**

Treatments at roundabouts can increase safety for bicyclists and pedestrians. Specific treatments to improve bicyclist and pedestrian safety include speed reducing angled bicycle ramps, median refuge islands, and design methods that reduce vehicle speeds and crossing distances for bicyclists and pedestrians.

4.6.2.1 *Considerations*

- Maintain circle visibility with pavement markings and reflectors.
- Regulatory and/or warning signage should be provided to remind traffic to proceed counter-clockwise around the circle.

4.6.2.2 *Guidance*

- Roundabouts should include features such as bicycle access ramps, that encourage bicyclists to slow and use the sidewalk or shared-use path and navigate the roundabout using marked crossings.
- Pedestrian crossings should be set from yield lines by at least one vehicle length.
- Crosswalks should be marked to clarify where pedestrians should cross and that they have priority. ADA-compliant ramps and detectable warnings are required.

4.6.3 **Crossing Treatments**

While the street segments of a bicycle boulevard or other traffic-calmed street may be comfortable for bicyclists without significant improvement, major street crossings must be addressed to provide safe, convenient, and comfortable travel along the entire route. Treatments provide waiting space for bicyclists, control cross traffic, or ease bicyclist use by removing traffic control for travel along the bicycle boulevard route. A few examples are shown in **Figure 4-21**.



Figure 4-21. Bicycle Box with Lead-In Bicycle Lane, HAWK Beacon

4.6.3.1 Considerations

- Adjustments to traffic control, such as a HAWK signal, Rectangular Rapid Flashing Beacon (RRFB), or stop sign adjustments may require a traffic study.
- Median islands may be constructed to require right-in/right-out turns by motor vehicles while still allowing left turns by bicyclists at offset intersections.
- Numerous treatments exist to accommodate offset intersection crossings for bicyclists, and the full range of design treatments should be considered in these situations. These treatments include left turn queue boxes, two-way center left turn lanes (optionally designed solely for bicyclists), median left turn pockets and short side path segments.

4.6.3.2 Guidance

Medians should be a minimum of 6 feet in width, although 8 feet is desirable to allow adequate space for a bicycle.

Consider median treatment at intersections along a bicycle boulevard route in the following situations:

- Unsignalized crossings of arterial or collector streets with high traffic volumes and speeds.
- Offset intersections where the greenway route makes two turns in short succession.

4.6.4 Bicycle Signals, Detection, Actuation

Bicyclists have unique needs at signalized intersections. Bicycle movements may be controlled by the same indications that control motor vehicle movements, by pedestrian signals, or by bicycle-specific traffic signals. The introduction of separated bicycle lanes creates situations that may require leading or protected phases for bicycle traffic, or place bicyclists outside the cone of vision of existing signal equipment. In these situations, signals for bicycle traffic will be required. Based on traffic conditions, consider the value of applying a “hot call” for activating signals. Such practices increase law compliance, and reward bicyclists for using their system, and not attempting to cross in less safe locations. **Figure 4-22** shows examples of bicycle signals.

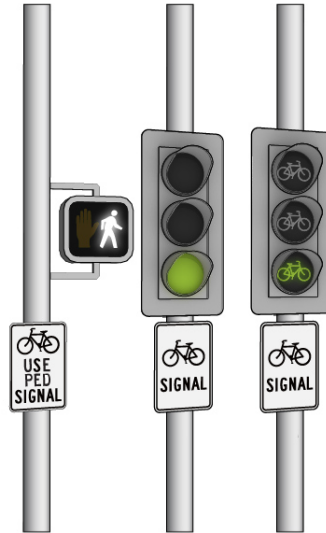

Figure 4-22. Example Bicycle Signals

4.6.4.1 Considerations

- Bicycle-specific signals may be appropriate to provide additional guidance or separate phasing for bicyclists per the [AASHTO Guide for the Development of Bicycle Facilities](#).
- Consider installing advanced bicycle detection on the intersection approach to extend the phase, or to prompt the phase and allow for continuous bicycle through movements.
- Video detection, microwave, and infrared detection can be an alternative to loop detectors.
- Another strategy in signal timing is coordinating signals to provide a “green wave,” such that bicycles will receive a green indication and not be required to stop. Several cities including Denver, CO, Portland, OR, Tucson, Arizona, and San Francisco, CA have implemented “green waves” for bicycles.
- One clear advantage of a “green wave” is that bicyclists already in motion can enter and clear an intersection in as little as 10 seconds, as opposed to 20 seconds of delay to motorists if bicyclists were to come to a full stop.

4.6.4.2 Guidance

- A stationary, or “standing,” cyclist entering the intersection at the beginning of the green indication can typically be accommodated by increasing the minimum green time on an approach per the [AASHTO Guide for the Development of Bicycle Facilities](#).
- A moving, or “rolling,” bicyclist approaching the intersection towards the end of the phase can typically be accommodated by increasing the red time (change and clearance intervals) per the [AASHTO Guide for the Development of Bicycle Facilities](#).
- Set loop detectors to the highest sensitivity level possible without detecting vehicles in adjacent lanes and field check. Type D and type Q loops are preferred for detecting bicyclists.
- Install bicycle detector pavement markings and signs per the [TMUTCD](#), [AASHTO Guide for the Development of Bicycle Facilities](#), and the [NACTO Urban Bikeway Design Guide](#).

4.6.5 Bicycle Boxes

A bicycle box provides dedicated space between the crosswalk and vehicle stop line where bicyclists can wait during the red light at signalized intersections. The bicycle box allows a bicyclist to take a position in front of motor vehicles at the intersection, which improves visibility and motorist awareness, and allows bicyclists to “take the lane” if desired. Bicycle boxes aid bicyclists in making turning maneuvers at the intersection and provide more queuing space for multiple bicyclists than that provided by a typical bicycle lane. **Figure 4-23** shows an example of a bicycle box.



Figure 4-23. Example Bicycle Box

4.6.5.1 Considerations

In locations with high volumes of turning movements by bicyclists, a bicycle box should be used to allow bicyclists to shift towards the desired side of the travel way. Depending on the position of the bicycle lane, bicyclists can shift sides of the street to align themselves with vehicles making the same movement through the intersection.

In locations where motor vehicles can continue straight or cross through a right-side bicycle lane while turning right, the bicycle box allows bicyclists to move to the front of the traffic queue and make their movement first, minimizing conflicts with the turning. When a bicycle box is implemented in front of a vehicle lane that previously allowed right turn on red, the right turn on red movement must be restricted using signage and enforcement following.

4.6.5.2 Guidance

- Bicycle boxes have green pavement markings, are a minimum of 10 feet in depth, and are the width of the entire travel lane(s).

- Bicycle box design should be supplemented with appropriate signage according to the latest version of the [TMUTCD](#).
- Bicycle box design should include appropriate signalization adjustment in determining the minimum green time.
- Where right-turn lanes for motor vehicles exist, bicycle lanes should be designed to the left of the turn lane. If right turns on red are permitted, consider ending the bicycle box at the edge of the bicycle lane to allow motor vehicles to make this turning movement.

4.6.6 Two-Stage Turn Queue Box

A two-stage turn queue box should be considered where bicycle lanes are continued up to an intersection and a protected intersection is not provided. The two-stage turn queue box designates a space for bicyclists to wait while performing a two-stage turn across a street at a location outside the path of traffic. **Figure 4-24** shows the general layout of a two-stage turn queue box with consideration for truck turning movements.

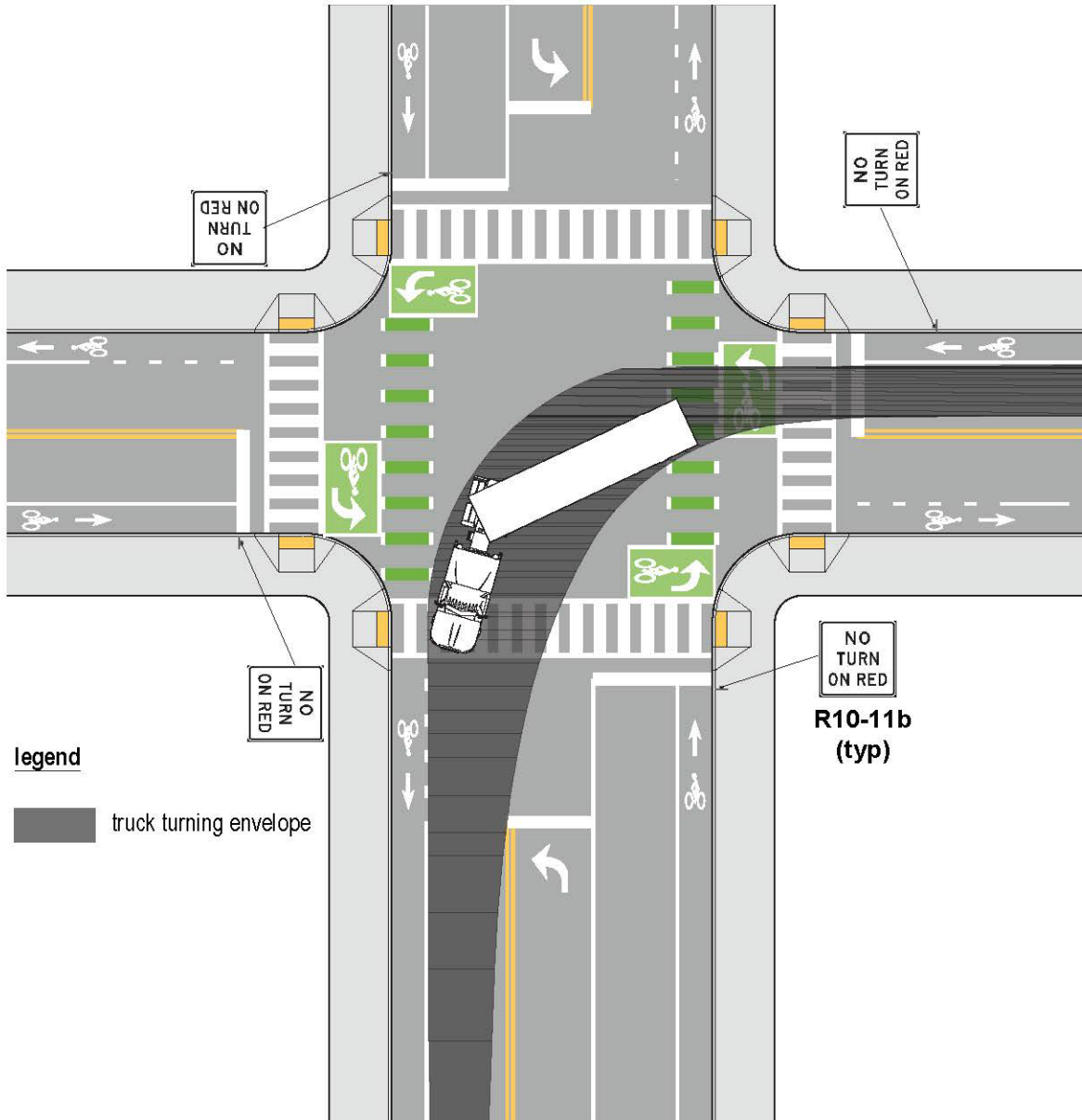

Figure 4-24. Two-Stage Turn Queue Box Design with Consideration of Truck Turning Movements

4.6.6.1 Considerations

FHWA granted interim approval to two-stage turn queue boxes on July 13, 2017. Two-stage turn queue box dimensions will vary based on the street operating conditions, the presence or absence of a parking lane, traffic volumes and speeds, and available street space. The turn box may be placed in a variety of locations including in front of the pedestrian crossing (the crosswalk location may need to be adjusted), in a 'jug-handle' configuration within a sidewalk, or at the tail end of a parking lane or a median island.

4.6.6.2 Guidance

- A minimum width of 10 feet is recommended.
- A minimum depth of 6.5 feet is recommended.
- Dashed bicycle lane extension markings may be used to indicate the path of travel across the intersection.
- NO TURN ON RED (R10-11) restrictions should be used to prevent vehicles from entering the queuing area.
- The use of a supplemental sign instructing bicyclists how to use the box is optional.
- The box should consist of a green box outlined with solid white lines supplemented with a bicycle symbol and a turn arrow to emphasize the crossing direction.

4.6.7 Mixing Zones

A mixing zone requires turning motorists to merge across a separated bicycle lane at a defined location in advance of an intersection. Unlike a standard bicycle lane, where a motorist can merge across at any point, a mixing zone design limits bicyclists' exposure to motor vehicles by defining a limited merge area for the turning motorist. Mixing zones are compatible only with one-way separated bicycle lanes. **Figure 4-25** shows the preferred layout of a mixing zone.

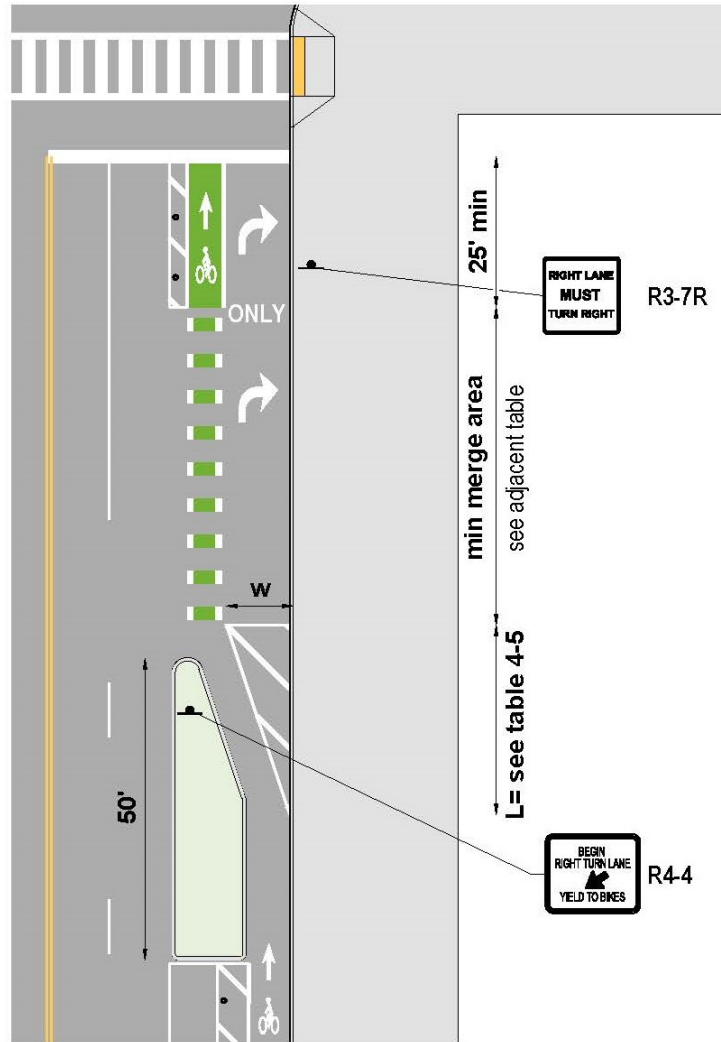

Figure 4-25. Preferred Mixing Zone Design

Table 4-5. Shifting Taper Equation

$L = \frac{WS^2}{60}$		
Where:		
L	=	lane shift (ft), minimum 20 ft
W	=	width of offset (ft)
S	=	target bicyclist operating speed (mph)

4.6.7.1 Considerations

Protected intersections are preferable to mixing zones. Mixing zones are generally appropriate as an interim solution or in situations where severe right-of-way constraints make it infeasible to provide a protected intersection.

Mixing zones are only appropriate on street segments with one-way separated bicycle lanes. They are not appropriate for two-way separated bicycle lanes due to the contra-flow bicycle movement.

4.6.7.2 Guidance

- Locate merge points where the entering speeds of motor vehicles will be 20 mph or less by minimizing the length of the merge area and locating the merge point as close as practical to the intersection.
- Minimize the length of the storage portion of the turn lane.
- Provide a buffer and physical separation (e.g., flexible delineator posts) from the adjacent through lane after the merge area, if feasible.
- Highlight the conflict area with green surface coloring and dashed bicycle lane markings or shared lane markings placed on a green box.
 - Provide a BEGIN RIGHT (or LEFT) TURN LANE YIELD TO BICYCLES sign (R4-4) at the beginning of the merge area.
 - Restrict parking within the merge area.
 - At locations where raised separated bicycle lanes approach the intersection, the bicycle lane should transition to street elevation at the point where parking terminates.
 - Where posted speeds are 35 mph or higher, or at locations where it is necessary to provide storage for queued vehicles, consider providing a deceleration/storage lane in advance of the merge point.

4.6.8 Through Bicycle Lane Approach

A through bicycle lane requires turning motorists to merge across a bicycle lane at a defined location in advance of an intersection. A through bicycle lane design reduces potential for “right hook” and limits bicyclists’ exposure to motor vehicles by defining a limited merge area for the turning motorist. **Figure 4-26** shows the preferred layout of a through bicycle lane at an approach.

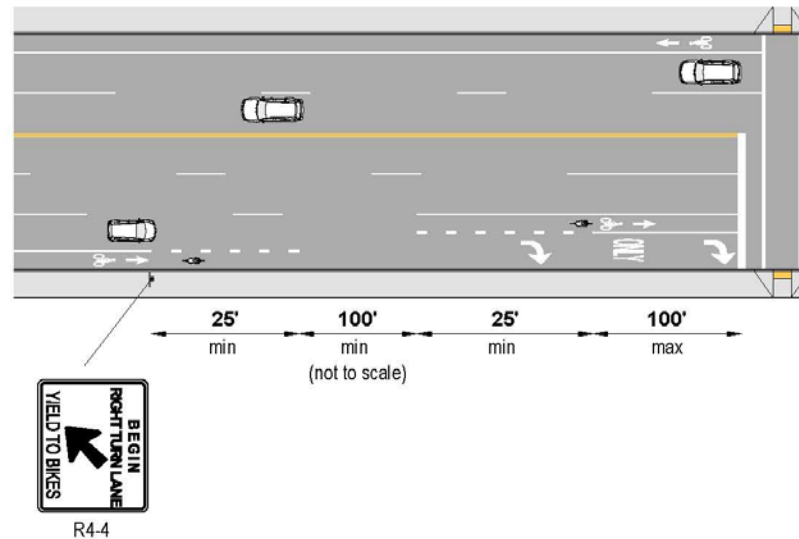

Figure 4-26. Preferred Design of a Through Bicycle Lane Approach

4.6.8.1 Considerations

Through lanes for bicyclists should be used where right turn only lanes exist. Pavement markings should be dotted lines or green dashes to define the merging space. The desired width of the bicycle lane should be 6 feet and a minimum width of 4 feet.

4.6.8.2 Guidance

- Locate merge points where the entering speeds of motor vehicles will be 20 mph or less by minimizing the length of the merge area and locating the merge point as close as practical to the intersection.
- Minimize the length of the storage portion of the turn lane.
- Use a bicycle lane symbol to designate that portion of street for bicyclists.
- Highlight the conflict area with green surface coloring and dashed bicycle lane markings or shared lane markings placed on a green box.
 - Provide a BEGIN RIGHT (or LEFT) TURN LANE YIELD TO BICYCLES sign (R4-4) at the beginning of the merge area.
 - Restrict parking within the merge area
 - Where posted speeds are 35 mph or higher, or at locations where it is necessary to provide storage for queued vehicles, consider providing a deceleration/storage lane in advance of the merge point.

4.6.9 Conflict Area Marking

Conflict area markings are intersection pavement markings designed to improve visibility, alert all roadway users of expected behaviors, and to reduce conflicts with turning vehicles. **Figure 4-27** shows different conflict area markings.

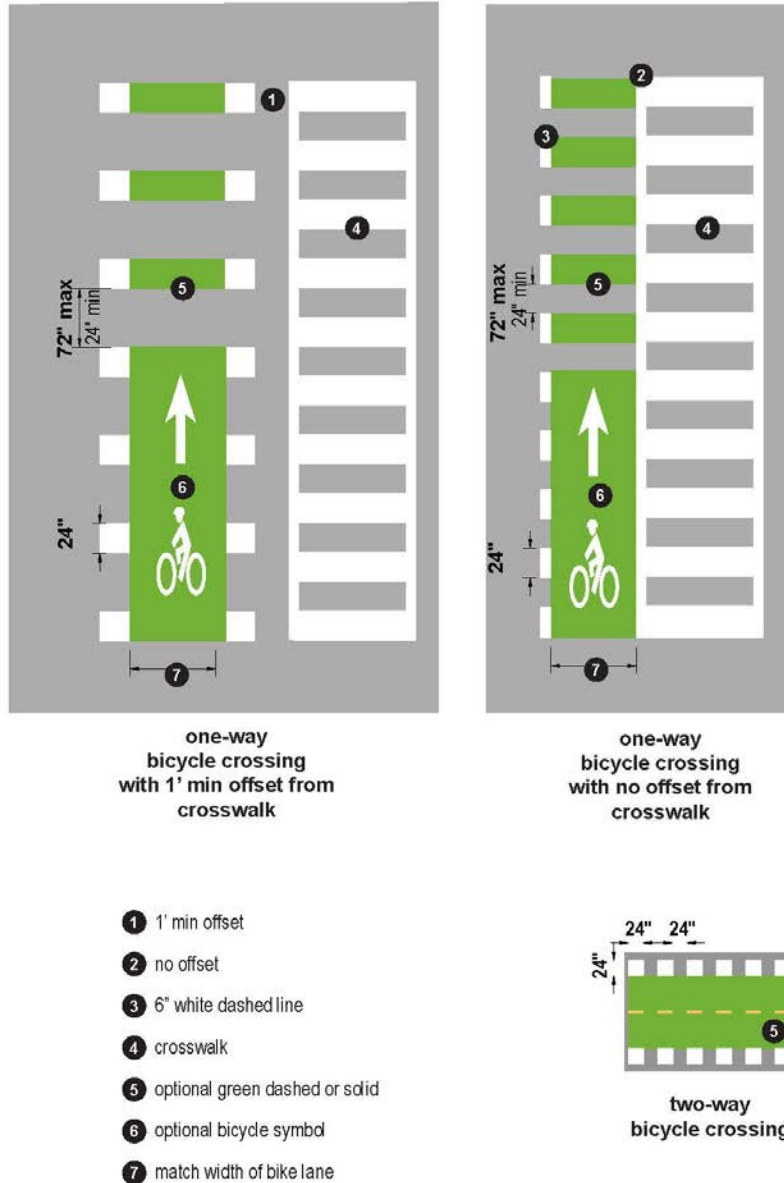

Figure 4-27. Dotted Line Extensions, Bicycle Lane Markings, Colored Conflict Area, Colored Dash, Elephant's Feet

4.6.9.1 Considerations

- The appropriate treatment for conflict areas can depend on the desired emphasis and visibility. Dotted lane lines may be sufficient for guiding bicyclists through intersections; however, consider providing enhanced markings with green pavement and/or symbols at complex intersections or at intersections with safety concerns.
- Symbol placement within intersections should consider vehicle wheel paths and minimize maintenance needs associated with wheel wear.
- Driveways with higher volumes may require additional pavement markings and signage.
- Consideration should be given to using intersection conflict markings as spot treatments or standard intersection treatments. A corridor treatment can maintain consistency; however, spot treatments can be used to highlight conflict locations.

4.6.9.2 Guidance

- The width of conflict area markings should be as wide as the bicycle lanes on either side of the intersection.
- Dotted white lane lines should conform to the latest edition of the [TMUTCD](#). These pavement markings can be used through different types of intersections based on engineering judgment.
- A variety of pavement marking symbols can enhance intersection treatments to guide bicyclists and warn of potential conflicts.
- Green pavement markings may be used along the length of a corridor or in select conflict locations.

4.6.10 Mid-Block Shared-Use Path Crossings

4.6.10.1 Considerations

Crossings that are not located precisely at an intersection are generally not recommended because motorists are presented with multiple conflicts as they prepare to navigate the intersection, and traffic queues may block the crossing. However, sometimes this type of crossing is unavoidable.

Where the crossing cannot be relocated it is preferable to make it as safe as possible because users are unlikely to take a detour, and they are more likely to cross at that location regardless of signs and pavement markings that indicate otherwise. This is particularly true for shared-use paths. Crossing islands can be particularly beneficial in these locations because they enable users to cross one direction of traffic at a time.

4.6.10.2 Guidance

It is preferable for crossings to be as close to 90 degrees as possible to minimize the crossing distance and maximize sight lines. Retrofitting skewed shared-use path crossings can reduce the roadway exposure for path users. **Figure 4-28** depicts a shared-use path realignment to achieve a 90-degree crossing. A minimum 60-degree crossing may be acceptable to minimize right-of-way needs.

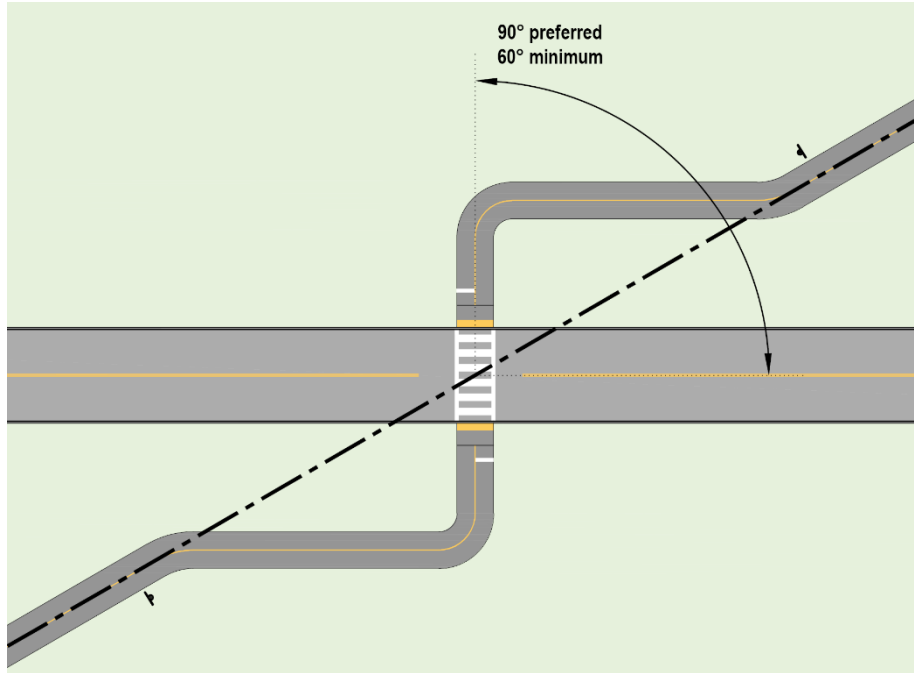
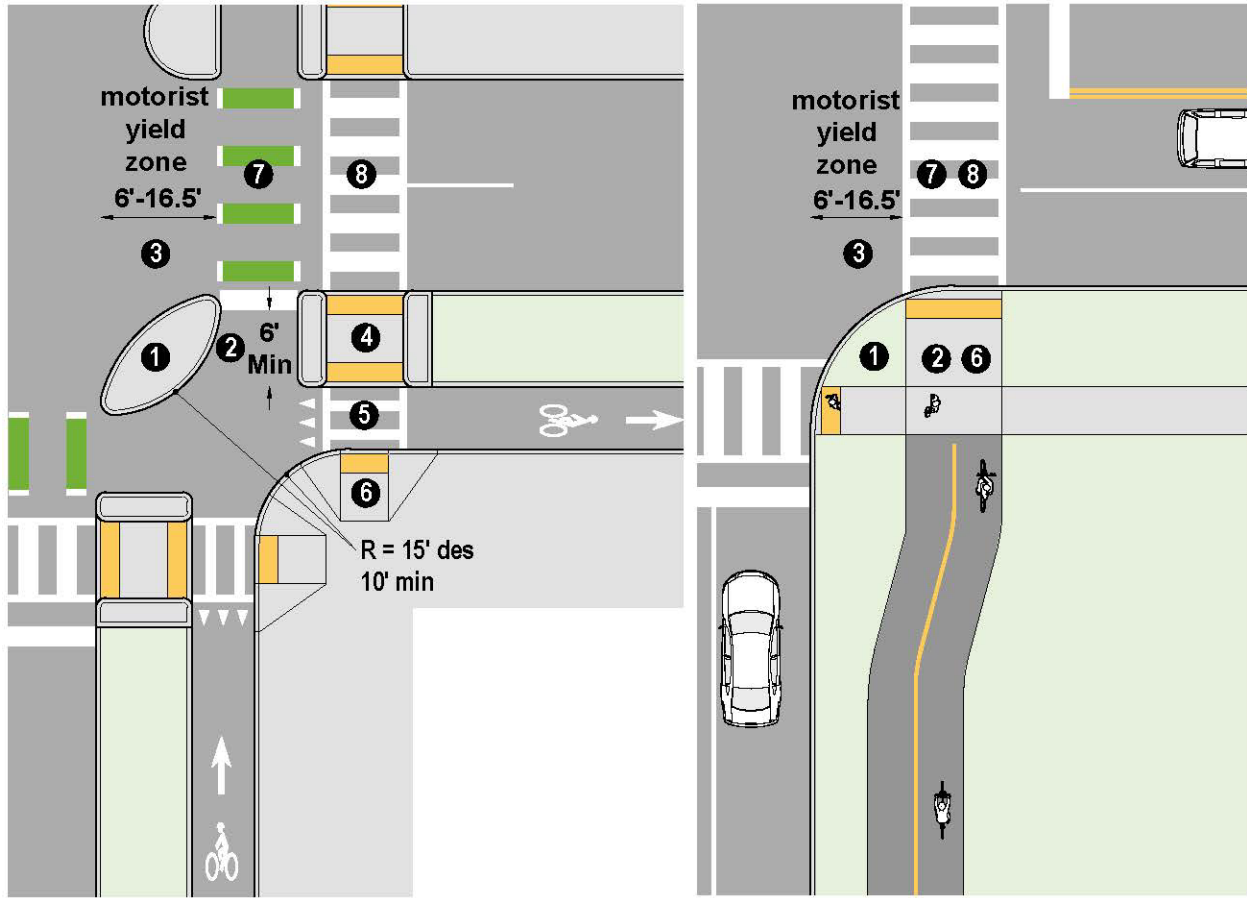

Figure 4-28. A Shared-Use Path Realignment to Achieve a 90-Degree Crossing

4.6.11 Separated Bicycle Lanes at Intersections (Protected Intersections)

Separated bicycle lanes provide an exclusive travel way for bicyclists alongside roadways that is separate from motor vehicle travel lanes, parking lanes, and sidewalks. Separated bicycle lane designs at intersections should manage conflicts with turning vehicles and increase visibility for all users. **Figure 4-29** shows separated bicycle lanes at protected intersections.



- 1 corner island
- 2 forward bicycle queuing area
- 3 motorist yield zone
- 4 pedestrian crossing island
- 5 pedestrian crossing of the separated bike lane
- 6 pedestrian curb ramp
- 7 bicycle crossing of travel lanes
- 8 pedestrian crossing of travel lanes

Figure 4-29. Preferred Protection Intersection Designs

4.6.11.1 Considerations

Separated bicycle lane designs at intersections should consider signal operation and phasing to manage conflicts between turning vehicles and bicyclists. Bicycle signal heads should be considered to separate conflicts.

Shared lane markings and/or colored pavement can supplement short dashed lines to demarcate the protected bicycle lane through intersections, where engineering judgment deems appropriate.

At non-signalized intersections, design treatments to increase visibility and safety include:

- Warning signs
- Raised intersections
- Special pavement markings (including colored surface treatment)
- Parking restrictions in advance of the intersection

4.6.11.2 *Guidance*

- Designs should maintain the separation of the bicycle lane through the intersection rather than introduce the bicyclist into the street with a merge lane. Where this separation is not possible, see guidance on Mixing Zones.
- Increasing visibility and awareness are two key design goals for separated bicycle lanes at intersections. If visibility is a concern, restrict parking within 20 to 40 feet of the intersection to ensure the visibility of bicyclists on the intersection approaches. Use markings and signage at intersections to give priority to separated bicycle lanes.
- Separated bicycle lanes should be routed behind transit stops (i.e., the transit stop should be between the bicycle lane and motor vehicle travel lanes). If this is not feasible, the separated bicycle lane design should include treatments such as signage and pavement markings to alert bicyclists to stop for buses and pedestrians accessing transit stops.

4.6.12 Separated Bicycle Lanes at Roundabouts

When separated bicycle lanes are provided at roundabouts, they should be continuous around the intersection and parallel to the sidewalk. Separated bicycle lanes should follow the contour of the circular intersection. **Figure 4-30** shows an example of a separated bicycle lane at a roundabout.

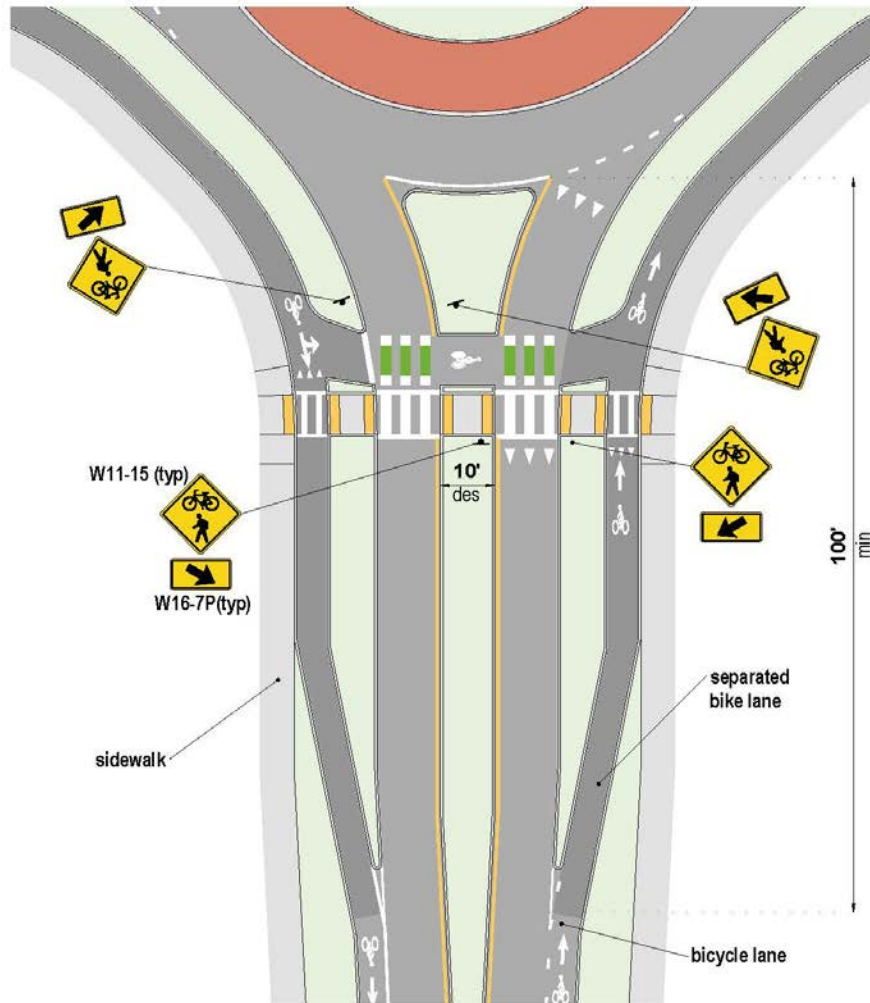

Figure 4-30. Example Design of a Separated Bicycle Lane at a Roundabout

4.6.12.1 Considerations

At crossing locations of multi-lane roundabouts or roundabouts where the exit geometry will result in faster exiting speeds by motorists (thus reducing the likelihood that they will yield to bicyclists and pedestrians), additional measures should be considered to encourage yielding, such as providing an actuated device such as a rapid flashing beacon or pedestrian hybrid beacon.

4.6.12.2 Guidance

- The bicycle crossing should be immediately adjacent to and parallel with the pedestrian crossing, and both should be at the same elevation.

- Consider providing supplemental yield lines at roundabout exits to indicate priority at these crossings.
- The decision of whether to use yield control or stop control at the bicycle crossing should be based on sight distance.
- The separated bicycle lane approach to the bicycle crossing should result in bicyclists arriving at the queuing area at a perpendicular angle to approaching motorists.
- Median designs should apply a “Z” crossing design, whenever median width permits.
- Consider the added value of lean rails.
- Curb radii should be a minimum of 5 feet to enable bicyclists to turn into the queuing area.
- Channelizing islands are preferred to maintain separation between bicyclists and pedestrians but may be eliminated if different surface materials are used.

4.6.13 Separated Bicycle Lanes at Driveways

Most bicycle facilities need to cross streets, driveways, or alleys at multiple locations along a corridor. At these locations, the crossings should be designed to 1) delineate a preferred path for people bicycling through the intersection with the driveway and 2) to encourage driver yielding behavior. Bicycle crossings may be supplemented with green pavement, yield lines, and/or regulatory signs. **Figure 4-31** shows an example of a separated bicycle lane at a driveway.

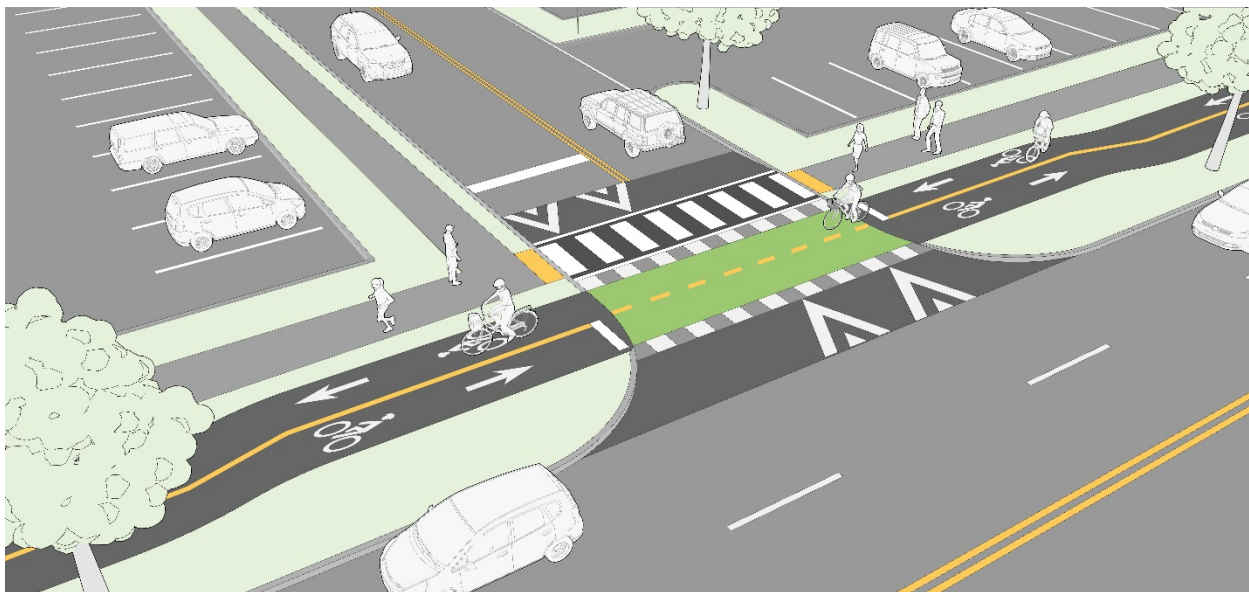

Figure 4-31. Example Design of a Separated Bicycle Lane at a Driveway

4.6.13.1 Considerations

- Supplemental yield lines, otherwise known as shark's teeth, can be used to indicate priority for people bicycling and may be used in advance of unsignalized crossings at driveways, at signalized intersections where motorists may turn across a bicycle crossing during a concurrent phase, and in advance of bicycle crossings located within roundabouts.
- Raised bicycle crossings further promote driver yielding behavior by slowing their speed before the crossing and increasing visibility of people bicycling.

4.6.13.2 Guidance

- The bicycle crossing may be bounded by 12-inch (perpendicular) and 24-inch (parallel) white pavement dashes, otherwise known as elephant's feet. Spacing for these markings should be coordinated with zebra, continental, or ladder striping of the adjacent crosswalk.
- The bicycle crossing should be 6 feet minimum in width for one-way travel and 10 feet minimum in width for two-way travel, measured from the outer edge of the elephant's feet. Bicycle lane symbol markings should be avoided in bicycle crossings. Directional arrows are preferred within two-way bicycle crossings.
- Dashed green colored pavement may be utilized within the bicycle crossing to increase the conspicuity of the crossing where permitted conflicts occur. Green color may be desirable at crossings where concurrent vehicle crossing movements are allowed, and where sightlines are constrained, or where motor vehicle turning speeds exceed 10 mph.

4.6.14 Bridge Design

Bridge crossings are significant investments and therefore typically occur infrequently. However, bridges provide critical access linkages in a community; and when they are designed, it is important that they accommodate pedestrians and bicyclists as shown in **Figure 4-32**. A bridge without walking and bicycling access can result in a lengthy detour that discourages the trip or requires the use of unsafe facilities.



Figure 4-32. Bridges Accommodating Pedestrians and Bicyclists

4.6.14.1 Considerations

Accommodations for pedestrian and bicycle travel should be provided on both sides of bridges. These facilities should be bi-directional where possible, to increase mobility and limit the need for vulnerable road users to cross the street. When planning for bicycle and pedestrian facilities on or beneath bridges, the facility design should account for existing and projected user volumes. The design should also consider providing separate bicycle and pedestrian accommodations, or combine these uses with a shared-use path.

While an accessible route will be required to access a bridge, stairs may provide a more direct and shorter route, and should be considered to complement the accessible route. Stairs can accommodate bicycles by providing a bicycle channel. The handrail must be designed such that pedestrians are easily able to reach the railing without conflict with the bicycle channel.

Bridges may provide needed connectivity within a community, but opportunities to rebuild them are infrequent. Therefore, when such opportunities arise, the new design should account for all anticipated future uses and connectivity needs. Waterways, railroads, and highways may provide a desirable corridor for future shared-use paths.

4.6.14.2 Guidance

- The desirable clear width for a sidewalk on a bridge is 10 feet, if designated on [MTP](#).
- The minimum width for one-way bicycle travel is 4 feet.
- Shy distances should be accounted for when providing the clear width. 1.5 feet is generally needed to provide shy distance from railings and other vertical objects.
- On bridges that accommodate both vehicular and pedestrian/bicycle travel, crash-tested railings should be installed between the motor vehicle lanes and the bicycle facility.
- Rub rails set at handlebar height should be added to all railings.
- When separate spaces are provided for pedestrians and bicyclists, the heels (not the wheels) go to the bridge edge.
- Independent bridges that are built to accommodate shared-use paths and separated bike lanes have additional requirements along with those listed above.
- Bridges should be designed for pedestrian live loadings. Where maintenance and emergency vehicles may be expected to cross the bridge, the design should accommodate them.
- Designing the edge of the approaching bicycle facility to exactly match into the leading edge of a bridge railing or tunnel wall should be avoided. In locations where it cannot be avoided, conspicuous reflective markers should be placed on the leading edge of the bridge railing.
- Where possible, consider widening the physical entrance to a tunnel, such that bicycles traveling near the edge of the bicycle facility approaching the tunnel have an opportunity to recognize the tunnel's edge constraint and alter their course inward to avoid running into the edge of the tunnel entrance.
- The minimum width of a bridge with a shared-use path or separated bike lane is dependent on the width of the approaches.

- Railing height on bridges should be between 42” and 48” depending on the site location. Bridge approaches and span should not exceed 5% slope to accommodate ADA access.
- The 10-foot “receiving” clear width (from inside of rail or wall to inside of opposite rail or wall) should allow for an additional 2 feet of shy space on each side of the facility.

4.7 IMPLEMENTATION OF BIKEWAY NETWORK

Bicycle networks are often implemented through roadway reconstruction or private development projects, resurfacing, and routing maintenance. For example, narrowing lanes creates space that can be re-allocated to other modes, i.e., wider sidewalks, bicycle lanes, and buffers between cyclists, pedestrians, and motor vehicles. Additionally, roadway reconfiguration can be applied broadly to a wide variety of cross sections where one or more travel lanes are repurposed to provide more space for pedestrians and bicyclists. The [Active Transportation Plan](#) should also be consulted for implementation of the bikeway network. **Figure 4-33** shows the installation of a separated bicycle facility.



Figure 4-33. Installation of a Separated Bicycle Facility

4.7.1 Separated Bicycle Lane Maintenance

Separated bicycle lanes require routine maintenance to ensure they provide safe bicycling conditions. Because of their location on the edge of the roadway, separated bicycle lanes are more likely to accumulate debris in all seasons as shown in **Figure 4-34**. Maintenance is a key design consideration as bicyclists are typically inhibited from exiting separated bicycle lanes, they may have no opportunity to avoid obstacles such as debris, obstructions, slippery surfaces, and pavement damage and defects.



Figure 4-34. A Separated Bicycle Lane with Leaf Debris

4.7.1.1 Considerations

A separated bicycle lane should be maintained in a similar manner as the adjacent roadway, regardless of whether the separated bicycle lane is at street level, slightly raised or sidewalk level. Maintenance of separated bicycle lanes is therefore the responsibility of the public or private agency that is responsible for maintaining the adjacent roadway. This practice may contrast with responsibility for maintaining the adjacent sidewalk, which in some cases will be that of the abutting landowner.

Generally, separated bicycle lane widths of 8 feet or more are compatible with smaller sweepers and plows, but responsible parties may have larger and incompatible maintenance fleets.

Narrower sweepers (approximately 4 feet to 5 feet minimum operating width) may be required to clear one-way separated bicycle lanes.

Restricting Motor Vehicles

The alignment of travel lanes across an intersection or in front of a driveway should be reviewed to ensure that the bicycle facility does not appear to be the receiving lane for motor vehicle traffic. Edge lines, lane extension lines, marked bicycle crossings, and bicycle lane symbol markings can all be used to reinforce the intended user of the bicycle facility.

Trash Collection & Mail Delivery

Where separated bike lanes are introduced, the public, public works staff and contractors should be trained to place garbage bins in the street buffer zone to avoid obstructing the bike lane. Sidewalk buffers may be used to store bins where street buffers are too narrow. Special consideration may be required in separated bike lane design for access to large dumpsters which require the use of automated arms. This may require spot restrictions of on-street parking or curb cuts to dumpster storage to accommodate access.

Sweeping and Debris Removal

For street-level separated bicycle lanes without raised medians, debris can collect in the street buffer area between vertical objects and can migrate into the bicycle lane if not routinely collected. Landscaped areas, including green stormwater infrastructure, can also collect debris and require regular attention. Fine debris can settle into permeable pavement and inhibit surface infiltration unless vacuumed on a routine basis. At a minimum, permeable pavement should be vacuumed several times per year, depending on material type.

4.7.2 Bicycle Parking

Bicycle parking enhances the usefulness of bicycle networks by providing locations for the secure storage of bicycles during a trip. Bicycle parking enables bicyclists to secure their bicycles while enjoying the offerings of a street or patronizing businesses and destinations in the city. Bicycle parking requires far less space than automobile parking — in fact, 10-12 bicycles can typically park in the area needed for a single car. Refer to **Chapter 9** of this manual for information on bicycle parking in transit corridors.

4.7.2.1 Considerations

Bicycle parking consists of a rack that supports the bicycle upright and provides a secure place for locking. Bicycle racks should be permanently affixed to a paved surface. Movable bicycle racks are only appropriate for temporary use, such as at major community gatherings. The number of racks at a site should be determined using the guidelines from the Fort Worth [Zoning Ordinance](#).

On-street bicycle parking is intended for short term use. Bicyclists parking overnight should utilize off-street bicycle parking facilities. Bicyclists typically find a variety of fixed objects in the street to which they lock their bicycles. These include parking meters, tree well fences, lawn fences or other objects. These objects may satisfy the need for bicycle parking, but if this is the intent, they should be designed and located with this use specifically in mind. Otherwise, the use of such objects for parking may indicate insufficient or inappropriately located bicycle parking facilities.

On-street bicycle parking should be considered where there are space constraints on the sidewalk. This can be accomplished by converting an automobile parking space into a bicycle corral.

4.7.2.2 Guidance

- Bicycle racks must provide two points of support for bicycles to prevent locked bicycles from falling over.
- All bicycle parking spaces must be located within a one hundred (100) foot diameter of the primary building entrance.
- Bicycle racks should be further placed where building window transparency is high, offering the parking maximum security.
- A minimum of 4 feet from the required rack dimension should be provided for pedestrian clearance when a rack is placed within a sidewalk or pedestrian right-of-way.
- Bicycle racks must be protected by a physical barrier to prevent parked bicycles from damage by motor vehicles; such barriers include but are not limited to curbs, bollards, curb stops and similar objects.
- All bicycle parking spaces must be hard surfaced and dust free and consist of at minimum a compact gravel base.

4.7.3 On-Street Bicycle Parking

Convenient, secure, and ample bicycle parking is a necessity for encouraging bicycling in Fort Worth. Bicycle parking is typically found on sidewalks; however, in some areas, sidewalk space may be insufficient to support the high demand of bicycle parking in popular destinations.

On-street bicycle parking is an efficient way to use valuable curbside real estate. When multiple bicycle racks are clustered together in a contained area, it is referred to as a bicycle corral. 10-14 bicycles may be parked in the space of a single on-street vehicle parking space, thus allowing more patrons to park immediately in front of businesses and residences.

4.7.3.1 Considerations

- On-street bicycle racks can be at the same grade as the sidewalk, as a parklet style bicycle corral, or at the same grade as the street.
- On-street bicycle racks should be considered where there is high demand for bicycle parking and there is not enough width on the sidewalk to satisfy that demand. Bicycles locked to street trees, parking meters, fences and other street furniture are an indicator of parking need.

4.7.3.2 Guidance

- Bicycle corrals and on-street bicycle parking are generally created by clustering typical bicycle hoops or racks in a compact space.
- Bicycle racks should be permanently affixed to a paved surface. Movable bicycle racks are only appropriate for temporary use.
- City code requires the provision of adequate bicycle parking as part of development projects. On-street bicycle parking may help achieve this requirement and improve bicycle-friendliness.
- Encroachment agreements may be necessary for bike racks placed within the public right-of-way.

Figure 4-35 shows example layouts of on-street bicycle parking.

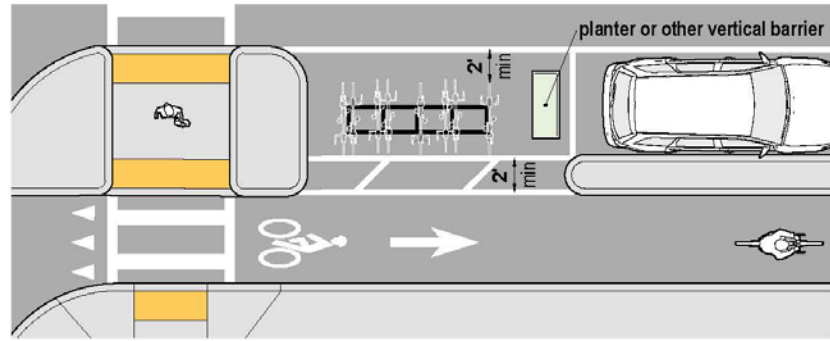

On-Street Bike Parking (Intersection)

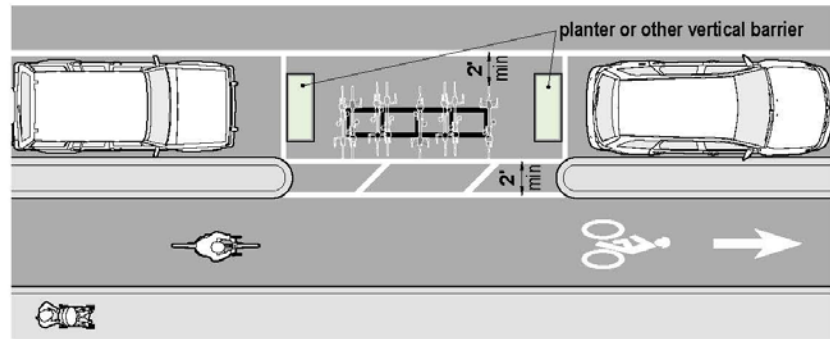

On-Street Bike Parking (Mid-Block)

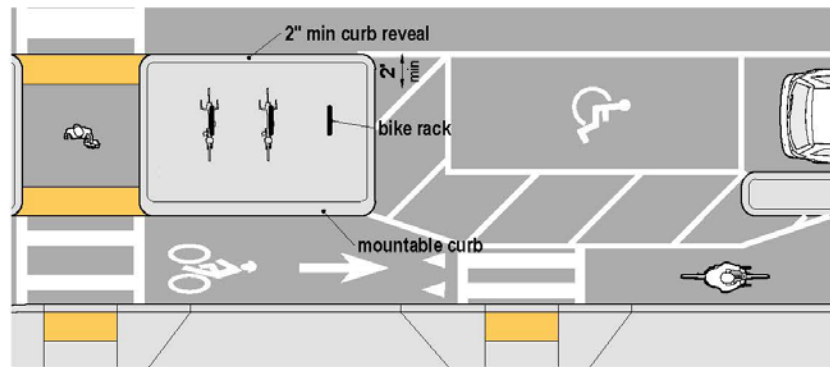

Bike Parking on Raised Median Adjacent to Accessible Car Parking Space

Figure 4-35. Example Designs of On-Street Bicycle Parking

4.7.4 Off-Street Bicycle Parking

Off-street, long-term bicycle parking should be placed in locations with high levels of pedestrian traffic when possible. Placing racks in proximity to security guards or other building personnel or near windows can also improve safety and security. Convex mirrors can improve visibility and minimize blind spots and installing video cameras in bike parking areas and posting signs indicating the presence of the cameras can deter theft.

Bicycle users should be able to ride up to off-street bike parking areas. Bicycle access routes should be delineated through areas such as plazas, parking lots, and parking garages. These routes should be designed according to the recommendations for bicycle facilities in this guide and provide separate space for bicycles and pedestrians.

4.7.4.1 Considerations

- When possible, bike parking should be at ground level. For an underground or higher-level bicycle parking location, such as in a parking garage, a separate, access-controlled, dedicated bicycle ramp should be provided to allow uninterrupted bicycle travel to the bike parking.
- Off-street bicycle parking facilities include:
 - Bicycle rooms
 - Rooms in residential, employment, or transit buildings designed for the purpose of safely parking.
 - Bicycle cages
 - Bicycle cages are controlled-access, enclosed fenced areas that contain bicycle racks. They may be part of a basement, garage, or another room, or may be a stand-alone, outdoor, covered structure.
 - Bicycle lockers
 - Bicycle lockers are self-contained units that store an individual bicycle and related accessories and provide a high level of security.
 - Bicycle stations
 - Bicycle parking stations, also known as bicycle transit centers, bike stations, or cycle stations, are specially-designed buildings or structures for bicycle parking. They may be staffed or unstaffed and may provide additional end-of-trip services, such as repair stations, bike shops, vending machines, lockers or showers.

4.7.4.2 Guidance

- Bike lockers should be constructed from a strong, weather resistant material that does not require maintenance.
- When elevators are necessary, the minimum interior dimensions for elevators to access bicycle parking are 80 in. x 54 in.
- The use of two-tiered racks can provide increased parking capacity in areas with limited space availability. Consider providing a mechanism to assist the user in lifting their bicycle onto the second tier.

4.8 REFERENCES FOR BICYCLE FACILITY DESIGN

- AASHTO Policy on Geometric Design of Highways and Streets (Green Book)
- [AASHTO Guide for the Development of Bicycle Facilities](#)
- [FHWA Shared Use Path Level of Service Calculator](#)
- [Active Transportation Plan](#)
- [Zoning Ordinance](#)

- [Public Right-of-Way Accessibility Guidelines \(PROWAG\)](#)
- [Active Transportation Plan](#)
- [FHWA Separated Bicycle Lane Planning and Design Guide](#)
- [FHWA Bicycle and Pedestrian Facility Design Flexibility](#)
- [Texas Manual on Uniform Traffic Control Devices \(TMUTCD\)](#)
- [Bicycle Facilities and the Manual on Uniform Traffic Control Devices: Dashed Bicycle Lanes](#)
- [FHWA Bicycle Facilities and the Manual on Uniform Traffic Control Devices - Two-Stage Turn Box](#)
- [NCHRP Report 672 – Roundabouts: An Informational Guide](#)
- [NACTO Urban Bikeway Design Guide](#)
- [NACTO Urban Street Design Guide](#)
- [MassDOT Separated Bicycle Lane Planning and Design Guide](#)
- [Evaluation of Innovative Bicycle Facilities: SW Broadway Cycle Track & SW Stark/Oak Street Buffered Bicycle Lanes. Final Report.](#)
- [Fundamentals of Bicycle Boulevard Planning & Design](#)
- [APBP Bicycle Parking Guidelines](#)
- [APBP Essentials of Bicycle Parking: Selecting and Installing Bicycle Parking that Works](#)

Contents

CHAPTER 5 - PEDESTRIAN ZONE 5-3

- 5.1 Introduction 5-3
- 5.2 Legal Framework..... 5-3
- 5.3 Design Specifications by Roadway Type and Land Use 5-4
- 5.4 Sidewalk Space..... 5-6
 - 5.4.1 Frontage Zone 5-7
 - 5.4.1.1 Considerations..... 5-7
 - 5.4.1.2 Guidance 5-8
 - 5.4.2 Sidewalk/Pedestrian Zone..... 5-8
 - 5.4.2.1 Considerations..... 5-8
 - 5.4.2.2 Guidance 5-9
 - 5.4.3 Furnishing Zone 5-9
 - 5.4.3.1 Considerations..... 5-10
 - 5.4.3.2 Guidance 5-10
- 5.5 Landscaping in Parkways..... 5-10
 - 5.5.1 Street Trees and Plantings..... 5-11
 - 5.5.1.1 Considerations..... 5-11
 - 5.5.1.2 Guidance 5-11
 - 5.5.2 Tree Wells..... 5-11
 - 5.5.2.1 Considerations..... 5-11
 - 5.5.2.2 Guidance 5-12
 - 5.5.3 Continuous Planting Strip..... 5-12
 - 5.5.3.1 Considerations..... 5-12
 - 5.5.3.2 Guidance 5-13
- 5.6 Curb Ramps 5-14
 - 5.6.1.1 Considerations..... 5-14
 - 5.6.1.2 Guidance 5-14
- 5.7 Utilities 5-16
 - 5.7.1.1 Overview..... 5-16
 - 5.7.1.2 Considerations..... 5-16
 - 5.7.1.3 Guidance 5-17
- 5.8 Street Furnishings 5-18
 - 5.8.1 Transit Stops..... 5-18
 - 5.8.2 Bike Parking..... 5-18
 - 5.8.3 Seating..... 5-18
 - 5.8.3.1 Overview..... 5-18
 - 5.8.3.2 Considerations..... 5-18
 - 5.8.3.3 Guidance 5-19
 - 5.8.4 Dumpster Location 5-20
- 5.9 Street Lighting 5-20

List of Figures

Figure 5-1. Sidewalk Space 5-7
 Figure 5-2. Café Seating in the Frontage Zone 5-8
 Figure 5-3. Benches, Street Lighting, and Trash Cans in the Furnishing Zone 5-10
 Figure 5-4. Tree Wells in the Furnishing Zone 5-12
 Figure 5-5. Continuous Planting Strips in the Furnishing Zone, Mid-Way, and Frontage Zone Positions 5-13
 Figure 5-6. Example Intersection with Curb Ramps at All Approaches 5-15
 Figure 5-7. Flared Curb Ramp (left) and Non-Flared Curb Ramp (right) 5-16

List of Tables

Table 5-1. Land Uses Along Roadways 5-5
 Table 5-2. Minimum Pedestrian Zone Widths by Roadway Type 5-6

CHAPTER 5 - PEDESTRIAN ZONE

5.1 INTRODUCTION

The area between the curb and the building face is one of the most vibrant and active sections of the overall right-of-way. This zone plays a critical role in the character, function, livability, and accessibility of neighborhoods. Residents of the City value the walkability of their community and neighborhoods and business owners benefit from increased pedestrian traffic. The function and design of the sidewalk and planter/furnishing strip significantly impacts the character of each street, and while typically reserved for pedestrians, they also accommodate street trees, stormwater infrastructure, street lights, street furniture, bicycle racks, and transit stops. Above all, the pedestrian zone, when appropriately designed and accessible to all users, can play a critical placemaking role by providing for a vibrant public life as well as a place for commerce to spill on to through sidewalk cafes and window shopping.

5.2 LEGAL FRAMEWORK

Accessibility requirements influence the minimum functional design and implementation of sidewalks, street crossings, curb ramps, signals, street furniture, transit stations, on-street parking, loading zones, shared use paths, and more. At the network level, connecting accessible pedestrian routes reduces conflicts by providing access across barriers. This enables safe and comfortable walking trips from beginning to end for pedestrians of all abilities.

The U.S. Access Board is the Federal agency responsible for developing and updating accessibility guidelines under the Americans with Disabilities (ADA) of 1990. The Access Board published its [PROWAG](#) in 2011. At the time of publication of this document, the Board had not issued a final [PROWAG](#) rule. [PROWAG](#) will become an enforceable standard only after the Board publishes a final rule and after the U.S. Department of Justice (USDOJ) and/or the U.S. Department of Transportation (USDOT) adopts the final guidelines into their respective ADA and Section 504 of the Rehabilitation Act regulations. Until that time, the [USDOJ 2010 ADA Standards](#), [TAS](#), and Section 504 Standards provide enforceable standards applicable to the public right-of-way.

Where the [USDOJ 2010 ADA Standards](#) or [TAS](#) do not address a specific issue in the public right-of-way, the Federal Highway Administration encourages public entities to look to the draft [PROWAG](#) for best practices. Several jurisdictions have chosen to apply the draft [PROWAG](#) as an alternative to, or equivalent facilitation for, the ADA Standards because they provide more specific coverage of accessibility issues in the public right-of-way. Jurisdictions that have adopted the draft [PROWAG](#) as their standard should consistently apply all provisions of the draft [PROWAG](#). Public entities and/or recipients of Federal financial assistance are responsible for complying with the current ADA and Section 504 accessibility standards and/or demonstrating equivalent facilitation.

5.3 DESIGN SPECIFICATIONS BY ROADWAY TYPE AND LAND USE

The design of streets and roads in the City should reflect the mobility, safety, comfort and economic needs of the people as well as connect local, regional, state, and private networks. This section provides clarity on the application and appropriateness of different design standards within this framework.

The [MTP](#) provides cross-section requirements for the City's thoroughfares, which are “facilities that serve moderate-length to long trips and moderate to high traffic volumes, and typically interconnect with and augment the interstate and state highway systems. Thoroughfares can also include shorter, moderate-volume roadways that provide important connectivity for the City (such as downtown streets), or that carry large amounts of trucks (such as industrial streets).” **Table 5-1** provides descriptions of land uses and pedestrian realm priorities to expect along the different roadway types. **Table 5-2** provides frontage, buffer, and pedestrian zone width guidance for each of the roadway types. On roadways with a right-of-way exceeding the total cross-section width requirement, this additional “flex space” should be transferred to the space behind the curb, to enhance the walking and biking environment.

Table 5-1. Land Uses Along Roadways

Roadway Type	Associated Land Use	Pedestrian Realm Priorities
Local Streets	Residential; Medium-high pedestrian activity; Emphasizes access over mobility; On-street parking; Homes are set back from the street	Accessibility, min. width, street landscape buffer, shade (through street trees) Connect sidewalk to the front entrance of the home
Collectors	Mix of retail and residential; tend to provide throughput of vehicles while still accommodating access to the businesses and properties that line the roadway; expected to balance mobility and access.	Sidewalks are more functional Screening of surface parking areas through vegetative buffers More informal arrangement of landscaping and sidewalks may be more naturally winding
Activity Streets	Small and medium sized businesses; Occasional residential; Heavy pedestrian activity; Transit use; On-street parking; Buildings are typically one to three stories high and are closer to the sidewalk with parking in the side of the building or in the rear of the lot	Wider sidewalks and shade elements at transit stops Street buffer may be hardscaped with trees in tree wells
Commerce/Mixed-Use Streets	Mix of retail, residential, office, and entertainment; Medium to heavy pedestrian activity; Transit use; Streets are typically in a grid pattern; Buildings are typically multi-storied and commercial-oriented, but may have residential uses on the upper floors; Buildings front the street; On-street parking is common	Typically, much wider sidewalks. Includes all 3 of the sidewalk zones
Neighborhood Connectors	Residential, with occasional businesses; Heavy pedestrian activity; Some transit use; Run at the peripheries of residential areas, and landscaped; medians are common; Buildings or residential fences are set back from the street	Accessibility, min. width, street landscape buffer, shade (through street trees) Connect sidewalk to the front entrance of the home
Commercial Connectors	Employment, entertainment, retail, services; Medium pedestrian activity; Retail stores are generally separated from the street by surface parking lots; Sidewalks are generally buffered from the street by landscaping	Sidewalks are more functional Screening of surface parking areas through vegetative buffers Connect building entrances to sidewalk through the parking lots More informal arrangement of landscaping and sidewalks may be more naturally winding
System Links	Lower pedestrian activity; Emphasize longer-distance automobile traffic and provide connections to freeways; Few commercial buildings or residences	

Table 5-2. Minimum Pedestrian Zone Widths by Roadway Type

	Target Speed	Frontage Zone	Furnishing Zone	Sidewalk/ Pedestrian Zone	Shared-use Path or Sidepath
Local Streets	25 mph	N/A	2.5 ft min. 6 ft preferred	5 ft min. 6 ft preferred	N/A
Collectors	25 – 30 mph	N/A	4.5 ft min.	5 ft min. 6 ft preferred	10 ft required in industrial areas
Activity Streets	25 mph	7 ft min. 8 ft preferred	6.5 ft min.	5 ft min. 6 ft preferred	N/A
Commerce/Mixed-Use Streets	25 mph	8 ft	6.5 ft min.	5 ft min. 6 ft preferred	N/A
Neighborhood Connectors	30 – 35 mph	N/A	4.5 ft min.	5 ft min. 6 ft preferred	10 ft 12 ft max.
Commercial Connectors	30 – 35 mph	N/A	4.5 ft min.	5 ft min. 6 ft preferred	10 ft 12 ft max.
System Links	35 – 45 mph	N/A	4.5 ft min.	5 ft min. 6 ft preferred	10 ft 12 ft max.

 Source: [MTP](#)

5.4 SIDEWALK SPACE

Sidewalks provide pedestrians with a space to travel within the public right-of-way that is separated from motor vehicles. They are also used for social interaction, lingering, and people-watching. Narrow sidewalks hinder ADA access, lively pedestrian activity and potentially the economic activity associated with it and may create dangerous conditions where people walk in the street. Sidewalk space typically consists of three zones: the Frontage Zone, the Sidewalk/Pedestrian Zone, and the Furnishing Zone. The design of the sidewalk space is dependent on the cross section and street type as defined in the [MTP](#). The zones may vary in width and character depending on the adjacent land use, available right-of-way, and intended function. **Figure 5-1** shows a typical sidewalk zone along a Commerce/Mixed-Use Street.



Figure 5-1. Sidewalk Space

5.4.1 Frontage Zone

The Frontage Zone is the area of sidewalk that immediately abuts buildings along the street. In residential areas, the Frontage Zone may be occupied by front porches, stoops, lawns, or other landscape elements that extend from the front door to the sidewalk edge. The Frontage Zone of commercial properties may include architectural features or projections, outdoor retail displays, café seating, awnings, signage, and other intrusions into or use of the public right-of-way. This area acts as a transition between the public realm and the private realm. The [MTP](#) calls out requirements for frontage zones based on street type.

5.4.1.1 Considerations

- The Frontage Zone provides room for elements that enliven the street and create visual interest and serve functions such as sitting or window watching for pedestrians.
- The Frontage Zone announces building entrances and the occasional café.
- Where buildings are located against the back of the sidewalk and constrained situations do not provide width for the Frontage Zone, the effective width of the Sidewalk/Pedestrian Zone is reduced by 2 feet, as pedestrians will shy from the building edge.
- People with visual disabilities sometimes use the building edge for navigational purposes.

5.4.1.2 *Guidance*

- The Frontage Zone should be maximized to provide space for cafés, plazas, hanging pots and greenscape elements along building facades, but not at the expense of reducing the Sidewalk/Pedestrian Zone beyond the recommended minimum widths.
- Frontage Zones used for sidewalk cafés as shown in **Figure 5-2** are a special condition and should generally be no less than 7 feet in width.
- Refer to the [MTP](#) for Frontage Zone width ranges based on street type and other requirements.
- The development context should focus on buildings close to the front property line or sidewalk, parking in the back, and doors and windows oriented towards the sidewalk.



Figure 5-2. *Café Seating in the Frontage Zone*

5.4.2 Sidewalk/Pedestrian Zone

Sidewalk/Pedestrian Zone, also known as the “walking zone,” is the portion of the sidewalk space used for active travel. This zone has different characteristics depending on the street type as set by the [MTP](#). For it to function, it must be kept clear of any obstacles (such as street signs, light poles, trash receptacles, etc.) and be wide enough to comfortably accommodate expected pedestrian volumes including those using mobility assistance devices, pushing strollers, or pulling carts. The width of the Sidewalk/Pedestrian Zone should accommodate pedestrians passing singly, in pairs, or in small groups as anticipated by density and adjacent land use.

5.4.2.1 *Considerations*

- Sidewalks make walking an easy choice between destinations and create a network for pedestrian travel throughout the city.
- Sidewalks make access to transit possible since the majority of transit users walk between their destination and transit stops.
- When reconstructing sidewalks and relocating utilities, above ground utility access points should be relocated outside of the Sidewalk/Pedestrian Zone to the extent possible. When this is not possible, utility caps/covers should be maintained fully flush with the sidewalk (seamless), and not create a tripping hazard.

- For ease of maintenance and to communicate to pedestrians that this is space designated for their public use, pavement materials should be as uniform as possible.
- Sidewalk materials will vary, but all materials should be chosen/applied to be slip resistant in all weather conditions.

5.4.2.2 Guidance

- All new sidewalks and curb ramps must comply with [TAS](#) and [PROWAG](#) guidelines and shall be constructed according to [City standards](#).
- Refer to the [MTP](#) for minimum width requirements of Sidewalk/Pedestrian Zones that must be met based on street type.
- When decorative surfaces, such as cobblestones or brick are used, a concrete base is recommended to prevent uneven settling of surfaces. Surface treatments must not create vibrations.
- The Sidewalk/Pedestrian Zone should, as much as possible, keep to the natural path of pedestrian travel parallel to the roadway. It should be in a position that naturally aligns with crosswalks at intersections.
- It may be necessary in some locations for the Sidewalk/Pedestrian Zone to curve to form a more direct route to an intersecting walkway, to preserve significant trees, or to provide more separation between the sidewalk and the roadway. It should be noted that a curving sidewalk can increase challenges for people with visual disabilities when applied on Commerce/Mixed-Use streets. However, on more suburban streets, gentle curves within the sidewalk may help maintain existing vegetation and not be as intrusive to pedestrians with visual disabilities.
- Where sidewalks and streets intersect, changes in running grades and cross slopes may present challenges with meeting ADA requirements. As such, the 2% cross slope of the sidewalk may be difficult to maintain where an intersecting street's running slope is greater than 2%. If the intersecting street does not have yield or stop control, the cross slope of the sidewalk may increase to 5%. Where pedestrian access routes are contained within midblock pedestrian street crossings, the cross slope of the pedestrian access route shall be permitted to equal the street or highway grade. Specific requirements are set in [PROWAG](#).
- Where sidewalks intersect residential driveways and alleys, detectable warning surfaces shall not be implemented. Raised sidewalks may be used to prompt the pedestrian and driver to proceed with caution and be aware of one another.
- Detectable warning surfaces are required where sidewalks intersect driveways to commercial parking lots and structures where vehicle access is greater than 100 vehicles.
- When sidewalk is set adjacent to the curb, sidewalk must be a minimum of 6 feet.

5.4.3 Furnishing Zone

The Furnishing Zone is where most of the public amenities and utilities are located from street signs and light poles, to trees, benches, bike racks, newspaper racks, and landscaping as shown in **Figure 5-3**. It is the area between the curb and any pedestrian or bicycle facility. When included

with a clear zone, this area considers the need to set objects away from the street (to ensure they are not hit by vehicles) and the width of the objects themselves. On sections with on-street parking, this zone is minimized (2.5 feet plus the 6-inch curb) because parked cars provide the buffer to the travel way and regularly spaced bulbouts/tree wells provide opportunities for street furniture.

5.4.3.1 *Considerations*

- Green infrastructure elements should be designed to make use of stormwater runoff from the sidewalk and the street. Permeable paving may be considered.
- Sometimes private retail/restaurant seating is in this zone as well.

5.4.3.2 *Guidance*

- Refer to the [MTP](#) for minimum width requirements of Furnishing Zones.
- Utilities, street trees, and other sidewalk furnishings should be set back from the curb face a minimum of 18 inches but should be sure not to obstruct the Sidewalk/Pedestrian Zone.
- Vertical objects in the Furnishing Zone must be strategically placed to not obstruct sight lines including intersection sight triangles, to avoid damage from vehicles on the street, and to allow for access to and from parked cars and transit stops.



Figure 5-3. Benches, Street Lighting, and Trash Cans in the Furnishing Zone

5.5 LANDSCAPING IN PARKWAYS

Landscaping in parkways plays an important role in making streets comfortable, delightful, memorable, and sustainable. Used appropriately, landscaping helps define the character of a street by enhancing pedestrian comfort and separating pedestrians from motor vehicle traffic. Parkway also create a perceived narrowing of the street and are an important tool to help bring down speeds. The use of different materials can reinforce neighborhood identity and history through their selection, arrangement, coloring, or patterns. The selection of these materials should be context-sensitive to the surrounding environment. This section discusses landscaping in the context of the pedestrian experience; however, many of these elements may also serve as

valuable stormwater management infrastructure. Stormwater management design guidelines are discussed in **Chapter 10** of this manual.

5.5.1 Street Trees and Plantings

5.5.1.1 Considerations

- Street trees improve walkability by providing necessary shade and filtered light.
- As vertical elements in the streetscape, trees help to frame and define the street wall, accentuate spaces and focus view corridors.
- Canopy trees provide an enclosure to the street that reinforces the sense of intimacy and scale. Motorists respond to this enclosure, often reducing their speed.
- Street tree enclosure can have positive effects in slowing traffic and increasing driver attentiveness and awareness of their surroundings.
- Street trees and plantings can be installed in different zones of the parkway to accommodate adjacent land use and activities and anticipated pedestrian circulation.
- Planting in the public right-of-way typically occurs in the Furnishing Zone and medians; however, this is not the only place that can accommodate planting. Wherever there is an opportunity for landscape features, street, or development projects should also look for opportunities to incorporate plantings.
- Landscaped areas in the Frontage Zone can be excellent places to plant trees as they offer open areas for roots to spread. This is particularly the case when the Frontage Zone consists of (or is adjacent to) lawn panels or other open spaces.
- Plantings are still possible in the Frontage Zone adjacent to building foundations; however, to avoid any intrusive roots, barrier material is recommended.
- The [MTP](#) allows in-street trees to be placed in bulbouts between parking areas.

5.5.1.2 Guidance

- A medium or large tree shall be planted a minimum of 2 feet from the face of the curb, sidewalk, or other structure.
- A small tree or shrub shall be planted a minimum of 1.5 feet from the face of the curb, sidewalk, or other structure.
- A minimum planting area of 3 feet must be available between back of curb and sidewalk to plant any small tree or large shrub and a minimum of 4 feet to plant large trees. A large tree shall be defined as a species that reach a height of 50 feet at maturity.
- In residential areas a minimum spacing of twenty-five feet is recommended between shade trees planted on parkways and is required in commercial districts or major arterial streets.

5.5.2 Tree Wells

5.5.2.1 Considerations

- These systems are installed in a series with drains connecting the series.

- Tree grates, or permeable metal structures surrounding a tree base, allow water to enter the root system. Silva cells take this one step further by simultaneously supporting large tree growth and an underground infiltration system.
- In densely urban areas or those with limited sidewalk width, ADA-compliant tree grates may be necessary.
- At street level, they appear to be individual features with sidewalk segments separating each well.
- Consider installation on Activity Streets and Mixed-Use Streets.
- Consider rectangular (rather than square) tree wells, as they maximize the width of pedestrian zones.

5.5.2.2 Guidance

- A 6-foot minimum Pedestrian Zone should be left adjacent to a tree well
- A typical tree well width is 6 feet.
- Allow 15 feet of space between tree wells.

Figure 5-4 shows tree wells in the Furnishing Zone.

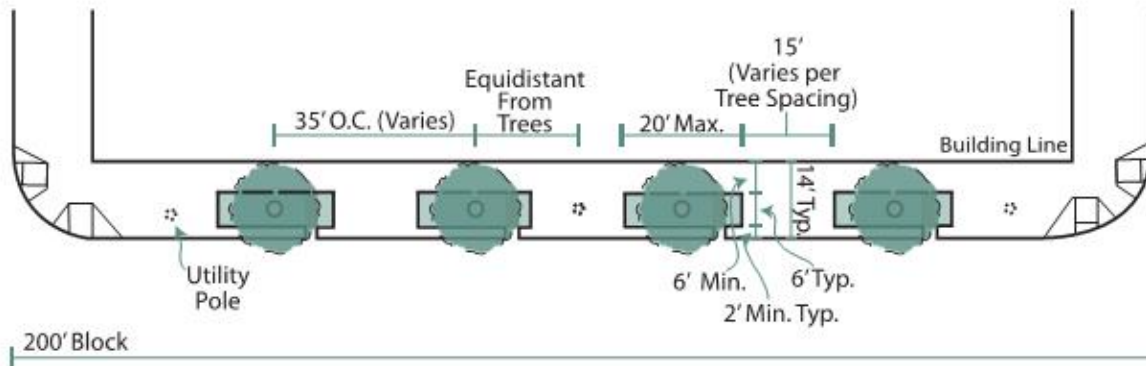

Figure 5-4. Tree Wells in the Furnishing Zone

5.5.3 Continuous Planting Strip

5.5.3.1 Considerations

- These systems are installed in a series with drains connecting the series.
- At the street level, they appear to be a continuous feature with a large area of visible landscape planting and are occasionally separated by sections of sidewalk.
- They can be installed in the Furnishing Zone or mid-way between the curb and the building face on Mixed-Use Streets, Commercial Connectors, Neighborhood Connectors, and Industrial Streets.
- They can be installed in the Frontage Zone on Local Streets and some Neighborhood Connectors.

5.5.3.2 Guidance

- A 6-foot minimum pedestrian zone should be left adjacent to the landscaping feature in areas with greater pedestrian volumes.
- On local streets, a 5-foot minimum pedestrian zone should be left adjacent to the landscaping feature.
- Landscaping features should be placed to avoid intersection sight triangles as set forth in **Chapter 6** of this manual. Caution should be applied when locating legs of visibility area.
- The typical planting strip width is 6 feet.
- Allow a 12-foot minimum of space between utility poles and tree centers.

Figure 5-5 shows the placement of continuous planting strips in different zones.

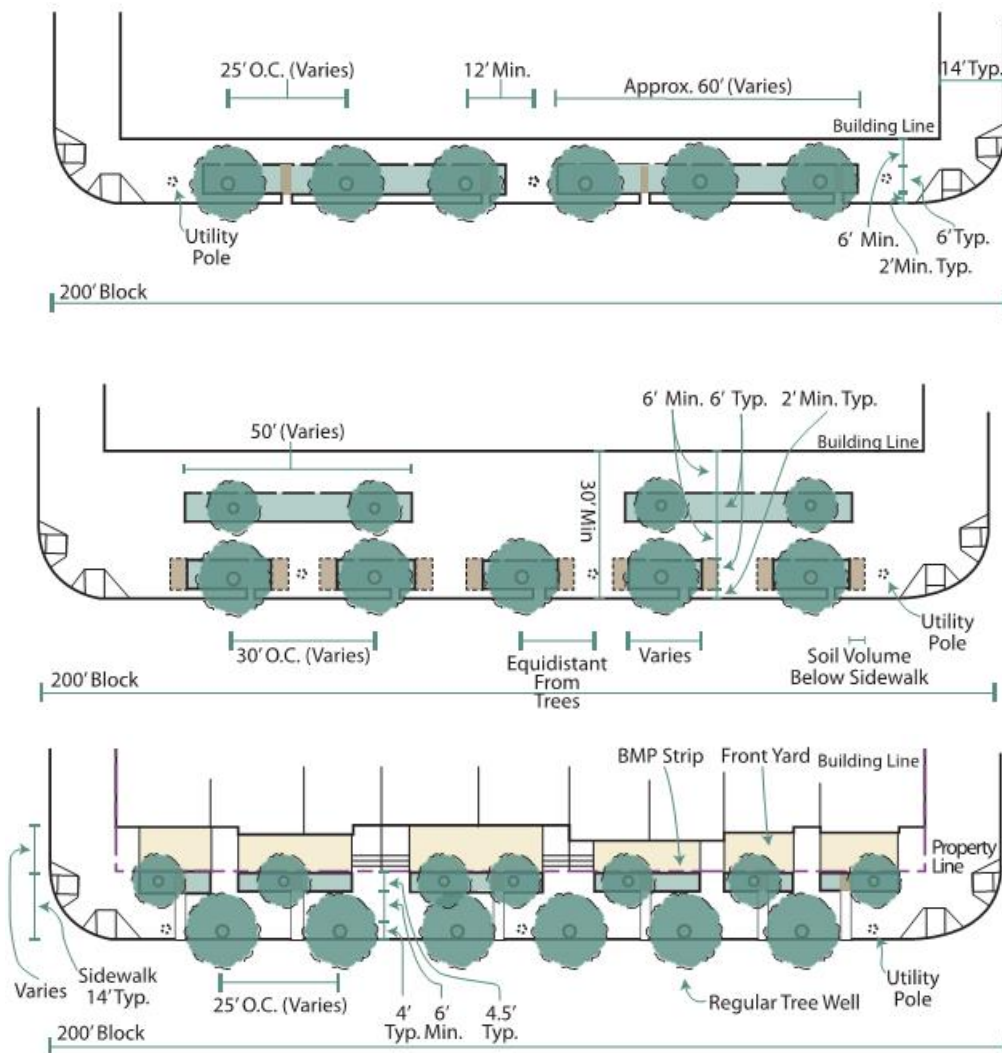

Figure 5-5. Continuous Planting Strips in the Furnishing Zone, Mid-Way, and Frontage Zone Positions

5.6 CURB RAMPS

Curb ramps facilitate pedestrian access between sidewalks and street crossings, and between sidewalks and accessible on-street parking. The designs of curb ramps are critical for all people, but particularly for people with disabilities. Curb ramps also benefit people pushing strollers, grocery carts, suitcases, or bicycles. **TAS** guidelines require all pedestrian crossings be accessible to people with disabilities by providing curb ramps at intersections (as shown in **Figure 5-6**) and mid-block crossings as well as other locations where pedestrians can be expected to enter the street. The curb ramp at the intersection must be provided in accordance with City's standards and in compliance with **TAS** and **PROWAG**.

Separate curb ramps should be provided for each crosswalk at an intersection rather than a single ramp at a corner for both crosswalks. The separate curb ramps improve orientation for people with visual disabilities by directing them toward the correct crosswalk.

5.6.1.1 Considerations

- Where feasible, curb ramp locations should reflect a pedestrian's desired path of travel through an intersection. In general, this means providing two separate perpendicular curb ramps at a corner instead of a single ramp that opens diagonally at the intersection.
- Each curb ramp must include a landing/turning space for wheelchair maneuverability and a detectable warning surface to alert pedestrians with a visual disability that they are entering or exiting the roadway. Landings shall be designed in accordance with **PROWAG**.
- Detectable warning surfaces should be placed at the back of the curb, unless otherwise specified by **PROWAG**.
- Detectable warning surfaces are especially needed at blended transitions (i.e., crossings with a running slope less than 5 percent) raised crossings, and at pedestrian crossing islands. It is under these conditions where visually challenged pedestrians find it difficult to detect a change.
- ADA regulations require that ramps be a minimum of 4-feet wide; however, in areas of high pedestrian volumes and crossing activities, wider curb ramps should be considered. Ideally, the width of the curb ramp should match the width of the sidewalk.
- For high-volume pedestrian crossings it is best for ramps to be the full width of the crossing width.
- **PROWAG** allows for different maximum cross slopes depending on the traffic control in place at the crossing.
- Flares are required when the surface adjacent to the ramp's sides is walkable, however, they are unnecessary when this space is occupied by a landscaped buffer. **Figure 5-7** shows an example of a flared and non-flared curb ramp. Excluding flares can also increase the overall capacity of a ramp in high-pedestrian areas.

5.6.1.2 Guidance

- Running and cross slopes and landing areas shall comply with **TAS** and **PROWAG** requirements.

- Curb ramps shall direct pedestrians into the crosswalk. The bottom of the ramp must lie within the area of the crosswalk.
- Truncated domes (the only permitted detectable warning device) must be installed on all new curb ramps to alert pedestrians to the sidewalk and street edge.
- Ramps which provide one ramp leading to each crosswalk at an intersection are strongly preferred over ramps that provide only a single ramp for multiple crosswalks.
- Under no circumstances shall a curb ramp be installed allowing a pedestrian to enter a crossing without providing a curb ramp (or at grade sidewalk if no curb is present) on the opposite side of the crossing.



Figure 5-6. Example Intersection with Curb Ramps at All Approaches

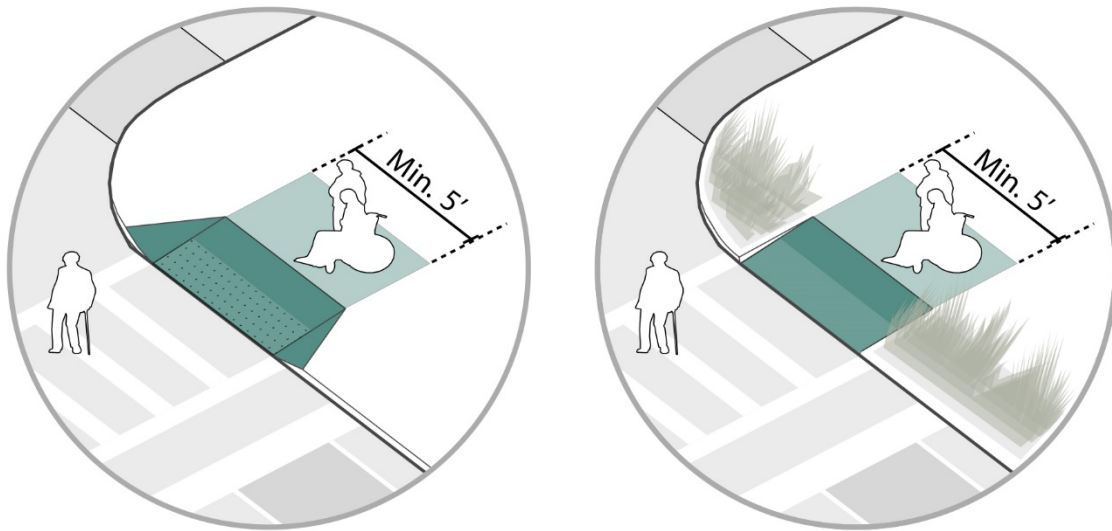

Figure 5-7. Flared Curb Ramp (left) and Non-Flared Curb Ramp (right)

5.7 UTILITIES

5.7.1.1 Overview

Effective management of utility placement on, above, and below the sidewalk area ensures a safer and more enjoyable street environment. The placement of other sidewalk amenities can potentially reduce maintenance access to utilities, highlighting the need for interdepartmental coordination. Utilities that affect sidewalk functionality include surface-mounted facilities such as utility vault and signal boxes, above-ground infrastructure such as power and telecommunications wiring, and underground infrastructure serving electricity, storm drainage, sewer and water, gas, telecommunications, street lighting, and traffic signalization.

Well-placed utilities and other infrastructure reduces clutter on the sidewalk, improves pedestrian safety, reduces maintenance conflicts with other street amenities, and allows for more landscaping and trees. The following is from [The City of Los Angeles Complete Streets Design Guide](#).

5.7.1.2 Considerations

- Tree removal should be avoided and minimized during the routing of large-scale utility undergrounding projects.
- Many projects involving sidewalk widening or curb extensions require the demolition or excavation of an existing walkway, and existing underground utilities may be impacted. Utility companies should be contacted and provided with plans outlining the proposed improvements.
- When adding curb extensions or widening the sidewalk, utilities such as water mains, meters, and sewer vents should remain in place whenever possible, as they can be cost prohibitive to

move. Utility vaults and valves should be minimized in curb extensions where planting or street furnishings are planned.

- Utility installation and repair should be coordinated with roadway and streetscape improvement projects to avoid duplication of efforts or making new cuts in new pavement. Roadway and streetscape improvement projects provide the opportunity to incorporate utility retrofits and new utility installations.
- In densely-developed districts, utility vaults and valves may be placed in the Frontage Zone. To facilitate access, however, the placement of utility structures in the Frontage Zone is preferred only when it has been determined that incorporating utility vaults into the Furnishing Zone is not feasible.
- Some of the most extensive visual and physical intrusions into the built environment are utility poles and overhead lines for power and communications. These can interfere with the placement of amenities such as street trees/landscaping, seating, street lighting, and stormwater management. The relocation of overhead utility lines can provide an aesthetic benefit and allow for better sidewalk accessibility, growth of trees and increased opportunities for sidewalk enhancements and amenities. Removing overhead utility lines by undergrounding them or relocating them to alleys or rear yards can create opportunities to implement Complete Streets features.
- Above-ground electrical lines are typically not insulated and therefore necessitate the regular pruning of street trees and may prevent the planting of new trees that are appropriately scaled for the street. As a result, the myriad benefits of street trees, aesthetic, cooling effect, air quality, etc., are often compromised. An alternative, where the lines cannot be undergrounded or relocated, may be to replace the existing electrical lines with insulated, braided lines used in back yard conditions. Tree branches can grow around these electrical lines without concern that a fire will started if the lines break. Trees will still need to be pruned when limbs put pressure on power lines.

5.7.1.3 *Guidance*

- Where practicable, the placement or relocation of new utilities should avoid areas conducive to future placement of street amenities such as seating areas, landscaping, stormwater management treatments, and transit stops. New development should submit utility plans with initial development proposals so that utilities can be placed away from suitable locations for streetscape amenities where practicable. Conversely, the placement of street amenities (e.g., street furniture and landscaping) must ensure easy access to utilities for maintenance and emergencies.
- Existing vaults located in a curb ramp should be moved or modified to meet accessibility requirements.
- Small utility vaults, such as water and gas meters and street lighting access, should be located to minimize conflicts with existing or potential tree locations and landscaped areas. Vaults should be aligned or clustered wherever possible.
- Above-grade and surface-mounted utilities should be placed to minimize disruption to pedestrian travel, and to maintain required widths for pedestrian access routes.

- Inlets and surface flow lines associated with storm drainage systems should be located away from the crosswalk or between curb ramps. Inlets should be located upstream of curb ramps to prevent ponding at the bottom of the ramp.
- In pedestrian-oriented residential and commercial areas, surface-mounted utilities should be screened with landscaping and/or decorative screens whenever practicable.
- Trenchless technologies, such as moling and tunneling, should be used where possible to avoid excavation and disruption of streetscape elements.

5.8 STREET FURNISHINGS

Streetscape furnishings help create a consistent and inviting setting. Elements such as benches, tables, chairs, refuse receptacles, plantings, and bicycle parking create a space where visitors and potential customers can congregate. Pavers and pedestrian level streetlighting also adds to the ambience of the streetscape. Streetscape furnishings should relate to the street type.

5.8.1 Transit Stops

Guidance on transit stops can be found in **Chapter 9** of this manual.

5.8.2 Bike Parking

Without bicycle parking, bicycle networks are of limited use. Bicycle parking enables bicyclists to safely leave their bicycles and enjoy the offerings of the street or to patronize businesses and destinations in the city. Bicycles take up substantially less space than automobiles, in fact, 10-12 bicycles can typically park in the area needed for a single car. Therefore, by providing bicycle parking, the City can ensure access for many while using a relatively small area of the right-of-way.

The most common means of providing bicycle parking is with bicycle racks and bicycle corrals. Bike share stations are a unique form of bicycle parking utilized only by bicycles associated with that system. More information on bike parking can be found in **Chapter 4** of this manual.

5.8.3 Seating

5.8.3.1 Overview

Public seating enhances the usability and enjoyment of the street and can be provided in several different ways. It can be integrated into other street elements such as the edge of planters and steps or as protection around trees. Seating may be fixed or mobile and adaptable. It may be made of any number of materials; however, durability and maintenance are key considerations.

5.8.3.2 Considerations

- Seating should be provided both with and without armrests, if possible. Armrests provide stability for those who require assistance sitting and standing. Seating without armrests allows a person in a wheelchair to maneuver adjacent to seating or to slide onto it easily.
- Movable seating is generally provided by and/or through a private owner who will store seating at night and monitor its use to ensure it is not placed in any travel way.

- Seating should be located where it is most attractive and useful and not obstruct Sidewalk/Pedestrian Zones. Seating that serves a particular need, waiting for transit or resting from shopping, are always welcome.
- Seating is comfortable when it is in an area that has adequate observation to and from street life and sufficient lighting to feel safe.

5.8.3.3 *Guidance*

- Clear distances from other elements:
 - 3 feet minimum on either side of the bench (except beside an ad panel of a bus shelter, where a 6-foot clear width is required to open the panel door).
 - 5 feet minimum from fire hydrants, > 1 foot minimum from any other amenity, utility, or fixture.
 - 5 feet minimum, ideally 6 feet clear path to provide an additional 1 foot for people’s legs, in front of the bench when located at the back of the sidewalk, facing the curb.
 - Where the back of the bench abuts a building, wall or other obstruction, a 1-foot minimum clear width should be provided for maintenance and trash removal.
- Seating in the Furnishing Zone should be located at least 2 feet from the face of curb to reduce conflict with other curbside uses. It should be at least 10 feet away from fire hydrants and have at least 36 inches of clear space between it and trash receptacles or other fixed objects.
- Seating in the Furnishing Zone should be located at least 2 feet from the face of curb to reduce conflict with other curbside uses. It should be at least 10 feet away from fire hydrants and have at least 36 inches of clear space between it and trash receptacles or other fixed objects.
- 5-foot minimum clear path must be provided behind a bench when located at the front of the sidewalk facing the curb.
- Seating should be designed with a bench seat height of 17 inches minimum and 19 inches maximum above the ground.
- Seating is most commonly located in the Furnishing Zone of the street but may also be placed in the Frontage Zone. Seating in the Furnishing Zone should generally face away from the street and toward the sidewalk or be aligned perpendicular to the curb. Seating in the Frontage Zone should face the street.
- Seating should be visible, but not obtrusive. It should remain out of the primary paths of travel and not conflict with entrances to buildings, loading zones, parked vehicles, access to fire hydrants or other similar activities.
- Seating may be in areas with or without shade. Shaded seating is appreciated in the hot summer months, while seating in sunlight is desirable on colder days.
- Seating should be provided for a minimum of two people. Single seats may be provided as long as they are in groups of two or more.
- In commercial districts, seating, at a minimum, should be considered on both sides of the street on all blocks.

- Seating should be made of materials that dry quickly or have porous (wire mesh) or other methods to maximize drying.
- When possible, avoid black or other colors that build and retain heat.

5.8.4 Dumpster Location

A minimum of 16 feet must be provided between the dumpster and travel lane so that dumpster servicing does not block travel lanes. The dumpster servicing zone may cross sidewalks, parkways, on-street parking zones and slip lanes. Exceptions can be provided on a case by case basis and require administrative approval.

5.9 STREET LIGHTING

Street lights should not impede the pedestrian travel path. Adequate lighting at intersections and crosswalks improve pedestrian safety at these locations. Lighting is typically located in the Furnishing Zone of the street. All street lighting installations should follow the guidelines outlined in the Street Lighting section in **Chapter 3** of this manual.

Contents

CHAPTER 6 - INTERSECTION DESIGN	6-3
6.1 Introduction	6-3
6.2 Intersection Type Selection	6-3
6.3 Basic Intersection Forms	6-3
6.4 Intersection Functional Area	6-4
6.5 Design Objectives	6-5
6.6 Design Principles.....	6-5
6.7 Design Guidelines	6-6
6.7.1 Design Vehicles	6-6
6.7.1.1 Design Criteria	6-7
6.7.1.2 Guidance	6-9
6.7.2 Alignment and Profile	6-9
6.7.3 Intersection Sight Distance.....	6-9
6.7.4 Curb Radii	6-11
6.7.5 Channelization	6-13
6.7.6 Auxiliary lanes	6-14
6.7.6.1 Deceleration Length.....	6-15
6.7.6.2 Storage Length	6-15
6.7.6.3 Taper Length	6-16
6.7.6.4 Left-Turn Channelization.....	6-16
6.7.7 Curb Extensions (Bulbouts).....	6-17
6.7.8 Controlled Crosswalks.....	6-18
6.7.9 Curb Ramp Placement.....	6-18
6.7.10 Median End Treatment.....	6-18
6.8 Other Intersection Designs	6-19
6.8.1 Roundabouts.....	6-19
6.8.2 Skewed Intersection.....	6-19
6.8.3 Multi-Leg Intersection	6-20
6.9 Intersection Control	6-21
6.9.1 Uncontrolled Intersection.....	6-21
6.9.2 Yield Controlled Intersection	6-21
6.9.3 Stop-Controlled Intersection	6-22
6.9.4 Signalized Intersection	6-22
6.9.4.1 Traffic Control Signal and Pedestrian Signal Installation Policy..	6-23

List of Figures

Figure 6-1. Common Intersection Types	6-4
Figure 6-2. Intersection Physical Area.....	6-4
Figure 6-3. Intersection Functional Area.....	6-5
Figure 6-4. Typical Design Vehicle Dimensions	6-8
Figure 6-5. Intersection Sight Triangles.....	6-11

Figure 6-6. Curb Radius Design Types 6-12
 Figure 6-7. Types of Islands..... 6-14
 Figure 6-8. Auxiliary Turn Lane Components 6-15
 Figure 6-9. Left-Turn Lane Offsets 6-16
 Figure 6-10. Curb Extension Applications 6-18
 Figure 6-11. Intersection Realignment Options (AASHTO Green Book (2018))..... 6-20
 Figure 6-12. Realigning Multi-Leg Intersections (AASHTO Green Book (2018))..... 6-21

List of Tables

Table 6-1. Recommended Design Vehicle Based on Street Type 6-7
 Table 6-2. Intersection Sight Distance..... 6-11
 Table 6-3. Minimum Curb Radii..... 6-13

CHAPTER 6 - INTERSECTION DESIGN

6.1 INTRODUCTION

An intersection is defined as the area within the roadway segment where two or more roadways join or cross. There are two types of intersections: at-grade intersections and grade separated intersections. This chapter primarily focus on at-grade intersections. Intersections generally have more conflict points than other parts of street and frequently experience operational and safety issues. Hence, the successful operations of streets largely depend upon the design of intersections along street segments. Intersections should accommodate all types and sizes of anticipated movements of various road users safely and efficiently, including motorized vehicles and all ages and abilities of bicycle and pedestrians. Bicycle and pedestrian traffic in urban areas is an integral component of an intersection and must be accommodated. This chapter provides information to design an intersection and its relevant features for the effective movement of each intersection user.

6.2 INTERSECTION TYPE SELECTION

The feasibility of a roundabout intersection or other non-standard intersection versus a traditional signalized or stop-controlled intersection must be first evaluated with a City approved intersection control evaluation tool during the preliminary planning process. The preliminary planning process shall also include a pre-design meeting. The selection of intersection type is largely based on the following factors:

- Design vehicle.
- Total traffic volumes including design hourly volumes, traffic composition, and turning volumes.
- Target speed.
- Intersection profiles and grades.
- Overall network and block dimensions.
- Adjacent land uses and desired intersection operations.
- Potential to reduce the severity of conflicts.
- Optimize function for all users including vehicles, pedestrians, and bicyclists.

6.3 BASIC INTERSECTION FORMS

There are four basic forms of intersections, which are three-leg (T or Y), four-leg, multi-leg, and roundabouts. Each of these types of intersections can be further categorized into different variations such as channelized, flared, or unchannelized. Intersecting streets ideally intersect at 90-degree angles, but at times more complex entries are encountered. Roundabouts can be

further classified into mini-roundabouts, single lane roundabouts, and multi-lane roundabouts. **Figure 6-1** shows various types of these different forms of intersections.

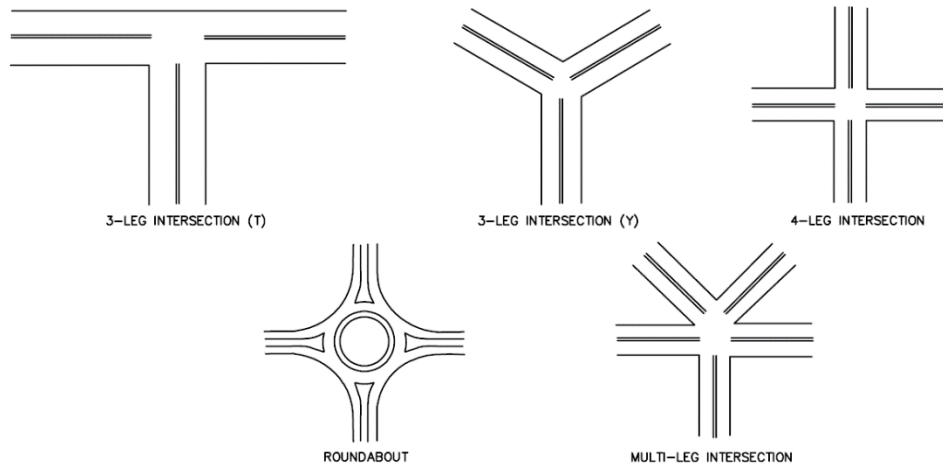

Figure 6-1. Common Intersection Types

6.4 INTERSECTION FUNCTIONAL AREA

An intersection area is defined as two distinct types of area in the AASHTO Green Book: Intersection Physical Area (**Figure 6-2**) and Intersection Functional Area (**Figure 6-3**). The physical area of an intersection is generally the area between curb returns of intersecting streets whereas the functional area of intersection is defined by the elements like perception-reaction decision distance for the intersection movements, maneuver distance and the queue storage distance. In other words, the functional area of an intersection is the area of intersection and its approaches where the effect of intersection exists. Intersection design should accommodate the design of both of this physical and functional area of an intersection.

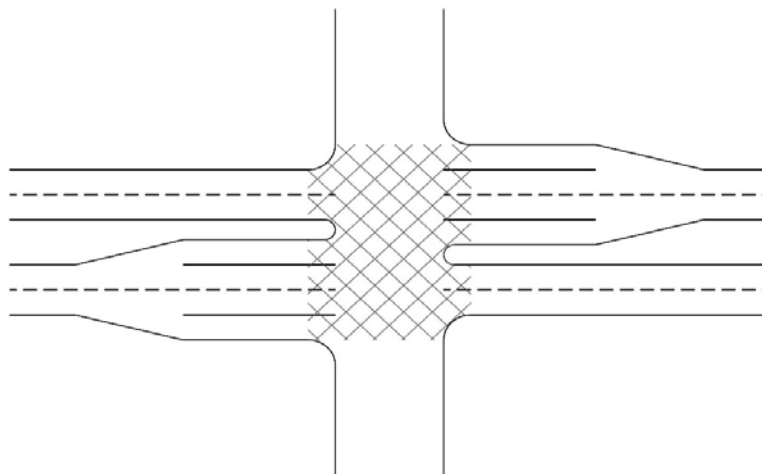

Figure 6-2. Intersection Physical Area

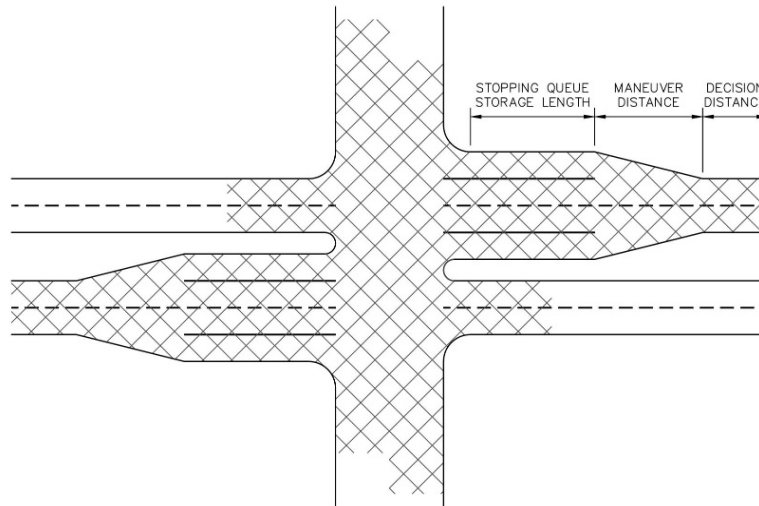

Figure 6-3. Intersection Functional Area

6.5 DESIGN OBJECTIVES

The main objective of intersection design is to create safe and efficient movements for all anticipated travel modes at an intersection including passenger cars, buses, trucks, transit, bicycles, pedestrians, and people with special needs. Intersections should be designed to be intuitive and to reduce crashes and crash severity while facilitating ease and comfort for the road users making the necessary movements. The intersection should provide sufficient capacity to accommodate all users.

The design and layout of intersections should focus on the following parameters for safe and efficient operations:

- Adjacent land uses which are generally travel destinations.
- Overall grid network layout.
- Pedestrian crossings as well as turning movements of vehicles and bicycles.
- Intersection operations such as stop and yield signs, traffic signals, roundabouts, and other forms of traffic control.
- Capacity for the implemented traffic control, as intersection capacity is largely dependent on the implemented traffic control.

6.6 DESIGN PRINCIPLES

Traditionally, considerations were primarily given to motor vehicles while not providing adequate accommodations for other intersection users. Intersection design should accommodate all types

on intersection users that are expected to use the intersection. The intersection design should minimize conflict points and the speed of conflicts between all road users including motor vehicles, transit, bicycles and pedestrians.

In addition to minimizing conflict points, intersections should be designed to provide proper visibility, turning paths, channelization, and traffic control. Intersections should also provide well-marked crosswalks, sidewalks, and curb ramps to comply with [TAS](#) and [PROWAG](#). Bicycle accommodation for passing and crossing through intersections should be provided where bikes are expected.

6.7 DESIGN GUIDELINES

The geometric design of an intersection directly influences the safety, convenience, and operational efficiency of an intersection. The basic intersection design elements are discussed in this section. Detailed information on accommodating and designing for bicyclists at intersections can be found in **Chapter 4** of this manual. In general, the design of intersections shall consider the following factors:

- Thru lanes shall align across intersections without offset.
- The design shall align with the natural paths and operating characteristics of drivers and vehicles.
- Changes in direction shall be accommodated by smooth transitions.
- Grades shall be relatively flat.
- The design shall provide sufficient sight distance to aid drivers in case of potential conflicts.
- Design shall consider and accommodate for all existing and future pedestrian volumes and movements.

6.7.1 Design Vehicles

The design vehicle governs several geometric features in street design from lane widths to curb radii. Choosing the appropriate design vehicle is critical for a safe and cost-efficient design. The design vehicle should be consistent with the street type. Designing for a vehicle larger than necessary may cause increased cost for the project. This may sometimes cause unsafe conditions for bicyclists and pedestrians while accommodating occasional larger vehicles due to increased crossing distances. The turns of vehicles larger than the design vehicle may be considered if there are some infrequent use by such vehicle. However, on those instances, encroachment onto opposing traffic lanes or sides of streets, as well as multiple-point turns may be permitted if it can be done safely. Designing for a vehicle smaller than required may make the street inaccessible to most of the vehicles passing through it and cause other operational problems. Hence, it is important to consider the frequency of vehicle types passing through a location when determining the design vehicle.

The design vehicle should be able to make all movements on the street and intersection without encroaching onto opposing traffic lanes.

At the very minimum, emergency vehicles need to be used as a design vehicle for street design. Emergency vehicles need to have enough space to pass through the intersection and make turns. Other vehicles are required to give way to emergency vehicles. Therefore, transportation networks should, at minimum, accommodate for emergency vehicles given that those vehicles can use the entire traveled way.

6.7.1.1 *Design Criteria*

Table 6-1 includes recommendations on the appropriate design vehicle based on street type. **Figure 6-4** shows the design vehicle dimensions.

Table 6-1. Recommended Design Vehicle Based on Street Type

Street Type	Recommended Design Vehicle
System Link	WB-67
Commercial Collector	WB-62
Neighborhood Connector	WB-62
Commerce/Mixed-Use Street	BUS-40*/Emergency Vehicle**
Activity Street	BUS-40*/Emergency Vehicle**
Standard Collectors	BUS-40*/Emergency Vehicle**
Industrial Collectors	BUS-40*/Emergency Vehicle**
Local Street	BUS-40*/Emergency Vehicle**
Limited Locals	BUS-40*/Emergency Vehicle**
Alleys	BUS-40*/Emergency Vehicle**

* = If transit is expected to travel on the street, a city transit bus should also be accommodated for in the design.

** =The design of emergency vehicles shall be obtained from the City Fire Department.

WB-67 (INTERSTATE SEMITRAILER)

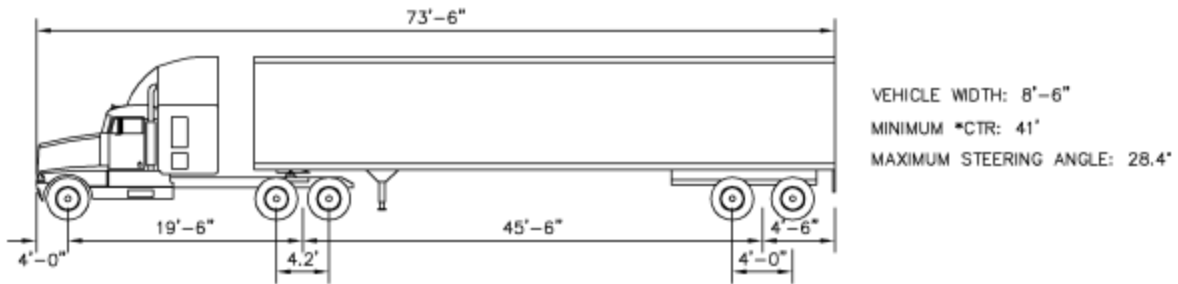

WB-62 (INTERSTATE SEMITRAILER)

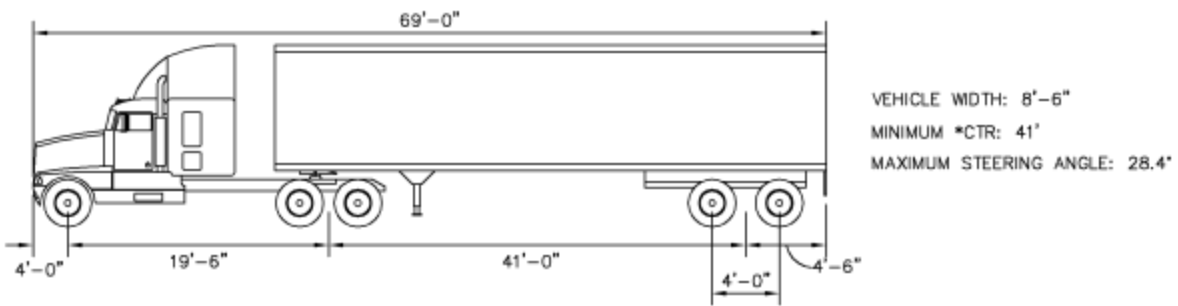

BUS-40 (INTERCITY BUS)

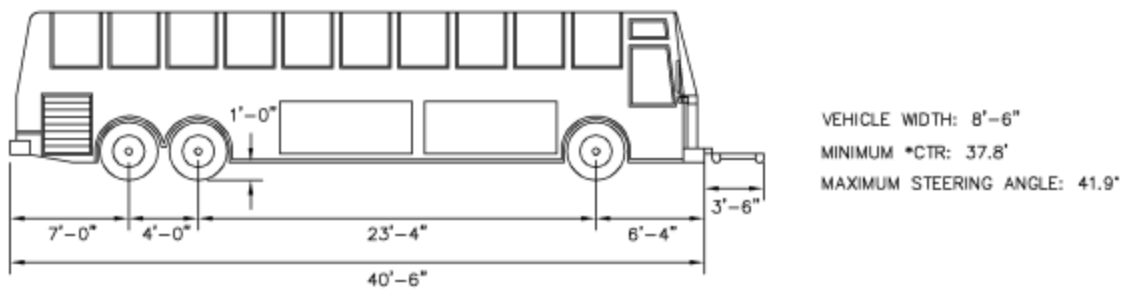

Figure 6-4. Typical Design Vehicle Dimensions

6.7.1.2 *Guidance*

The [MTP](#) accommodates emergency vehicle access through both the network and streets through its design considerations. The City's [Access Management Policy](#) states that providing for U-turns sometimes includes widening improvements to medians and/or streets to ensure that the design vehicle can make the U-turn.

It is desirable to estimate the frequency and type of vehicles for a street when assigning the design vehicle. Future estimates of the variety of traffic types should be consistent with the [MTP](#). If there are no expectations, national guidelines should be followed.

The latest edition of the AASHTO Green Book provides four classes of design vehicles: passenger cars, buses, trucks, and recreational vehicles. Dimensions for 20 design vehicles that fall into these categories are also provided. It is recommended to choose the largest design vehicle that uses the facility with considerable frequency or a design vehicle with special characteristics appropriate to a location.

6.7.2 **Alignment and Profile**

The alignment of an intersection has significant effect in reducing cost and crash frequency. Consideration should be given to provide intersecting roadways to meet at or nearly at right angles. Excessive angles for the intersecting roadways increases the exposure time for the crossing vehicles or pedestrians, which can result in capacity and safety problems at the intersection.

The intersecting and combining grade lines that must take place in an intersection area can be challenging in the intersection profile design. Consideration should be given to avoid substantial grade changes and combination of grade lines. The intersection should be designed to provide adequate sight distance along intersecting roadways and across their corners even where one or both roadways are on a vertical curve. The profile grade lines at intersection approaches should be designed to provide proper drainage.

The alignment and the profile of an intersection shall be designed in accordance with the latest edition of the AASHTO Green Book.

6.7.3 **Intersection Sight Distance**

Sight distance is the key in minimizing potential conflicts at the intersection. Adequate sight distance should be provided along all legs of intersection corners. This helps drivers approaching an intersection have an unobstructed view of the entire intersection that is sufficient to allow drivers to perceive potential conflicts and respond appropriately. Having sufficient intersection sight distance also allows for drivers of stopped vehicles to make decisions about when to turn onto or cross the intersecting roadway.

Stopping sight distance is continuously provided along all roadways for drivers to view sufficient section of roadways ahead in case stopping is required. However, in the case of the intersection area, in addition to stopping sight distance, adequate intersection sight distance should be provided for the crossing and turning movements. Intersection sight distance is provided through various sight triangles defined in the latest edition of the AASHTO Green Book. Clear sight triangles are areas along legs and across corners of an intersection that are clear of any obstructions that could block a driver's view of the intersection.

Each corner of an intersection should include a sight triangle. Approach sight triangles are used to allow approaching drivers an unobstructed view of conflicting vehicles. The length of the legs of the approach sight triangle along the roadways should be long enough so that drivers have enough time to stop or slow down before colliding within the intersection. Departure sight triangles provide sufficient sight distance to drivers of stopped vehicles to make decisions on when to cross or turn onto the roadway.

An object's height and position, the vertical and horizontal alignment of the roadways, and the driver's eye height above the roadway (3.5 feet is standard) should be taken into consideration when determining whether an object is a sight obstruction.

The AASHTO Green Book defines intersection sight distance for corner visibility for the following traffic control options:

- Case A – Intersection with no control
- Case B – Intersection with stop control on minor road
 - Case B1 – Left turn from minor Road
 - Case B2 – Right turn from minor Road
 - Case B3 – Crossing maneuver from minor road
- Case C – Intersection with yield control on minor road
 - Case C1 – Crossing maneuver from minor road
 - Case C2 – Left turn from the minor road
- Case D – Intersection with Traffic Signal control
- Case E – Intersection with all-way stop control
- Case F – Left turn from major road
- Case G – Roundabout

The required intersection sight distance for each of these scenarios varies. Based on the type of movements and intersection controls, the design shall provide the required intersection sight distance outlined in the latest edition of the AASHTO Green Book. Intersection sight distance for cases B1 and B2 are provided in **Table 6-2**. **Figure 6-5** shows the near side and far side departure sight triangles at an intersection.

Refer to AASTHO Green Book for the intersection sight distance needed for other scenarios.

Table 6-2. Intersection Sight Distance

Target Speed (mph)	Sight distance by Number of Lanes in Cross Section Near and Far Side (feet)*									
	2		3		4		5		6	
	Near	Far	Near	Far	Near	Far	Near	Far	Near	Far
25	240	280	240	295	240	295	240	315	-	-
35	335	390	-	-	335	415	335	440	335	440
40	-	-	-	-	385	475	385	500	385	500

*Note: Intersection sight distances shown are for a stopped passenger car at grades 3% or less and based on the City's typical cross sections. For other conditions, refer to the latest edition of the AASHTO Green Book.

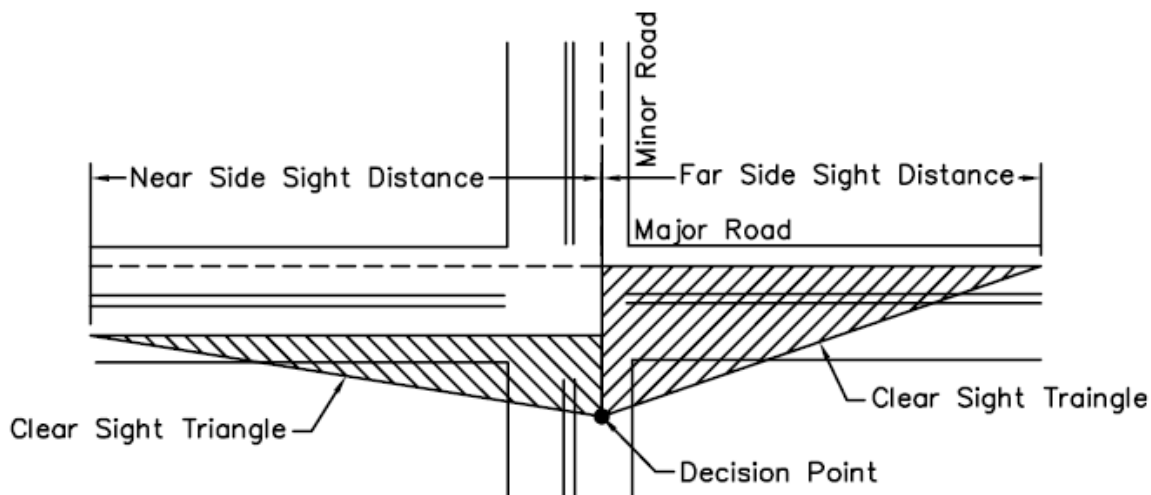

Figure 6-5. Intersection Sight Triangles

6.7.4 Curb Radii

Curb radii have a direct impact on the speed of turning vehicles and intersection operations. The curb radii of an intersection depend on the design vehicle, pedestrian and bicycle usage, the geometry, lane configuration, and operational characteristics of the roadway according to the AASHTO Green Book. Larger curb radii are necessary on System Links and Commercial Connectors as larger vehicles are expected to use these facilities. However, on lower speed urban streets with more pedestrian activity (lower speed Neighborhood Connectors, Activity and Commerce/Mixed-Use streets, collectors, and local streets), smaller curb radii are preferred to encourage lower turning speeds and shorten pedestrian crossing distances. Smaller curb radii also allow for better alignment of curb ramps. The curb radius may be designed with a simple or compound curve as shown in **Figure 6-6**. The corner radius can be different from the effective turning radius. The corner radius depends on the intersection geometry while the effective turning radius is the radius of the path vehicles take when turning onto the intersecting street. If the corner radius is not designed properly, drivers may be encouraged to take wide turns and maneuver into the opposing lane of traffic.

In the design of the curb radii based on the turning path of the design vehicle, it is assumed that the design vehicle is positioned 2 feet from the edge of the tangents of the traveled way when starting and completing a turn. The edge of travel way is designed to have at least a 2-foot clearance with the inner wheel path of the design vehicle throughout most of the turn. Differences in the turning paths of left- and right-turn maneuvers are considered negligible and not significant enough to mandate separate edge of traveled way designs. If designing for turning vehicles in a limited space, the corner radii should be based on the minimum turning radius of the design vehicles.

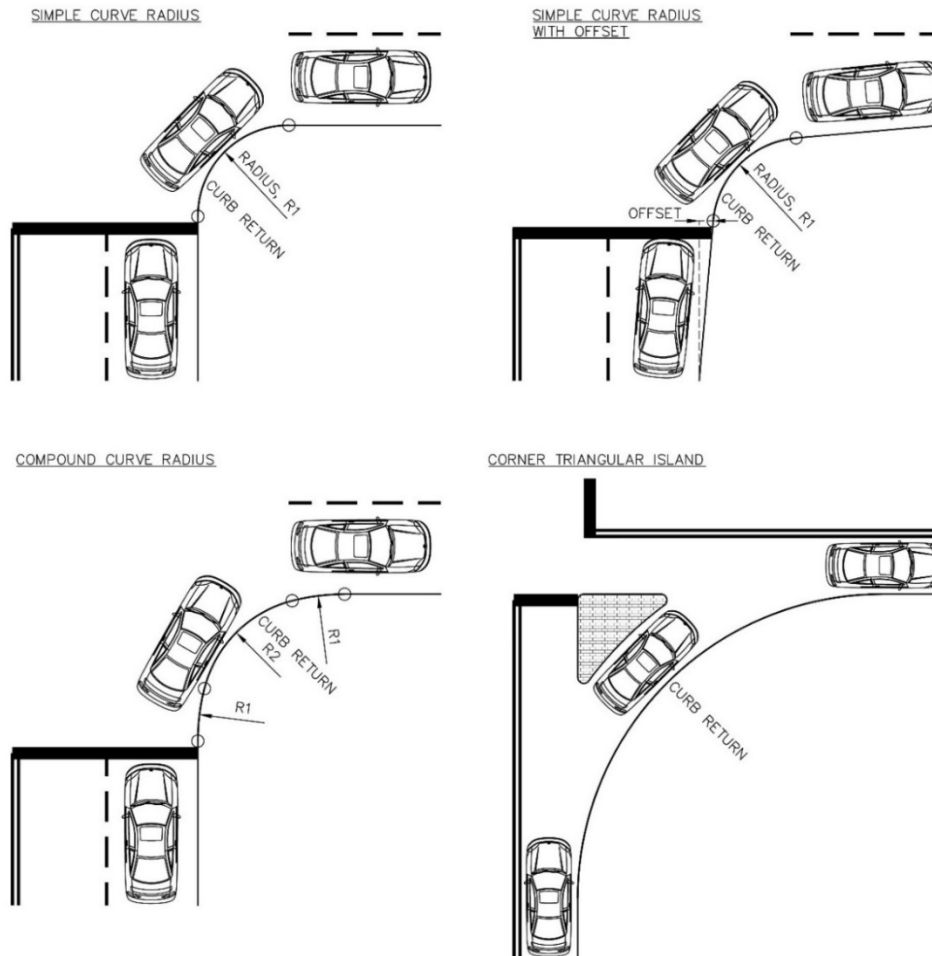

Figure 6-6. Curb Radius Design Types

The AASHTO Green Book provides the recommended curb radii for various design scenarios. The selection of curb return radii should be evaluated with CADD software to determine its compatibility with turns of specific design vehicles. The minimum curb radii for various street types can be found below in **Table 6-3**.

Table 6-3. Minimum Curb Radii

Street Type	Minimum Radius (ft)
Activity Streets	25'
Commerce/ Mixed-Use Streets	30' – 50'
Neighborhood Connectors	30' – 40'
Commercial Connectors	40' – 50'
System Links	40' – 50'

6.7.5 Channelization

Potential vehicle to vehicle conflicts and vehicle to pedestrians or bicyclist conflicts may be reduced through channelization. Channelization provides positive guidance to motorists and helps separate and direct traffic movements into specific and clearly-defined vehicle paths. Channelization can be achieved through traffic islands or pavement markings. Channelization is also used for the following purposes:

- To control the angle of conflict.
- To control vehicle speeds in merging, diverging, weaving, and crossing maneuvers.
- To block prohibited maneuvers.
- To reduce excess pavement areas (large areas of open pavement may confuse drivers).
- To locate and protect traffic control devices.
- To protect pedestrians by providing one or more safe refuges.

Traffic islands make up a defined area between traffic lanes. Islands have three main functions: to control and direct traffic movement (channelizing islands), to separate opposing traffic flows (divisional islands), and/or to provide a refuge or protect pedestrians crossing the roadway (refuge islands). Channelizing islands often have a triangular shape and separate right-turning traffic. Good channelization design should adhere to the following principles:

- Islands should be placed so that the path of travel is obvious and natural.
- The number of islands should be held to a practical minimum to avoid confusion.
- Islands should be large enough to be effective as a method of guidance and not cause problems in maintenance.
- Islands designed for turning traffic should have a radius equal to or larger than the minimum turning radii.
- Islands should be designed for the target speed of the road.
- Drivers approaching an island should be alerted through a gradual widening in the road delineated with markings or rumble strips.
- If there is pedestrian cut-through at the island, it should be sized adequately to provide an ADA accessible path and curb ramps.

- Islands should be sufficiently large to command attention. The smallest curbed island should have an area of approximately 50 square feet, preferably 75 square feet. When accommodating an ADA accessible path, the smallest curbed island should have an area of 75 square feet, preferably 100 square feet.

In addition to channelizing islands, divisional islands and refuge islands are also common in intersection areas. Divisional islands are used to divide opposing or same direction traffic streams, whereas refuge islands are used to separate pedestrian and bicyclists from vehicular traffic to provide safe refuge, especially during crossing the intersections. **Figure 6-7** shows examples of different types of islands.

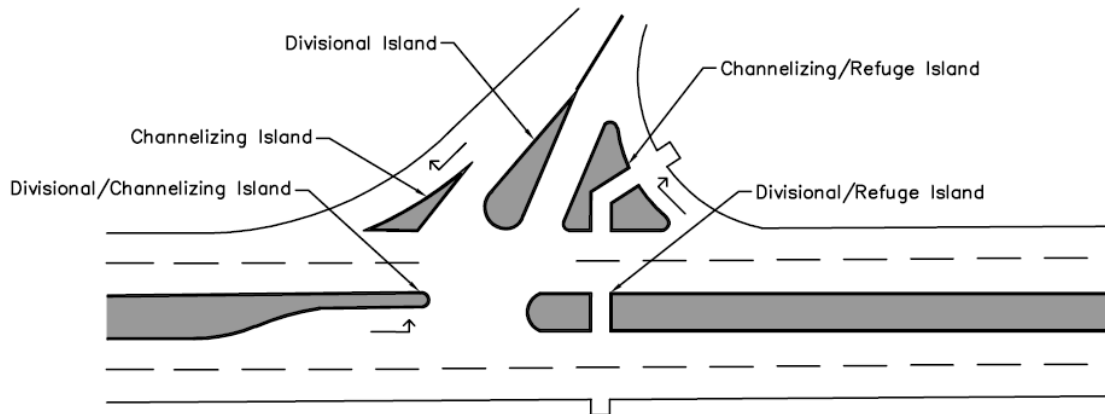

Figure 6-7. Types of Islands

Delineation of islands is critical to good channelization design. Islands can be outlined by curbs, pavement markings, delineators on posts, or appropriate landscaping. Raised, curbed islands are most effective when applied to urban streets where target speeds are low (preferably 35 mph or less). Striped islands are most effective when used in areas where space is limited, such as when less than 50 square feet is available. They can also be used to test temporary configurations before a raised island is constructed.

6.7.6 Auxiliary lanes

Auxiliary lanes are used at intersections to accommodate turning movements. These lanes reduce the potential for conflicts caused by speed differentials between turning and through traffic by removing turning traffic from the through lanes. Auxiliary lanes also increase intersection capacity and facilitate safe turning movements. Auxiliary lanes may also be provided for acceleration for merging or weaving after completing right- or left-turns at the intersection.

The width of the auxiliary lanes should be at least 10 feet wide and preferably match the width of the through lanes. The length of an auxiliary lane should be sufficient to provide required vehicle storage queue based on the traffic analysis. Even though reducing shoulder width is not desirable, it is acceptable to reduce the shoulder width to provide auxiliary lanes at the intersection.

Standard warrants for auxiliary lanes do not exist. However, general conclusions to consider when designing for an auxiliary lane include the following:

- Refer to the City's [Access Management Policy](#) for specific locations and conditions where right- and left-turn auxiliary lanes must be provided.
- Auxiliary lanes should be long enough for a driver to maneuver into the lane and decrease or increase speed to perform the turning or merging maneuver.
- Auxiliary lanes can also function as storage lanes and should be long enough to provide sufficient storage length for vehicles waiting on an opportunity to turn.

The right and left turn auxiliary lanes at intersections are deceleration lanes which consists of the entering taper length, the deceleration length, and the queue storage length, as shown in **Figure 6-8**. Detailed requirements on when and where to consider left- and right-turn lanes are outlined in the City's [Access Management Policy](#).

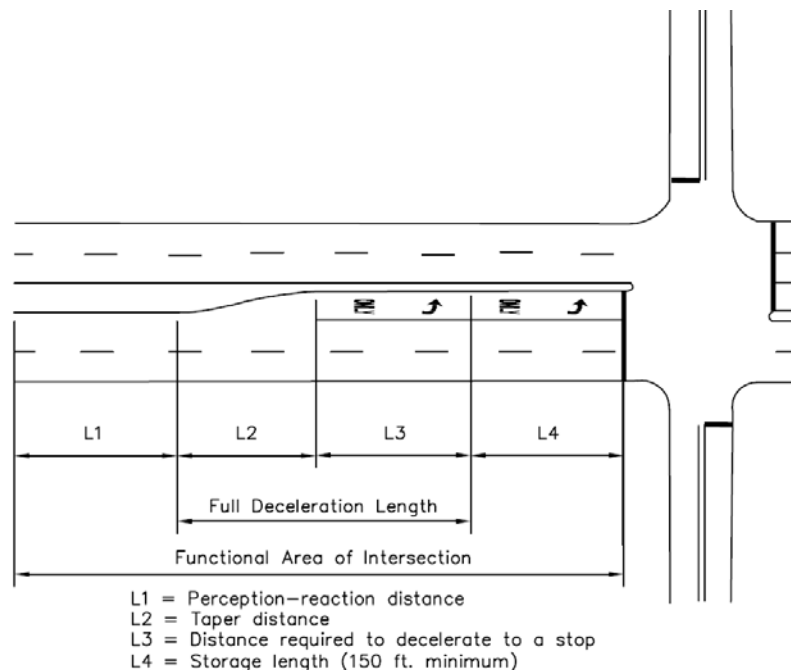

Figure 6-8. Auxiliary Turn Lane Components

6.7.6.1 Deceleration Length

The deceleration length is the length needed for drivers to transition into the turn lane from the through lane and come to a stop. The latest edition of the AASHTO Green Book includes desirable full deceleration lengths based on speed which are applicable to left- and right-turning vehicles, though approach speed is usually lower for right-turning traffic. If space constrictions only allow part of the deceleration lane to fit within the functional area of the intersection, then part of the deceleration will need to be done before entering the auxiliary lane. A 10-mph speed differential is considered acceptable on thoroughfares.

6.7.6.2 Storage Length

Storage length is based on the number of vehicles that will accumulate at a time. The storage length should be sufficient to store the number of vehicles that are likely to accumulate during a certain period. Storage length for right turn and left turn auxiliary lane should be determined based on the traffic analysis. The recommended storage length is the 99.5th percentile queue length,

which is the distance at which 99.5% of the left-turning traffic queues will be at or below. It should be long enough so that turning traffic does not back up onto through-traffic lanes. In cases with no to little volume information, the storage length should at least be 150 feet or as directed by TPW.

6.7.6.3 Taper Length

The taper for developing left and right turn auxiliary lanes should be provided as shown on the AASHTO Green Book. Shorter taper lengths are preferred in urban areas for alerting drivers of an auxiliary lane in urban intersections due to higher volumes and slower speeds. Shorter taper lengths can range from 50 feet for a single-turn lane and 100 feet for a dual-turn lane. Larger taper lengths may be provided for the smooth transition of traffic from through lanes to auxiliary lanes.

6.7.6.4 Left-Turn Channelization

Left-turn lanes separate left-turning traffic from through traffic which reduces the potential for rear-end collisions. Refer to the City's [Access Management Policy](#) for specific locations and conditions where left-turn lanes are needed as well as spacing requirements for median openings. Left-turn lanes in medians are auxiliary lanes used for the storage and deceleration of left-turning vehicles. Left-turn lanes must be provided at all median openings that allow left turns on streets with medians. Standard medians are typically used to accommodate left-turn lanes at intersections. Wide medians are used along corridors that need dual left-turn lanes. New left-turn lanes that are built in wide medians (28 ft.) should be designed to have a 3.5-foot or more positive offset between opposing left-turns. Positive offset left-turn lanes have proven to reduce crash rates by improving visibility. The outside lane of the offset is often striped. Intersections with a negative or no offset can increase the chances of collisions between opposing traffic. **Figure 6-9** shows the different types of left-turn offsets.

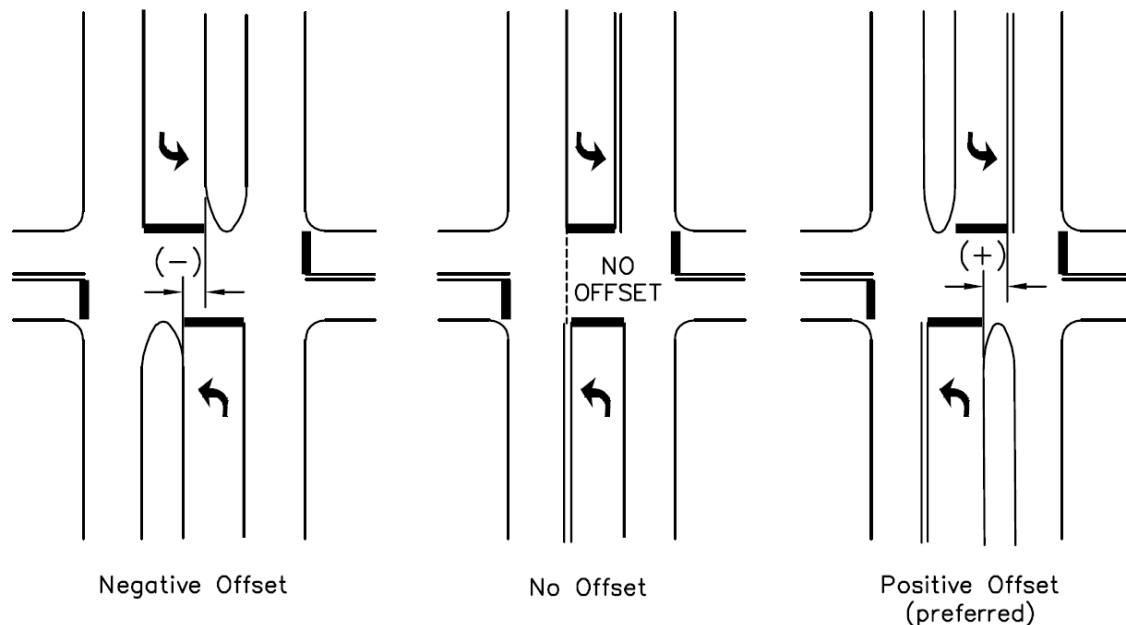

Figure 6-9. Left-Turn Lane Offsets

Physical channelization of left-turns emphasizes the separation with through traffic. Advantages of channelization include:

- Improved visibility for left-turn traffic.
- More clearly defined turning paths.
- Fewer sideswipe collisions caused by through traffic changing lanes.
- Provides median refuge.
- Added space for landscaping and intersection beautification.

Left-turn channelization design should incorporate the design vehicle, cross section, volumes, speeds, type of intersection control, and pedestrian and transit activity. The channelization should smoothly guide drivers into the turn movement. Channelization is often provided through concrete islands, striped islands, or delineators. Pavement marking channelization can better provide for the larger design vehicles and are easier to install; however, they can be more difficult to see at night. Raised islands are easier to see but should not present an obstruction to vehicles.

The pavement markings and signing for auxiliary lanes at the intersections should be done in accordance with the City's standards and the [TMUTCD](#).

6.7.7 Curb Extensions (Bulbouts)

Curb extensions, or bulbouts, decrease the width of the roadway at intersections. This improves safety by reducing the crossing distance of pedestrians, slows turning speeds of vehicles with tighter curb radii and protects important sight lines. Curb extensions serve as visual reminders for drivers entering an urban environment to proceed cautiously. Curb extensions are often placed in pedestrian heavy environments. Curb extensions also increase space for additional landscaping including street furniture, benches, and trees. Curb extensions can also provide better accommodation for on-street parking, and better assurance that emergency responders and large vehicles have access to streets. Curb extensions shall not negatively impact gutter flow or cause drainage issues. **Figure 6-10** shows an example of curb extensions at midblock and at an intersection.

[NACTO Urban Street Design Guide](#) recommends the following guidelines for the design of curb extensions:

- The length of the curb extension should at least equal the width of the crosswalk, preferably extending to the stop bar.
- The width of the curb extension is generally 1-2 feet shorter than the width of an adjacent parking lane, except when the design of the parking lane is meant to continue to the sidewalk.
- Temporary curb extensions can be tested with signing and pavement markings prior to implementing final curb extension.

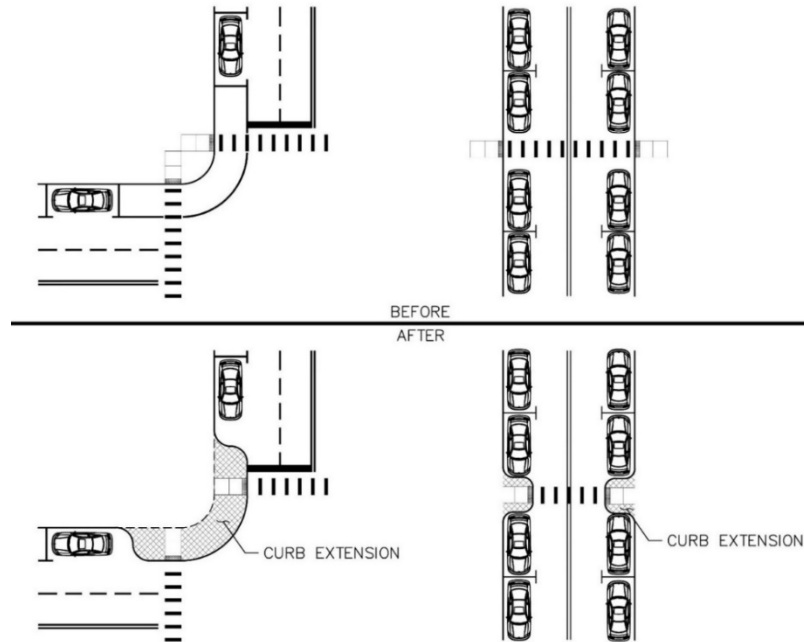

Figure 6-10. Curb Extension Applications

6.7.8 Controlled Crosswalks

At controlled crosswalks, best practice calls for all legs of the intersection to be marked with a crosswalk to reduce pedestrian delay and enhance mobility. Pedestrians are unlikely to travel extra distances to cross a roadway, so leaving one or more legs of an intersection unmarked would only make that crossing choice less visible to motorists. A leg should be left unmarked only when a significant safety reason exists to forbid pedestrians from crossing.

Advance stop bars at stop or signal-controlled intersections show the motorist the proper place to stop so that the vehicle does not encroach upon the pedestrian crossing. Pedestrians have a better view of the vehicles in the roadway when vehicles are prevented from stopping too close to the crosswalk. The distance between the crosswalk and on-street parking shall be provided in accordance with the [TMUTCD](#) to ensure that pedestrians' sight lines are not blocked by large vehicles.

6.7.9 Curb Ramp Placement

Curb ramp design guidelines are provided in [Chapter 5](#) of this manual. Curb ramps at the intersection must be designed in accordance with [TAS](#) and [PROWAG](#) when located in City right-of-way. Newly installed sidewalk or modifications to existing sidewalk must be designed with curb ramps that are compliant with [TAS](#) and [PROWAG](#).

6.7.10 Median End Treatment

The shape and width of median openings should accommodate turning movements without encroachment onto adjacent lanes. The control radii for minimum turning paths is based on each design vehicle making a minimum left turn at 10 to 15 mph. When the intersection calls for vehicles making a higher speed turn movement, then the radius of the median design can be designed to

accommodate the higher turn speed. The AASHTO Green Book provides minimum 90-degree left turn paths for design vehicles.

The design of median noses should be based on traffic volumes, types of turning vehicles, and the available width. With left-turn lanes, a standard median should be narrowed to no less than 4 feet, though a width of 6-8 feet is preferred. For wider medians, a positive offset of 3.5 feet is preferred between left-turn lanes in opposing directions as shown in **Figure 6-9**. For medians with curbed dividers at least 4 feet or more in width at the end, the curbed nose can be offset at least 2 feet from the normal medial edge. The shape of these curbed nose dividers is usually semicircular. Median ends that have wider widths are usually designed with a bullet shape to better align with the turning path of vehicles.

Median noses should be ramped down at the approach end. Tapered nose designs outlined with pavement marking areas can provide better guidance and visibility to drivers. The approach nose of medians should be properly delineated. The AASHTO Green Book provides more details on divisional median island design.

6.8 OTHER INTERSECTION DESIGNS

6.8.1 Roundabouts

The City is currently developing roundabout design guidelines. Once they have been finalized, this section will be updated. In the interim, designers shall coordinate directly with TPW Capital Delivery group regarding the design of roundabouts.

6.8.2 Skewed Intersection

Ideally, the legs of intersections should cross at close to 90-degree angles. However, it is not always practical to achieve this. When legs of an intersection intersect at excessive skew angles, it increases the time needed for crossing and turning maneuvers. The excessive skew also has negative impacts on intersection sight distances and creates operational and safety issues at intersections. Therefore, when the intersecting angles are less than 60 degrees, it is preferred to evaluate intersection modification alternatives for a skew reduction or realignment.

The realignment of these skewed intersection can be achieved by constructing short-radius horizontal curves on the minor road approaches whenever practical. Some of the intersection realignment options to reduce skew angles is shown in **Figure 6-11**.

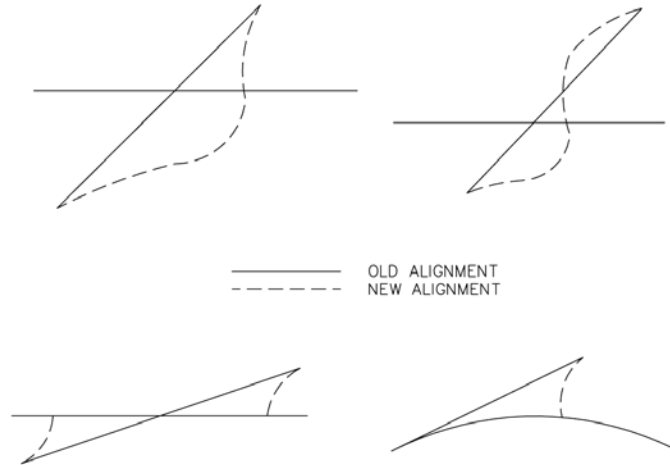

Figure 6-11. Intersection Realignment Options (AASHTO Green Book (2018))

6.8.3 Multi-Leg Intersection

Multi-leg intersections are intersections with five or more legs. These should be avoided when possible. If unavoidable, multi-leg intersections should ideally share a common paved area and be in an area with low volumes. Stop control is the preferred method of control. If located in a high-volume area, reconfiguration/realignment is the preferred method to improve the intersection.

Options to reconfigure an existing multi-leg intersection include the following:

- Redesigning the intersection to a roundabout.
- Converting one or more legs to one-way operation.
- Realigning a leg to intersect with an adjacent leg some distance away from the existing intersection.
- Realigning two of the legs to intersect with each other some distance away from the existing intersection.

The realignment of any of the legs should be so that the new intersection is created along the minor street. The operation within the functional areas of the newly created intersection should not interfere with those of the surrounding intersections. This is important to consider when determining the sufficient distance that the new leg should intersect. When working in a limited space, further evaluation should be done to ensure that more conflicts or increased delays are not introduced with the realignment.

Figure 6-12 shows examples of realigning multi-leg intersections.

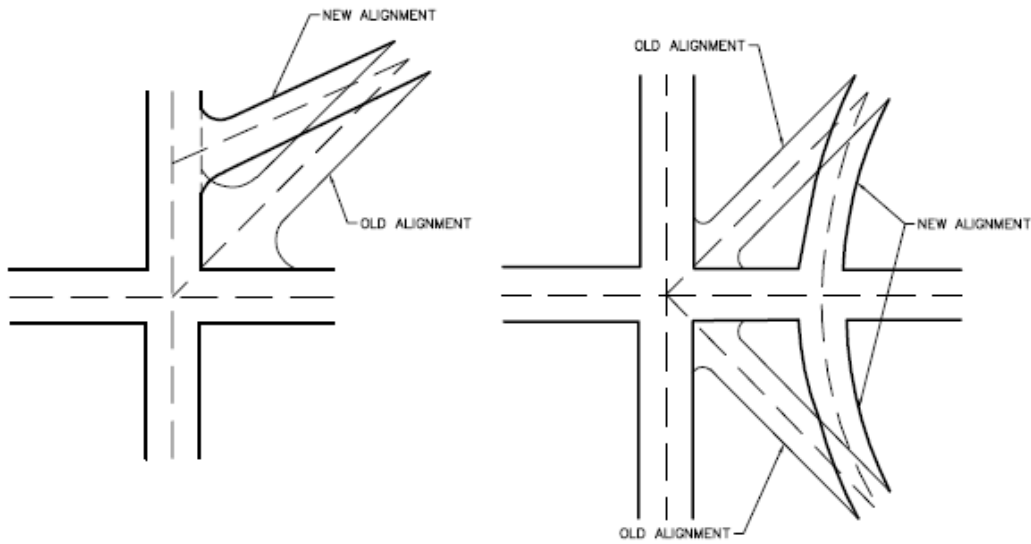

Figure 6-12. Realigning Multi-Leg Intersections (AASHTO Green Book (2018))

6.9 INTERSECTION CONTROL

The types of traffic control implemented at an intersection is a key element for its operations. Types of intersection control include following:

- Uncontrolled Intersection
- Yield Controlled Intersection (Primarily for Roundabout)
- Stop – Controlled Intersection
 - Two-Way Stop Controlled
 - All-Way Stop Controlled
- Signalized Intersection

6.9.1 Uncontrolled Intersection

Uncontrolled intersections are the intersections without any signage for stop, yield or any other traffic control devices. Vehicles arriving at the same time to the intersection with no control device yield to the vehicle on the right. These intersection types are typical at low volume road and driveway intersections. These types of intersection controls should not be used in the high traffic volume and in the areas with past safety issues.

6.9.2 Yield Controlled Intersection

Yield controlled intersections assign right-of-way without requiring a stop. They are typically found at right-turn lanes of an intersection, three-way intersections, roundabouts, and rural low-volume ramps. They are not recommended at intersections with high pedestrian volumes.

6.9.3 Stop-Controlled Intersection

Stop-controlled intersections are further divided into two-way stop controlled and all-way stop controlled. Two-way stop-controlled intersections require traffic on the minor street to stop and yield right-of-way to major street traffic. Stop signs should only be installed on the minor street approach at two-way stop-controlled intersections. According to the [TMUTCD](#), if two streets with similar volumes intersect, it is recommended to install stop-control on the street with the following characteristics:

- Conflicts the most with pedestrian activity.
- Has dips or bumps along the street that require drivers to proceed slower.
- Has the longest distance of uninterrupted flow approaching the intersection.
- Has the best sight distance to conflicting traffic.

All-way stop controlled intersections require traffic from all directions to stop before entering the intersection. All-way stops are typically installed at lower speed intersecting streets with approximately equal volumes. When all-way stops are installed at inappropriate locations, it can cause increased traffic delays, queuing, fuel consumption and air pollution. According to the [TMUTCD](#), the installation of multi-way stops should be considered in an engineering study that evaluates the following criteria:

- The multi-way stop is to be used as an interim measure before the installation of a traffic signal.
- Five or more reported crashes in a 12-month period that are susceptible to correction by a multi-way stop installation.
- The intersection meets the minimum volume requirements outlined in the [TMUTCD](#).

6.9.4 Signalized Intersection

A signalized intersection is the intersection control that is typically used at high-speed or high-volume intersections. Traffic signals offer many benefits including increased capacity compared to stop-controlled intersections, improved progression through a corridor, opportunities for other traffic to enter the intersection by interrupting major street traffic, and provide preemption service. Some of the disadvantages to traffic signals include regular maintenance requirements, susceptibility to power outages and detection failures, and an increase in certain types of crashes compared to roundabouts. According to the [TMUTCD](#), the installation of a traffic control signal should include an analysis of existing operations and safety and consideration of the factors included in the following warrants:

- Warrant 1 – Eight-Hour Vehicular Volume
- Warrant 2 – Four-Hour Vehicular Volume
- Warrant 3 – Peak Hour
- Warrant 4 – Pedestrian Volume
- Warrant 5 – School Crossing
- Warrant 6 – Coordinated Signal system
- Warrant 7 – Crash Experience

- Warrant 8 – Roadway Network
- Warrant 9 – Intersection Near a Grade Crossing

The satisfaction of a warrant should not in itself require the installation of a signal. It should be noted that not all crashes are correctable with the installation of a traffic signal. Although right-angle crashes are less frequent, rear-end crashes are more likely. For additional information on traffic signal warrant analysis, refer to the [TMUTCD](#).

6.9.4.1 *Traffic Control Signal and Pedestrian Signal Installation Policy*

Purpose

This policy is intended to establish guidelines and responsibilities for the operation, maintenance, and financing of traffic control signal and pedestrian signal installations, which are warranted by an engineering investigation conducted by the Transportation Management Division and/or TxDOT and determined to be in the best interest of the public.

Definition

A traffic signal installation shall include the traffic signal and all auxiliary material and equipment located within the public right-of-way and within secured easements, necessary to control vehicular and pedestrian traffic in the manner intended by the Transportation Management Division and/or TxDOT.

General

The City Traffic Engineer shall be responsible for the installation, maintenance, and operation of all traffic signals within the City with the following exceptions:

- a) The installation of traffic signals on freeway frontage roads which are financed and installed by TxDOT. These shall, upon completion of construction, be maintained and operated by the City.
- b) The installation or revision of traffic signals in connection with the improvement of streets and highways under a Federal-aid and/or State-aid program. These shall, upon completion of construction, be maintained and operated by the City.

Policy and Procedures

The following paragraphs describe the procedures used by the Transportation Management Division for the installation of traffic signals.

- a) When the City receives a request for a traffic signal from any citizen, or when staff determines that a signal may be needed, a Traffic Signal Warrant Study shall be initiated.
- b) The Traffic Signal Warrant Study shall be conducted by the Transportation Management Division as prescribed in the [TMUTCD](#).
- c) If the location does not meet any of the warrants for a traffic signal installation, the party requesting the signal shall be notified that a study has been conducted and it was found that a traffic signal is not warranted. In addition, they shall be advised that the Transportation Management Division shall continue to monitor traffic conditions in the area so that if and when a traffic signal becomes warranted, and staff has determined that a traffic signal can be installed without creating a hazard or serious disruption of traffic flow, it shall be recommended

to the City Council for their consideration. The information collected during the initial and any subsequent study shall be placed in a permanent file for future reference.

- d) Since meeting warrants by itself cannot justify the installation of a signal, further analysis shall be made by the Transportation Management Division and the following questions will be asked:
 1. Will the proposed traffic signal correct the prescribed problem?
 2. If the signal is installed, will the desired results be achieved?
 3. Do the physical geometrics of the intersection and the approaches allow the installation of a traffic signal? If not, what are the changes necessary?
 4. Are funds available to install the traffic signal?
 5. Will the signal not have a substantially negative impact to arterial traffic flow?
- e) Final recommendation: If the answers to the above questions are yes, the traffic signal request supports installation of a traffic signal, and it will be put on the list.
- f) If the geometrics of the location are such that a traffic signal cannot be installed until the intersection is reconstructed, the Transportation Management staff will prepare a drawing of existing conditions with the proposed changes that are necessary. This will be submitted to the TPW Department with a request that work be initiated for the reconstruction of the intersection.
- g) If the location is on the frontage road of a freeway or interstate highway and a traffic signal is warranted, a copy of the study shall be sent to TxDOT with a request for a signal to be installed.
- h) After the City Council approves the projects, detailed engineering drawings of the traffic signal installation will be prepared which include requirements for the traffic signals and the related electronic control equipment. Upon completion of the engineering drawings, work orders will be issued, and construction of the traffic signal installation will begin. While the construction work is progressing, the electronic control equipment is obtained from the Transportation Management Division warehouse and set up in the Signal Shop. The equipment is then tested under simulated operating conditions to ensure that it is operating properly prior to being installed on the street.
- i) As soon as the construction work is completed (conduit, detectors, pole bases, poles, wiring, mast arms/span wires, signal heads, pedestrian push buttons, street lights and appropriate signing, etc.) the electronic control equipment is installed in the equipment cabinet and hooked-up. The signal is then turned on, operationally checked out, and placed in operation.
- j) Once in operation, the signal is maintained by a staff of signal technicians who provide on-call service, as required, 24-hours per day, 365 days per year.
- k) If circumstances require the traffic signal installation jobs be contracted out to area construction companies, all contracts will be let in accordance with standard City bidding practices and policies established by the Purchasing Department. In addition, all materials and equipment used by contractors shall meet City requirements and specifications, and all work shall be subject to inspection and approval by personnel of the TPW Department.

Financing

Traffic signal installations may be financed in several ways; however, all financing shall be subject to the availability of funds. The following outline summarizes the various combinations of recommended financing.

- a) Responsibility for Financing Installation:

- a. The intersection of two or more public streets – 100% City cost.
 - b. The intersection of a public street and a private driveway:
 - i. Private street or driveway for persons, firms, or corporations organized for profit – 100% cost to the private organization.
 - ii. Private street or driveway for persons, firms, or corporations not organized for profit – 100% cost to the City.
 - c. The intersection of two or more public streets and a private street or driveway:
 - i. Private street or driveway for persons, firms, or corporations not organized for profit – 100% cost to the City.
 - ii. Traffic signal is warranted by traffic on two or more public streets – 100% cost to the City.
 - iii. Traffic signal is warranted by traffic generated by the private street or driveway, and the private street or driveway is for persons, firms or corporations organized for profit – 100% cost to the organization.
 - d. Mid-block pedestrian signal for pedestrians crossing a public street:
 - i. Pedestrian signal serves pedestrian traffic for persons, firms, or corporations organized for profit – 100% cost to the organization.
 - ii. Pedestrian signal serves pedestrian traffic for persons, firms, or corporations not organized for profit – 100% cost to the City.
 - iii. Pedestrian signal serves pedestrian traffic for the public-at-large – 100% cost to the City.
 - e. Traffic signals on frontage roads of State-aid and Federal-aid freeways – 100% cost to State and/or Federal agency.
 - f. Financing of the installation, operation, and maintenance of traffic or pedestrian signals located on the border between the City and another political subdivision shall be by negotiation between the two entities.
- b) Responsibility for Financing Maintenance and Operation
- a. The maintenance and operation of all permanent traffic signals shall be responsibility of the City.

Contents

CHAPTER 7 - MIDBLOCK CROSSING..... 7-2

- 7.1 Introduction 7-2
- 7.2 Applications 7-2
- 7.3 Design Guidelines 7-2
 - 7.3.1 Midblock Crossings Through Medians.....7-3
 - 7.3.1.1 Considerations..... 7-3
 - 7.3.1.2 Guidance 7-3
 - 7.3.2 Raised Crosswalks.....7-4
 - 7.3.2.1 Considerations..... 7-5
 - 7.3.2.2 Guidance 7-5
- 7.4 Types of Midblock Crossing Control 7-6
 - 7.4.1 Non-Actuated Midblock Crossings7-6
 - 7.4.2 Actuated Midblock Crossings7-6
 - 7.4.2.1 Pedestrian Hybrid Beacons (HAWK Signal)..... 7-7
 - 7.4.2.2 Rectangular Rapid Flashing Beacons (RRFB) 7-8
 - 7.4.2.3 Flashing LED Signs 7-9
- 7.5 Midblock Pedestrian Crossing Toolbox..... 7-9

List of Figures

- Figure 7-1. Midblock Crossing Example 7-4
- Figure 7-2. Raised Crosswalk 7-5
- Figure 7-3. Pedestrian HAWK Signal 7-8
- Figure 7-4. Pedestrian RRFB 7-9

List of Tables

- Table 7-1. Pedestrian Crossing Toolbox for Midblock Crossings..... 7-10
- Table 7-2. Recommended Pedestrian Applications at Uncontrolled Crossing Locations 7-11

CHAPTER 7 - MIDBLOCK CROSSING

7.1 INTRODUCTION

Midblock crossings provide a safer way for pedestrians to cross the roadway between established intersections. Most pedestrians prefer to take the direct path to their destinations, often choosing to cross at unsafe or unprotected locations rather than walking farther to the nearest crosswalks at the intersection. This sometimes results in safety issues due to pedestrians crossing multiple lanes with high-speed, high-volume traffic. In the areas with long street block lengths and where pedestrian activity is anticipated, well-designed midblock crossings with enhanced traffic control and geometric features can improve the awareness of less expectant drivers and the safety of pedestrians. When installed at improper locations, pedestrian crossings are less effective at reducing risks to pedestrians and motorists.

At some locations it may be desirable or necessary to provide a grade-separated midblock crossing. Like at-grade crossings, grade-separated crossings must meet accessibility requirements which may include features such as elevators, ramps, landings and handrails. Since they are the most expensive type of pedestrian infrastructure, grade-separated crossings should only be implemented after evaluating existing roadway, traffic and pedestrian path of travel conditions. Generally, they are not recommended. Where grade-separated crossings are poorly located or designed, pedestrians often choose to cross at-grade creating potentially unsafe situations with unexpecting drivers. Therefore, design guidance on the proper type and location of only at-grade midblock crossings is provided in the following sections.

7.2 APPLICATIONS

A pedestrian study should be performed to determine the need and suitable location prior to installing any midblock crossing. Designers should consider existing pedestrian and vehicular traffic volumes and vehicle speeds while accessing the need for a midblock crossing. Future pedestrian and vehicular volumes can be used for the midblock crossing assessment for any upcoming development in the area. A pedestrian tracking survey should be completed to evaluate where and how people cross the street.

7.3 DESIGN GUIDELINES

- Midblock crosswalks should be provided at locations where pedestrians are expected to cross. The midblock crosswalk location should give maximum visibility to both pedestrian and drivers.
- Midblock crossings must be marked with signing and high visibility pavement markings to improve the visibility of crossing pedestrians to drivers, especially at night. Signing and pavement marking design should reference the latest City standards and [TMUTCD](#) guidelines.
- Midblock crossings with raised crosswalks provide better visibility, detection, and recognition to the driver. Refer to the section on raised crosswalks in this chapter for guidance on appropriate applications of raised crosswalks.

- Adequate lighting should be provided at midblock crossings. Ensure proper lighting through either luminaires, light poles, in-roadway lights, or backlit overhead signs.
- Midblock crossings should be provided for bus stops greater than 200 feet from an intersection.

7.3.1 Midblock Crossings Through Medians

Adding a raised median is beneficial at midblock crossing locations as it provides pedestrians with a refuge, while cutting the conflicts they face in half. Crossings through short, raised medians are called crossing islands (also known as center islands, refuge islands, pedestrian islands, pork chops or median slow points).

7.3.1.1 Considerations

- Medians allow pedestrians to cross two-way roadways one direction at a time, minimizing crossing delays. Children, seniors, and persons with disabilities often require larger gaps and time for crossing roadways. By introducing a median to a street, there are more opportunities for gaps since pedestrians only need to look for a safe one-way gap instead of a two-way gap.
- By reducing the time a pedestrian must wait for an acceptable gap, pedestrians are encouraged to cross at the recommended crossing location.

7.3.1.2 Guidance

- Medians should ideally be at least 6 feet wide to allow a pedestrian to take refuge comfortably, to meet [TAS](#) and [PROWAG](#) standards, and to accommodate the typical width of a bicycle. It should be noted that even narrower medians can be used to provide at least some buffer to pedestrians, but it is not recommended for pedestrians to use these medians as a refuge because of the proximity to travel lanes. Considerations should be given to narrowing travel lanes to create a wider median to provide pedestrian refuge at midblock crossing locations.
- The median refuge as well as any narrow median cut through shall be provided to comply with [TAS](#) and [PROWAG](#).
- The median refuge should be aligned directly with marked crosswalks and provide an accessible route of travel.
- Where midblock crosswalks are installed at uncontrolled locations across an undivided street or street with a flush median, crossing islands should be considered as a supplement to the crosswalk.
- Crossings through medians can be designed with a slight stagger, forcing pedestrians to face oncoming traffic before progressing through the second phase of the crossing.
- If there is enough width, midblock crossings through medians can be accompanied by curb extensions to create a highly visible pedestrian crossing and provide effective traffic calming.

Figure 7-1 shows an example of a midblock crossing location through a median with lighting, curb ramps, a cut through ramp, curb extensions, and a marked crosswalk.

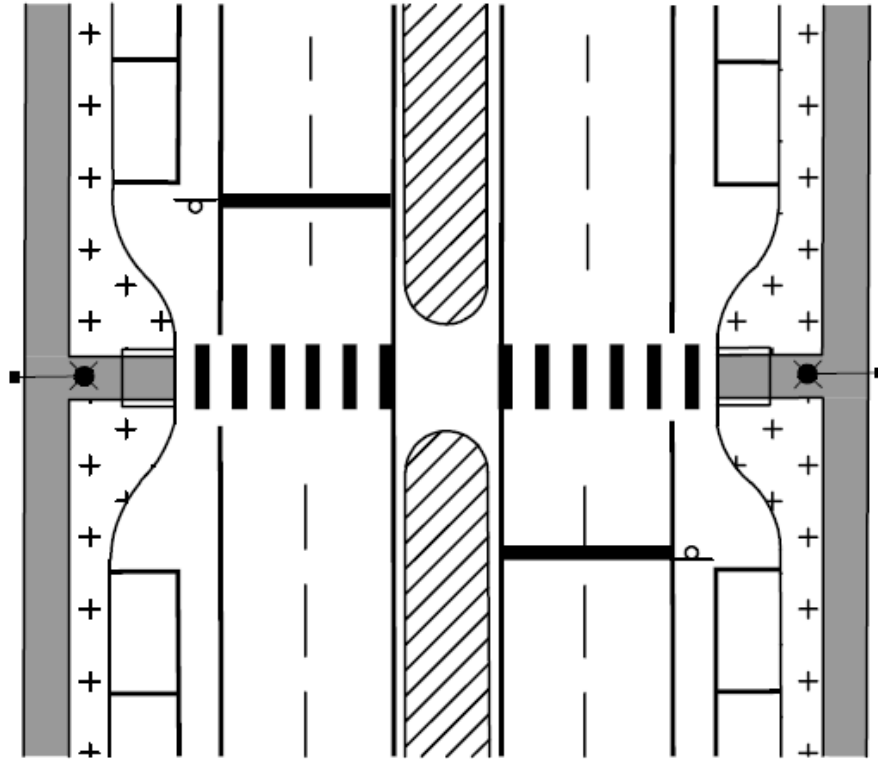

Figure 7-1. Midblock Crossing Example

7.3.2 Raised Crosswalks

A speed table located at a pedestrian crossing, called a raised crosswalk, is a crosswalk at the same level as the sidewalk along the entire width of the roadway or intersection. They eliminate the need for pedestrians to use curb ramps to enter the crosswalk unless the raised crosswalk is across an open street without curb. Ramps are added to the roadway to slow incoming vehicles. Raised crosswalks provide pedestrians with an elevated view of incoming vehicles. They are often placed at midblock crossing locations and intersections though they can also be used as a traffic calming device near schools and parks. Existing drainage patterns should be evaluated before a raised crosswalk is implemented.

Figure 7-2 shows an example of a raised crosswalk.

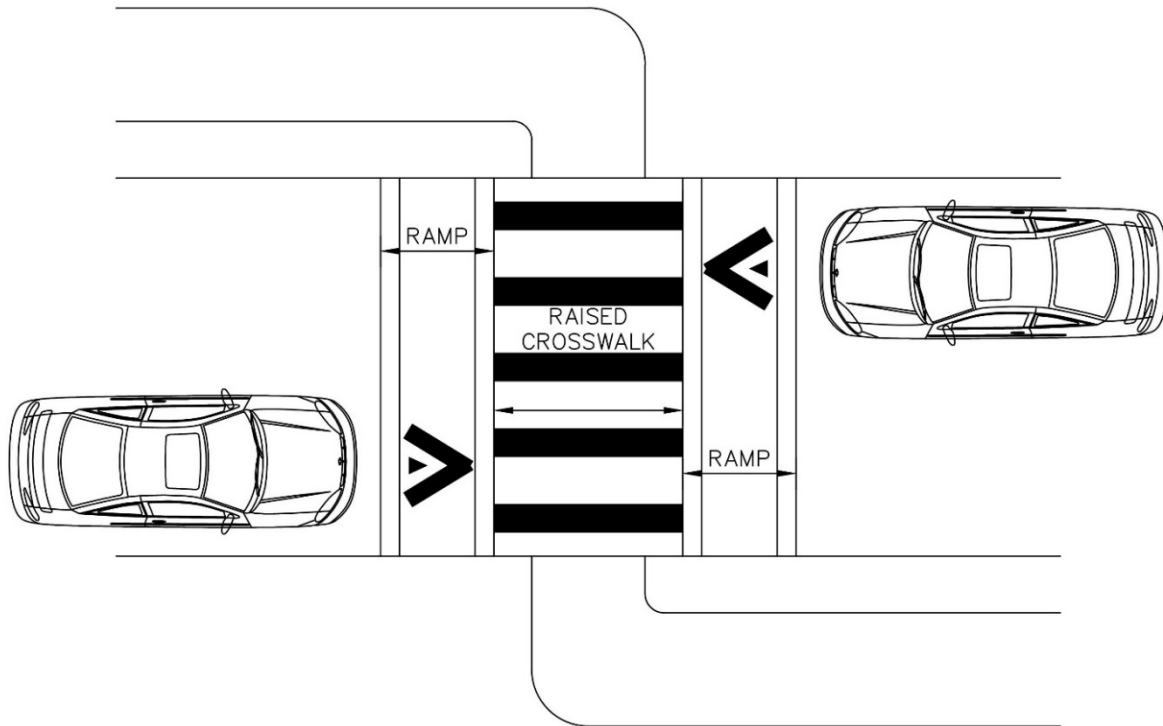

Figure 7-2. Raised Crosswalk

7.3.2.1 Considerations

- Raised crosswalks make crossing pedestrians more visible to drivers.
- Crossings are more accessible by allowing pedestrians to cross at a nearly constant grade.
- Approach ramps that reduce vehicle speeds improve motorist yielding.
- Can be used at both non-actuated and actuated midblock crossings and locations with on-street parking and bicycle facilities.

7.3.2.2 Guidance

- Most applicable on local streets, collectors, and commerce/mixed-use streets with one to three auto or transit lanes and an AADT less than 9,000 vpd. Traffic volume does not need to be considered if the crosswalk is in an area with high pedestrian volumes and low vehicle speeds.
- Can also be applied near schools and parks.
- Typically designed with a 10-foot flat top and 6-foot approach ramps so that the front and rear wheels of a passenger car can be on the flat top of the speed table at the same time.
- Typically, between 3 and 6 inches above street level and often flush with the curb.
- Detectable warnings must be installed at the street edge to indicate the beginning of the crosswalk for persons with disabilities.

- Should be demarcated with pavement markings and/or special paving materials. Pavement markings on both the flat top and ramp portion of the raised crosswalk must comply with the [TMUTCD](#).
- May not be appropriate on bus transit routes where transit operating speeds are typically greater than 25 mph, primary commercial access routes, or primary emergency vehicle routes.
- Should not be located upstream of a bus stop to avoid the bus crossing the crosswalk as passengers are getting up or sitting down.
- Impacts on drainage should be considered.
- May not be appropriate for crossings on sharp curves or steep roadway grades.
- Can be designed with a curb extension to reduce pedestrian crossing distance.

Refer to the [Traffic Calming ePrimer](#) for additional guidance on raised crosswalks.

7.4 TYPES OF MIDBLOCK CROSSING CONTROL

Depending on the type of pedestrian control provided at the midblock crossing locations, midblock crossings can be broadly classified as follows:

- Non-Actuated Midblock Crossings
- Actuated Midblock Crossings

7.4.1 Non-Actuated Midblock Crossings

Non-actuated midblock crossings are midblock crossings where there is no pedestrian actuation or detection installed at the crossings. For these types of crossings, ADA compliant curb ramps and marked crosswalks shall be provided, at a minimum, depending on the types of roadway being crossed. The crosswalks should be supplemented with necessary signage and pavement markings. At uncontrolled multi-lane crossings, the yield or stop bars should be placed 20 to 50 feet in advance of the nearest crosswalk with parking prohibited within that space to provide drivers with a better visibility of the crosswalk. Curb extensions may be considered as a replacement for parking spaces to reduce pedestrian crossing distance and visually alert drivers of the crossing ahead. If a non-actuated crossing is located near a transit stop, it should be placed upstream of the transit stop location so pedestrians can cross behind the bus or transit vehicle. Pavement markings and signage for crossings should be provided in accordance with the [TMUTCD](#) and City standards.

7.4.2 Actuated Midblock Crossings

Actuated midblock crossings are the midblock crossing where pedestrian actuation or detection is installed at the crossings. These detections are typically provided through push button detection. According to FHWA, actuated midblock crossings should be considered under the following conditions:

- On high traffic volume and/or high-speed traffic roadways.
- Where there are infrequent gaps in traffic.
- In a school zone or within an area with a high number of young pedestrians.
- Where seniors and persons with disabilities frequently cross.

The main types of actuated midblock crossing devices are HAWK (High-Intensity Activated Crosswalk) signals commonly known as Pedestrian Hybrid Beacons (PHB), Rectangular Rapid Flashing Beacons (RRFB), and flashing LED signs. Flashing LED signs are the preferred actuated control at midblock crossings for the City.

All curb ramps, push buttons and crosswalks installed should be compliant with the [TAS](#) and [PROWAG](#). These devices shall be installed in accordance with the latest edition of [TMUTCD](#) and City standards.

7.4.2.1 Pedestrian Hybrid Beacons (HAWK Signal)

A HAWK, as shown in **Figure 7-3**, is a signalized traffic control device designed to help pedestrians cross the street by stopping traffic. It is made up of two red lenses and a yellow lens. A HAWK signal should be considered on roadways with the following conditions:

- AADT > 9,000;
- Number of lanes \geq 3; and
- Speed limit > 40 mph.

According to the [TMUTCD](#), midblock crossings should not be signalized if they are located within 300 feet of the nearest traffic signal, unless the proposed signalization will not restrict progression of traffic. The crossing should also not be signalized if located within 100 feet from a stop- or yield-controlled intersection with a street or driveway.

Midblock signals can cause problems if pedestrians perceive the signal to hold them back from crossing when there is a sufficient gap. This can cause them to cross before the appropriate signal indication, forcing drivers to stop at false signal indications with no crossing pedestrians. This increases driver frustration and non-compliance. Therefore, it is recommended that midblock signals have an immediate response when actuated by pushing the pedestrian call button. Immediate response of the HAWK signal should only be installed if nearby signals are not in progression or if only used during off-peak hours. If the HAWK signal is close to other signals, it should be part of an overall coordinated system to maintain progression. If there is a median refuge at the Hawk signal, push buttons shall be at the median refuge to reactivate the HAWK signal. The [TMUTCD](#) and City standard details provides further guidelines and warrant criteria for the installation of HAWK signal.

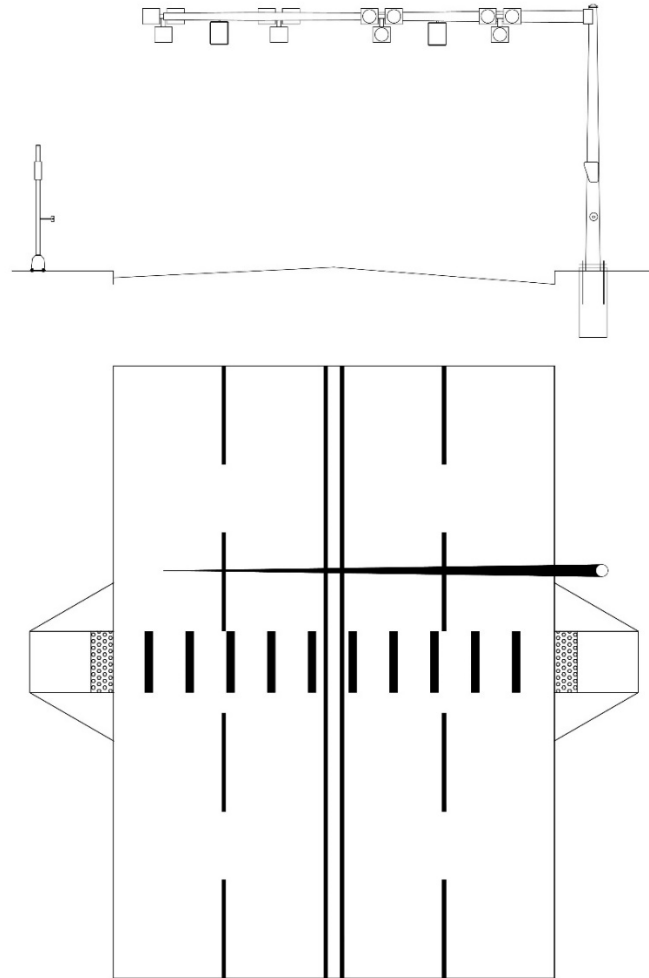

Figure 7-3. Pedestrian HAWK Signal

7.4.2.2 Rectangular Rapid Flashing Beacons (RRFB)

RRFBs, as shown in **Figure 7-4**, are pedestrian activated beacons which supplement the midblock crossings by providing additional warning to the drivers. RRFBs can be activated by either passive (by a pedestrian detection system) or active (by physically pushing a push button) pedestrian detection. The most common type of detection is the push button detection. They usually supplement warning signs, operate similarly to emergency flashers, and remain flashing to provide adequate pedestrian crossing time in accordance with **TMUTCD** when activated. Compliance is likely to increase when installing RRFBs on either side of the crosswalk facing oncoming traffic. RRFBs can be installed on two-lane and multilane roadways.

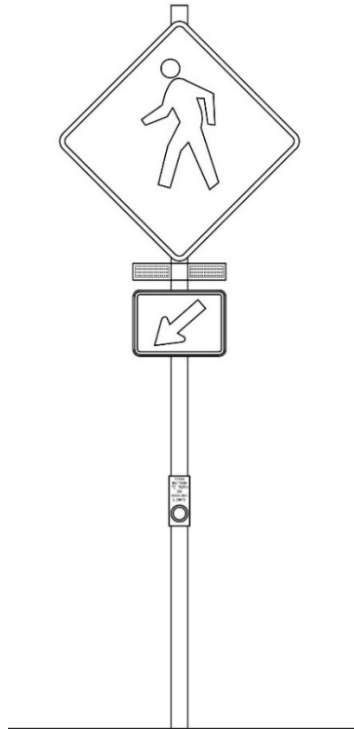

Figure 7-4. Pedestrian RRFB

7.4.2.3 Flashing LED Signs

Flashing Light Emitting Diodes (LED) signs are the preferred actuated control at midblock crossings for the City. By imbedding LED units to the warning signs, there are benefits of improved driver compliance and enhanced visibility in low light conditions. Due to the low power requirements of LEDs, flashing LED signs can be powered with stand-alone solar panel units. When installed at midblock crossings, the pedestrian warning sign (W11-2) is embedded with flashing LEDs. The signs are set to flash with active or passive pedestrian detection. One double sided flashing LED sign or two single sided flashing LED signs should be installed at each side of the crosswalk. When used, the LED-embedded signs must conform to the requirements set in the [TMUTCD](#).

7.5 MIDBLOCK PEDESTRIAN CROSSING TOOLBOX

Table 7-1 shows the most common pedestrian elements for midblock crossings and a summary of important considerations.

Table 7-1. Pedestrian Crossing Toolbox for Midblock Crossings

Pedestrian Toolbox Element		Considerations
Marked Crosswalk		High visibility crosswalk markings should be used at every midblock crossing.
Raised Crosswalk		Can be installed on local roads, collectors, and street types with \leq 25 mph target speeds, one to three lanes, and an AADT < 9,000 vpd.
Pedestrian Lighting		Ensure proper lighting of the crosswalk through either luminaires, light poles, in-roadway lights or backlit overhead signs.
Pedestrian Beacons	Rectangular Rapid Flashing Beacon (RRFB)/ Flashing LED Sign	Can be installed on local roads, collectors, and low-volume, fewer than five lane activity streets, commerce/mixed-use streets, and neighborhood connectors. Install at high volume pedestrian and bicycle crossings along priority pedestrian/bicycle routes.
	Pedestrian Hybrid Beacon (HAWK Signal)	Any unsignalized designated crossings of roadways with three or more lanes and high traffic volumes.
		The MUTCD recommends minimum volumes of 20 pedestrians or bicyclists an hour for major arterial crossings.
Pedestrian Signal Timing and Countdown Indicator		Any signalized midblock crossing.

According to the [Guide for Improving Pedestrian Safety at Uncontrolled Crossing Locations](#), the FHWA recommends different applications at uncontrolled crossing locations based on roadway geometry and traffic information as shown in **Table 7-2**. These applications can be used at both midblock crossings and intersections.

Table 7-2. Recommended Pedestrian Applications at Uncontrolled Crossing Locations

Roadway Configuration	Speed Limit								
	≤30 mph	35 mph	≥40 mph	≤30 mph	35 mph	≥40 mph	≤30 mph	35 mph	≥40 mph
	Vehicle AADT <9,000			Vehicle AADT 9,000–15,000			Vehicle AADT >15,000		
2 lanes*	1 2 3 4 5 6	1 3 5 6 7	1 3 5 6 7	1 3 4 5 6	1 3 5 6 7	1 3 5 6 7	1 3 4 5 6 7	1 3 5 6 7	1 3 5 6 7
3 lanes with raised median*	1 2 3 4 5	1 3 5 7	1 3 5 7	1 3 4 5 7	1 3 5 7	1 3 5 7	1 3 4 5 7	1 3 5 7	1 3 5 7
3 lanes w/o raised median†	1 2 3 4 5 6 7	1 3 5 6 7	1 3 5 6 7	1 3 4 5 6 7	1 3 5 6 7	1 3 5 6 7	1 3 4 5 6 7	1 3 5 6 7	1 3 5 6 7
4+ lanes with raised median‡	1 3 5	1 3 5 7	1 3 5 7	1 3 5 7	1 3 5 7	1 3 5 7	1 3 5 7	1 3 5 7	1 3 5 7
4+ lanes w/o raised median‡	1 3 5 6 7 8	1 3 5 6 7 8	1 3 5 6 7 8	1 3 5 6 7 8	1 3 5 6 7 8	1 3 5 6 7 8	1 3 5 6 7 8	1 3 5 6 7 8	1 3 5 6 7 8

*One lane in each direction †One lane in each direction with two-way left-turn lane ‡Two or more lanes in each direction

Given the set of conditions in a cell,

- Ⓢ Signifies that the countermeasure should always be considered, but not mandated or required, based upon engineering judgment at a marked uncontrolled crossing location.
- # Signifies that the countermeasure is a candidate treatment at a marked uncontrolled crossing location.

The absence of a number signifies that the countermeasure is generally not an appropriate treatment, but exceptions may be considered following engineering judgment.

- 1 High-visibility crosswalk markings, parking restriction on crosswalk approach, adequate nighttime lighting levels
- 2 Raised crosswalk
- 3 Advance Yield Here To (Stop Here For) Pedestrians sign and yield (stop) line
- 4 In-Street Pedestrian Crossing sign
- 5 Curb extension
- 6 Pedestrian refuge island
- 7 Pedestrian Hybrid Beacon
- 8 Road Diet

This table was developed using information from: Zegeer, C. V., Stewart, J. R., Huang, H. H., Lagerwey, P. A., Feaganes, J., & Campbell, B. J. (2005). Safety effects of marked versus unmarked crosswalks at uncontrolled locations: Final report and recommended guidelines (No. FHWA-HRT-04-100); Manual on Uniform Traffic Control Devices, 2009 Edition, Chapter 4F. Pedestrian Hybrid Beacons; the Crash Modification Factors (CMF) Clearinghouse website (<http://www.cmfclearinghouse.org>); and the Pedestrian Safety Guide and Countermeasure Selection System (PEDSAFE) website (<http://www.pedbikesafe.org/PEDSAFE/>).

Source: Guide for Improving Pedestrian Safety at Uncontrolled Crossing Locations (FHWA, 2017)

Rectangular rapid flashing beacons (RRFB) and Flashing LED signs can be used instead of Pedestrian Hybrid Beacons as shown in **Table 7-2** at the City’s discretion.

Contents



CHAPTER 8 - ACCESS CONTROL AND OFF-STREET PARKING 8-2

- 8.1 Introduction 8-2
- 8.2 Access Control 8-2
 - 8.2.1 Highways 8-2
 - 8.2.2 City Streets 8-2
- 8.3 Access Design..... 8-2
 - 8.3.1 Number of Access Points 8-2
 - 8.3.2 Driveway Design 8-3
 - 8.3.3 Driveway Spacing 8-3
- 8.4 Parking Lot Design 8-6
 - 8.4.1 Design Guidelines 8-7
 - 8.4.1.1 Space Size 8-7
 - 8.4.1.2 Aisle Size and Lot Layout..... 8-7
 - 8.4.1.3 Driveways to Parking Lots..... 8-7
 - 8.4.1.4 Maneuvering Space 8-7

List of Figures

- Figure 8-1. Minimum Street and Access Connection Spacing (Access Management Policy) .. 8-4
- Figure 8-2. Minimum Street and Access Connection Spacing with Roundabouts (Access Management Policy) 8-5
- Figure 8-3. Parking Variables..... 8-6
- Figure 8-4. Parking Lot Layout Dimensions..... 8-8

List of Tables

- Table 8-1. Parking Space Sizes 8-7

CHAPTER 8 - ACCESS CONTROL AND OFF-STREET PARKING

8.1 INTRODUCTION

The purpose of this section is to provide design standards and criteria for access control to commercial, industrial, and multi-family housing properties as well as for the design and construction of commercial driveways, and off-street parking areas.

The information presented in this chapter is in full compliance with the off-street parking requirements of the City's [Zoning Ordinance](#) and [Access Management Policy](#).

8.2 ACCESS CONTROL

8.2.1 Highways

Access to U.S. Highways, State highways, and freeway frontage roads within the City limits requires a permit from the City which must be approved by TxDOT. It is the intent of both the City and TxDOT to minimize access points to highways. Direct access to highways will be strongly discouraged if the property has reasonable access to the City street system.

8.2.2 City Streets

The limitation of access to public streets, especially thoroughfares, is based on the premise that greater accessibility will result in a deterioration in the quality of traffic flow on the through street. Any hindrance to vehicular flow along a roadway detrimentally affects the efficiency and safety of the roadway. Although road users have rights of access to abutting property, they also have the right of minimum interference to travel on the roadway. When conflicts between the two cannot be resolved, preference will be given to the roadway.

8.3 ACCESS DESIGN

8.3.1 Number of Access Points

- To limit the number of access points, joint-access and cross-access serving adjoining parcels must be considered.
 - Developments with multiple destinations must have internal access to one another.
 - Neighboring parcels with driveways that could reasonably be shared (as determined by the City Traffic Engineer or designee) must share access points.
 - Joint and cross access requirements may be waived when, in the City Traffic Engineer's or designee's judgment, such a waiver is warranted.
- The number of connections must be the minimum number necessary to provide reasonable and adequate access to the overall development, as informed by a traffic study, and not the maximum available for the development's frontage.

Detailed requirements can be found in the City's [Access Management Policy](#).

8.3.2 Driveway Design

There are three driveway types used in the City. They are the standard driveway approach, high volume type approach, and the intersection type driveway. These are discussed further in **Chapter 3** of this manual. Guidance on driveway location and design are presented in the driveways section of **Chapter 3** of this manual.

8.3.3 Driveway Spacing

Driveway spacing and connection requirements are provided in the City's [Access Management Policy](#) and vary by street type, as set forth in the [MTP](#). **Figure 8-1**, from the [Access Management Policy](#), provides minimum street and access connection spacing for typical signalized and un-signalized intersections. **Figure 8-2**, from the [Access Management Policy](#), provides minimum street and access connection spacing for roundabout intersections.

Street Type	MTP Target Speed (mph)†	MTP Range of Through Lanes	D Driveway – Driveway Spacing (ft)	I Intersection – Driveway Spacing (ft)	S Signalized Intersection Spacing (ft)	C Street Spacing (ft)	M Median Opening Spacing (ft)
System Link	35 to 45	4 to 6	300	300	1,320	1,000-1,320*	500 - 800
Commercial Connector	30 to 35	2 to 6	250	250	1,000	660-1,000*	500 - 800
Neighborhood Connector	30 to 35	2 to 6	200	250	1,000	660-1,000*	500 - 800
Commerce / Mixed-Use St	25	2 to 4	150	150	600-1,320*	300-660*	NA
Activity Street	25	2 to 4	100**	100**	400-800*	300-660*	NA***
Collector Streets****	25 to 30	2	100‡	100	NA	250	NA
Local Streets****	25	2	75‡	75	NA	250	NA

† Target speed is defined in the MTP as the recommended design speed
 * Refer to text discussion regarding allowable minimums and desirable maximums
 ‡ This does not apply to residential driveways
 ** New driveways on Activity Streets are only allowed if there is not access from a lower class roadway
 *** Median treatments and openings for Activity Streets must be examined on a project- and context-specific basis
 ****Collector/Local Streets: Values shown are for guidance only; closer access spacing may be permitted at the discretion of the City Traffic Engineer or designee.

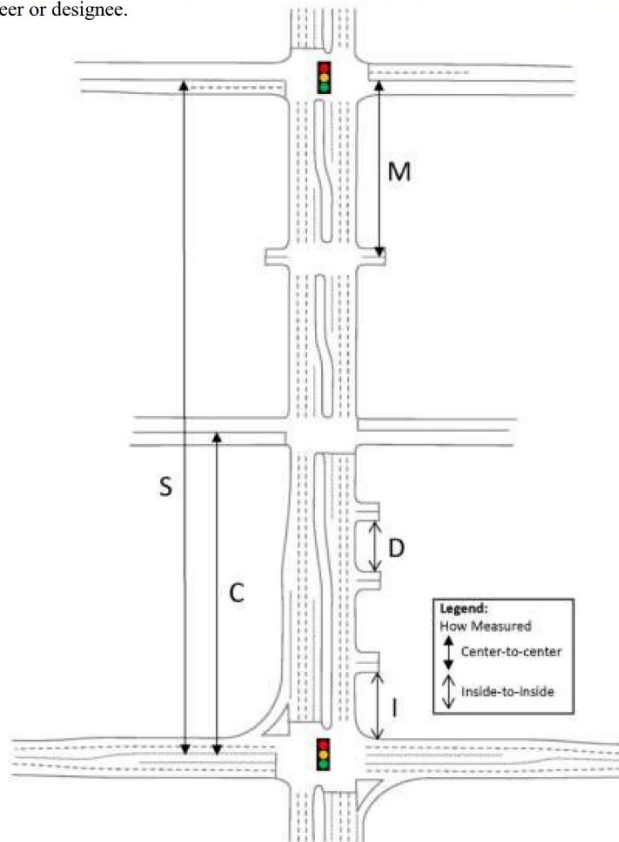

4

Figure 8-1. Minimum Street and Access Connection Spacing (Access Management Policy)

Street Type	MTP Target Speed (mph)†	MTP Range of Through Lanes	I Roundabout – Driveway Spacing (ft)	R Roundabout- Roundabout Spacing (ft)	C Street Spacing (ft)	M Median Opening Spacing (ft)	SR Signal – Roundabout Spacing (ft)
System Link	35 to 45	4 to 6	300	660-1,320*	1,000-1,320*	500 - 800	1,000-1,320*
Commercial Connector	30 to 35	2 to 6	250	660-1,000*	660-1,000*	↓	660-1,000*
Neighborhood Connector	30 to 35	2 to 6	250	660-1,000*	660-1,000*	↓	660-1,000*
Commerce / Mixed-Use St	25	2 to 4	150	300-660*	300-660*	300-800	300-660*
Activity Street	25	2 to 4	100**	300-660*	300-660*	300-800	300-660*
Collector Streets	25 to 30	2	100	250	250	NA	250
Local Streets	25	2	75	250	250	NA	250

† Target speed is defined in the MTP as the recommended design speed

* Refer to text discussion regarding allowable minimums and desirable maximums

** New driveways on Activity Streets are only allowed if there is not access from a lower class roadway

Note: The distances in this table are initial guidelines. Lower values may be acceptable. For all proposed roundabouts, where a driveway (I) is to be constructed within 300 ft or where a connection (R, C, M, SR) is to be constructed within 1,000 feet, a traffic study must be completed to show that the roundabout, driveway, and/or access connection will function acceptably after full-build out plus five years.

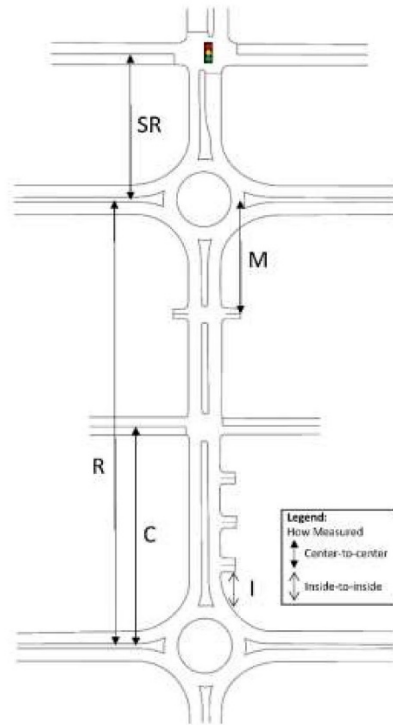

Figure 8-2. Minimum Street and Access Connection Spacing with Roundabouts (Access Management Policy)

8.4 PARKING LOT DESIGN

The design of off-street parking must consider all design factors that affect street through traffic and provide the most efficient access to and from the street, including internal movement, maneuvering of cars, convenience of patrons, security of vehicles, and safety.

The requirements provided in the following paragraphs have been developed to provide for the successful accomplishment of these goals. All driveways and off-street parking facilities shall be designed and constructed in accordance with these principles. **Figure 8-3** shows the different parking variables.

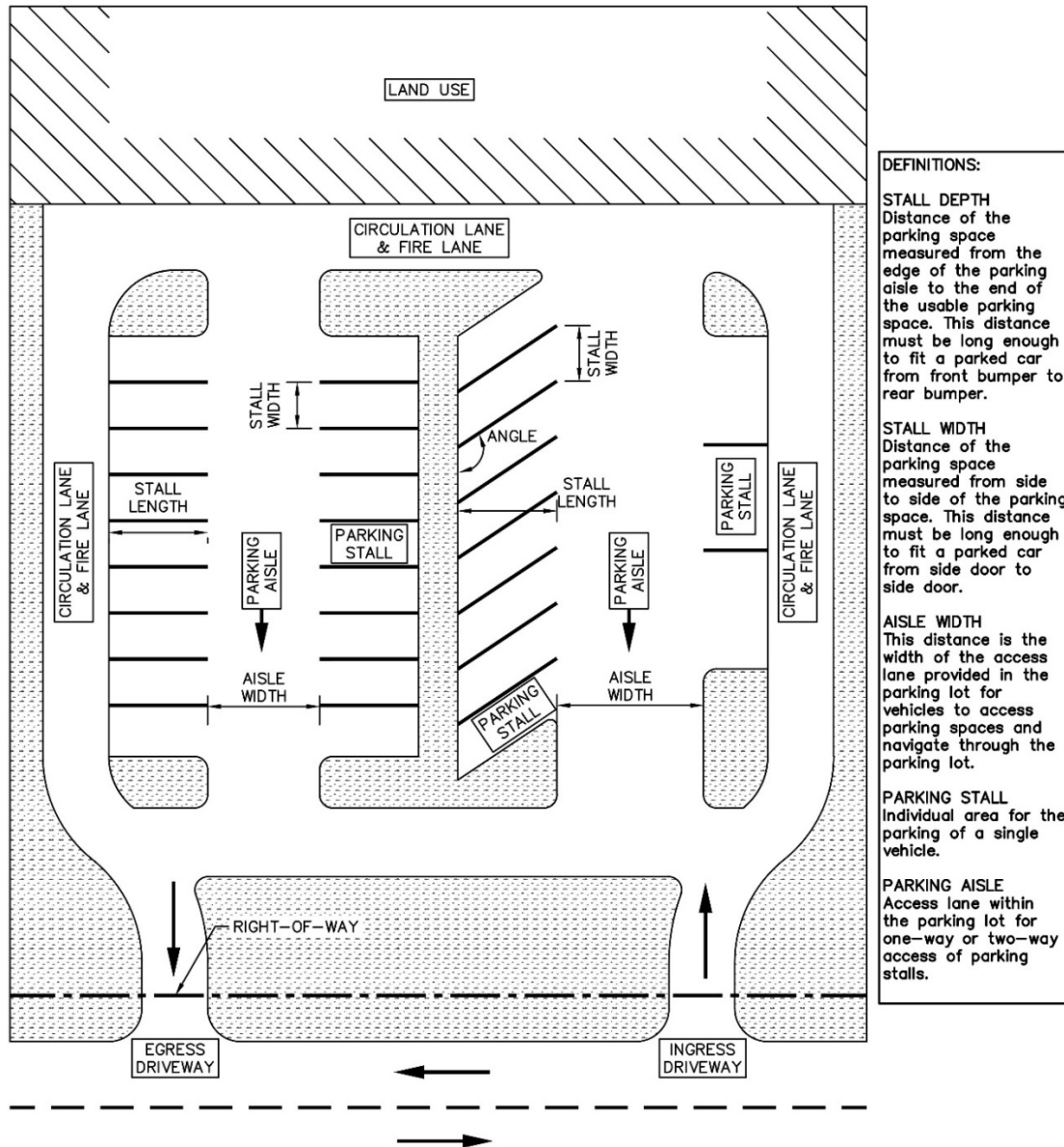

Figure 8-3. Parking Variables

8.4.1 Design Guidelines

The City’s [Zoning Ordinance](#) sets forth requirements for the number of parking spaces based on land use, standard parking space sizes, and the proper layout for various angles of parking stalls. These requirements are summarized in the following sections.

8.4.1.1 Space Size

The required minimum parking stall sizes are summarized in **Table 8-1**.

Table 8-1. Parking Space Sizes

Type	Width	Length
Standard Parking Space	9 feet	18 feet*
Parallel Parking Space	8 feet	22 feet*

*Parking spaces adjacent to landscape areas may project into the landscape area and be reduced to 16 feet in length when separated from the landscape area by curbing or approved wheel stops.

8.4.1.2 Aisle Size and Lot Layout

The requirements for the minimum width of parking stalls plus the aisle are illustrated in **Figure 8-4**. This applies to a single row of head-in parking or two rows of head-in parking sharing an aisle.

8.4.1.3 Driveways to Parking Lots

- When non-residential driveways are less than 20 feet in width, marked separate entrances and exits shall be provided so that traffic shall flow in one direction only.
- Entrances and exits to an alley may be provided if prior approval is obtained in writing from the TPW Department.
- The location of ingress and egress driveways shall be subject to approval of the City’s Traffic Engineer under curb cut or laid down curb permit procedures.
- Except for Unified Residential development, driveways designated as fire lanes shall meet the standards of the Fire Code.

8.4.1.4 Maneuvering Space

- Maneuvering space shall be located completely off the right-of-way of a public street, place or court, except for on-street parking approved by the City Traffic Engineer.
- Parking areas that would require the use of public right-of-way for maneuvering shall not be acceptable as required off-street parking spaces other than for one- and two-family dwellings, except for on-street parking approved by the City Traffic Engineer.
- Parking parallel to the curb on a public street shall not be substituted for off-street parking requirements, except as provided for in an MU-1 or MU-2 Mixed-Use District.

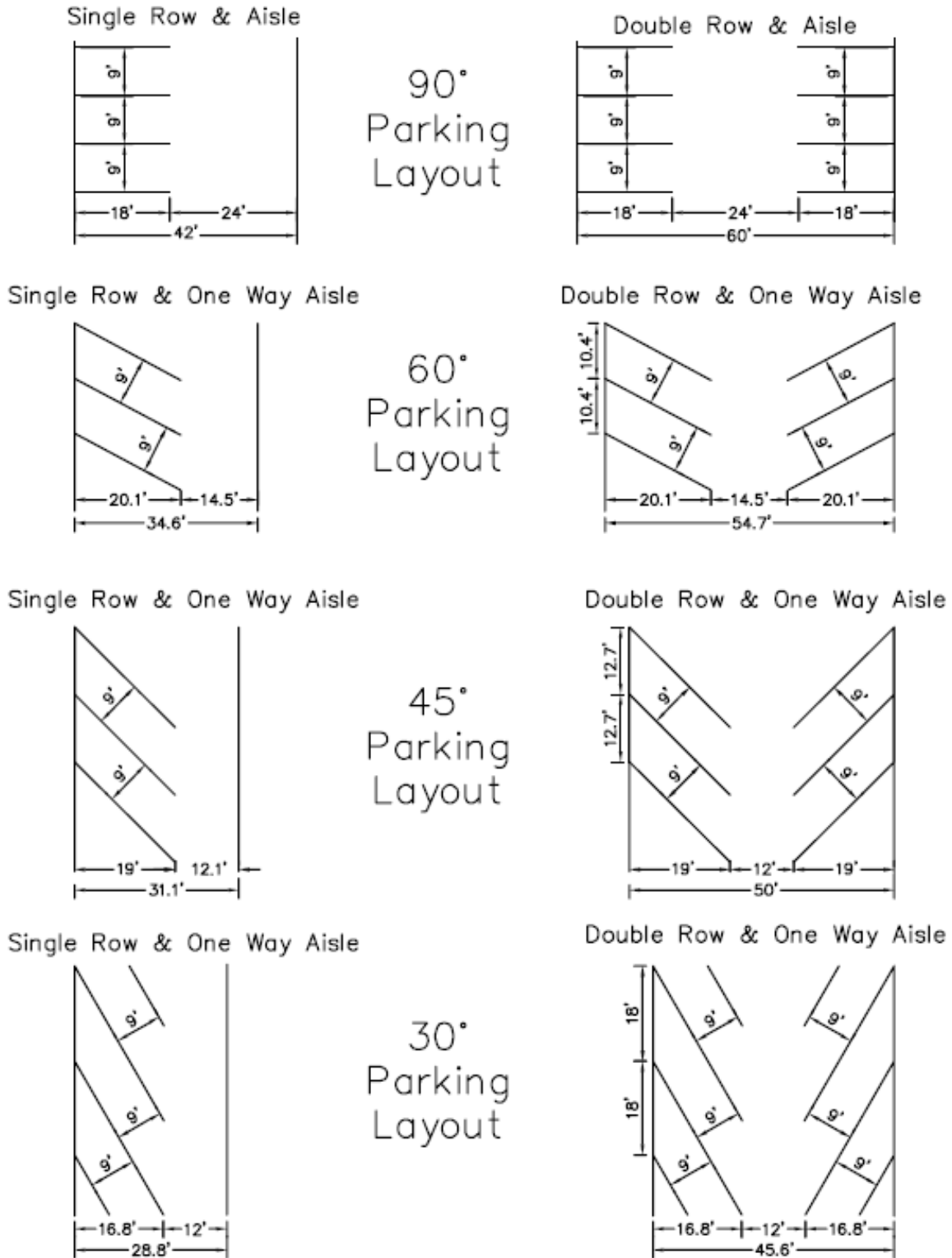

Figure 8-4. Parking Lot Layout Dimensions

Contents

CHAPTER 9 - TRANSIT ACCOMMODATION.....9-2

- 9.1 Introduction..... 9-2
- 9.2 Designing Streets for Transit 9-2
- 9.3 Access to Transit 9-3
- 9.4 Transit Facilities..... 9-4
- 9.5 Bus Stop Placement 9-4
- 9.6 Transit Shelters 9-4
 - 9.6.1 Overview 9-4
 - 9.6.2 Considerations 9-4
 - 9.6.3 Guidance..... 9-4
- 9.7 Transit Stop Accessibility 9-5
- 9.8 Transit-Specific Streetscape Elements 9-5
- 9.9 Transit Priority 9-5
- 9.10 Bicycle Access and Parking..... 9-6
 - 9.10.1 Shared Bicycle/Transit Lanes..... 9-6
 - 9.10.1.1 Considerations..... 9-7
 - 9.10.1.2 Design Guidance 9-8
 - 9.10.2 Off-Street Separated Bike Lanes at Transit Stops 9-8
 - 9.10.2.1 Considerations..... 9-8
 - 9.10.2.2 Guidance 9-8
 - 9.10.3 Bike Parking in Transit Corridors..... 9-10
 - 9.10.3.1 Considerations..... 9-10
- 9.11 Accommodating Rail, BRT and Paratransit..... 9-10
 - 9.11.1 Commuter Rail 9-10
 - 9.11.2 Bus Rapid Transit (BRT) 9-10
 - 9.11.3 Paratransit..... 9-10

List of Figures

- Figure 9-1. Overview of Shared Bicycle/Transit Lanes..... 9-7
- Figure 9-2. Example Separated Bike Lane at Transit Stop..... 9-9

List of Tables

N/A

CHAPTER 9 - TRANSIT ACCOMMODATION

9.1 INTRODUCTION

Transit is a critical aspect of transportation. Many people rely on public transit to access their jobs, school, shopping, recreation and other day to day activities. A better transit system also helps reduce the number of vehicles on roadways and can have significant cost savings. To provide optimal service, transit routes and stops should be conveniently located and easily accessed. This chapter provides an overview of guidelines to consider when designing for transit facilities.

The main types of transit services that run through many cities and premium services for future expansion and investment according to Trinity Metro's [Transit Master Plan](#) include the following:

- Regular bus
- Rapid Bus
- Bus Rapid Transit (BRT)
- Commuter Rail
- Paratransit
- Light Rail
- Streetcar/Core Area Circulation

9.2 DESIGNING STREETS FOR TRANSIT

Transit service can be more efficient, effective, and safe when surrounding land uses and the street network are designed with transit in mind. Automobile lanes as defined in the [MTP](#) were sized to accommodate transit buses, so general transit routes can run on any thoroughfare. However, every street type has cross-sections that allow for special transit lanes. Trinity Metro's [Transit Master Plan](#) includes a Transit Priority Corridor Map that highlights special transit facilities in the City including dedicated transit lanes, peak-hour transit lanes, and transit medians.

Dedicated transit lanes are reserved for exclusive, continuous use by transit vehicles all day. However, when bus traffic is infrequent, they can also be potentially available for use by bicyclists, since bus operators are professional drivers who can be trained to safely share the lane with bicyclists. All five street types include sections with dedicated transit lanes. Dedicated transit lane widths should be based on the [MTP](#).

Peak-hour transit lanes reserve exclusive use by transit when it is needed during certain peak periods of the day. During the remainder of the day, they can be used for on-street parking. Only Activity Streets and Commerce/Mixed-Use Streets include this section element because they are the only street types that allow on-street parking. These lanes cannot have bulbouts or tree wells since the lane must be continuously traversable by transit vehicles during peak periods.

As described in the [MTP](#), transit medians should be sized to accommodate one transit vehicle in each direction. They are intended to accommodate either dedicated bus lanes or center-running

light transit. Additional width is included on both outside edges of these medians for potential passenger platform areas and to accommodate left-turn lanes at intersections. This results in a total width of 34 feet with 10 feet of additional width on either side. Transit medians are included as options on Neighborhood Connectors and System Links because these street types offer the needed width and generally have the level of access management needed to promote high-capacity transit usage of the median.

Principles to consider when designing streets for transit include:

- Transit improvements must be considered as a modal priority on city streets along transit corridors.
- Designated bus lanes should be provided for the busiest transit lines.
- Transit stops should be easily accessible through safe and convenient crossing locations and provide shade or a shelter to improve visibility and protect riders during adverse weather conditions.
- Transit shelters should not obstruct sight distance.
- Streets that connect neighborhoods to transit facilities should be safe and inviting for pedestrians and bicyclists.
- Zoning codes and development standards should encourage walking and a mix of land uses near transit stations and stops.

9.3 ACCESS TO TRANSIT

Transit access is particularly a problem in the outskirts of the City due to a lower density of land uses, auto-oriented development, and poor pedestrian connections. Pedestrians should have safe, accessible, and convenient access to all transit stops. Improvements to provide access should be coordinated with Trinity Metro. Impediments to access include, but not limited to, the following:

- Poor visibility or non-existent crosswalks.
- High speed/volume traffic.
- Non-existent or non-compliant curb ramps.
- Missing sidewalks or sidewalks in poor condition.
- Large distances between crosswalk locations.

Every transit trip should be accommodated with safe, accessible, and convenient street crossings. For midblock crossing design, refer to **Chapter 7** of this manual. Existing crossings should be evaluated at every transit stop. If a crossing is inappropriate, mitigation should be provided to either improve the existing crossing or, in cooperation with Trinity Metro, move the transit stop to a safer crossing location. There should not be transit stops without means to safely and conveniently cross the street.

There are multiple options for accessing transit and addressing the “first-mile/last-mile” challenge in the City including installing sidewalks, dedicated bike lanes, bike share stations, and partnering with transportation network companies (such as Uber and Lyft) or other microtransit programs.

9.4 TRANSIT FACILITIES

If transit facilities are to be included, defer to Trinity Metro for guidance. If transit facilities are designed as part of a development, it shall be done in accordance with Trinity Metro.

9.5 BUS STOP PLACEMENT

New bus stops should be located conveniently near riders’ destinations. Creating more bus stops reduces walking distances but can slow down service. The number of bus stops is a contributor of slow service. The number and location of bus stops are key to balancing passenger needs for convenience and speed, though it has been shown that passengers prefer faster service to shorter walks. To achieve a better balance for greater travel time savings, bus stops should be consolidated. According to Trinity Metro’s [Transit Master Plan](#), on average, it takes a bus about 20 seconds to slow down, stop and pick up a passenger, and accelerate back up to speed. Thus, a consolidation from eight stops per mile to five can save one minute per mile, or five minutes on a five-mile trip. It also provides a more comfortable ride, as it reduces stop-and-go operation. Consolidating stops will not require additional resources, and in some cases, could produce operating cost savings. In addition to transit operation considerations, existing right-of-way and street context considerations also apply. Ultimately, Trinity Metro and the City should work together to determine the most effective placement and number of bus stops.

9.6 TRANSIT SHELTERS

9.6.1 Overview

Transit shelters increase both the comfort and visibility of transit stops by providing shelter from sun, rain and other weather. Shelters typically, though not always, provide additional seating and lighting at a transit stop adding comfort and convenience for riders. Especially in Texas, shade is a critical element to provide comfort to people waiting at transit stops.

9.6.2 Considerations

- The location of transit shelters must minimize obstruction of sight lines.
- Transit stops with passenger activity high enough to warrant a shelter should also provide bike racks.

9.6.3 Guidance

- Shelters must not impede pedestrian flow on the sidewalk. A minimum 6-foot clear Pedestrian Zone must be maintained.
- Stops should have adequate right-of-way to accommodate a shelter and the required Pedestrian Zone width. Shelters are also considered for locations near designated activity centers and locations serving multiple routes or transfers.

- The following requirements must be met before a shelter can be considered for a proposed development:
 - Right-of-way is available.
 - Adjacent property owner approval should be obtained prior to placement.

9.7 TRANSIT STOP ACCESSIBILITY

Transit stops should have the following characteristics:

- Tactile or visual clues should be provided on where to wait for the transit vehicle.
- Any amenities for the stop should not block path of travel on the sidewalk.
- There should be an ease of access between the transit stop and the vehicle.

All transit stops must be designed in accordance with the latest Trinity Metro guidelines, [TAS](#), and [PROWAG](#). Below are a few requirements and guidelines:

- All transit stops must be connected by an accessible route.
- Locating transit stops at signalized intersections is preferred since it improves access for pedestrians with disabilities.
- Crosswalks must be accessible.

9.8 TRANSIT-SPECIFIC STREETScape ELEMENTS

The most important streetscape elements for transit include signs, shelters, seating, trash receptacles, and transit information such as a route map and schedule. All streetscape elements must comply with [TAS](#) and [PROWAG](#). Impacts to the Pedestrian Zone should also be considered.

Incorporating green infrastructure into the transit street design can help improve water quality, manage stormwater runoff, improve aesthetics, calm traffic, and enhance comfort. Green infrastructure can be integrated into sidewalks, medians, and other features. Refer to **Chapter 10** of this manual for specific green infrastructure treatments.

9.9 TRANSIT PRIORITY

Transit service is the most attractive when the time it takes to drive to a location is longer or close to the time it would take riding transit. Transit priority is one option that gives transit a priority over regular traffic by helping transit arrive quicker to a stop. Transit priority helps to improve operations by reducing traffic signal delay for transit vehicles, reducing the need for transit vehicles to stop for traffic at an intersection, reducing transit vehicles' travel time, and improving transit system reliability. Other transit priority approaches, other than the use of dedicated and peak-hour transit lanes as previously discussed, include the following:

- Queue jump lanes – Take up a short stretch of curbside parking for a curbside bus lane. It allows for buses to jump to the front of the queue at bus stops. These can be applied at near-

side (with prohibited right-turns or permitted right-turns-on-red only for vehicular traffic) and far-side stops.

- Transit signal priority – Extends or initiates the green indication earlier when a bus is detected to approach the intersection. This allows buses to pass through the intersection before the signal indication turns red. For near-side pull-out stops, the bus should complete loading before being detected by the signal. At far-side stops, the bus receives the priority signal before entering the stop.

Transit signal priority and queue jump lanes should ideally be applied to signalized streets with low or moderate bus frequencies, high peak hour automobile volumes with low right-turn volumes, and where transit operates in the right lane. Disadvantages of these transit priority approaches include increased delay for automobile traffic on high-volume roadways and the potential negative impact to right-turn movements.

9.10 BICYCLE ACCESS AND PARKING

Connecting bicycle riders with transit routes greatly expands the area that transit serves. Bicycle access can be improved with on-street designated bike lanes or trails leading to transit stops and bike parking at transit stops. The City has a bike-share program that people can use to connect to transit facilities. The program has stations within the central City. The location of these stations and the location of transit stops should complement each other to provide for more convenient connections between different modes. The following sections provide guidance on the implementation of shared bicycle/transit lanes, off-street separated bike lanes at transit stops, and bike parking in transit corridors. Refer to **Chapter 4** of this manual for additional guidance on bicycle parking and bicycle lane widths near transit stops.

9.10.1 Shared Bicycle/Transit Lanes

Under certain circumstances, a shared lane reserved for transit vehicles and bicyclists can provide much improved accommodation for both traveler groups; however, they are not ideal for bicyclists or transit vehicles, especially in areas with high volumes. Shared Bicycle/Transit Lanes (SBTLs) provide basic bicycle access on transit streets where no space is available for dedicated bikeways. SBTLs are specifically designed to provide room for the two users to maneuver together as transit vehicles start and proceed again along a corridor. Shared lanes are commonly also used to accommodate right-turning vehicles. Right-turn use, along with use by both transit vehicles and bicycles can reduce the level of service for all users. **Figure 9-1** shows an overview of a shared bicycle/transit lane.

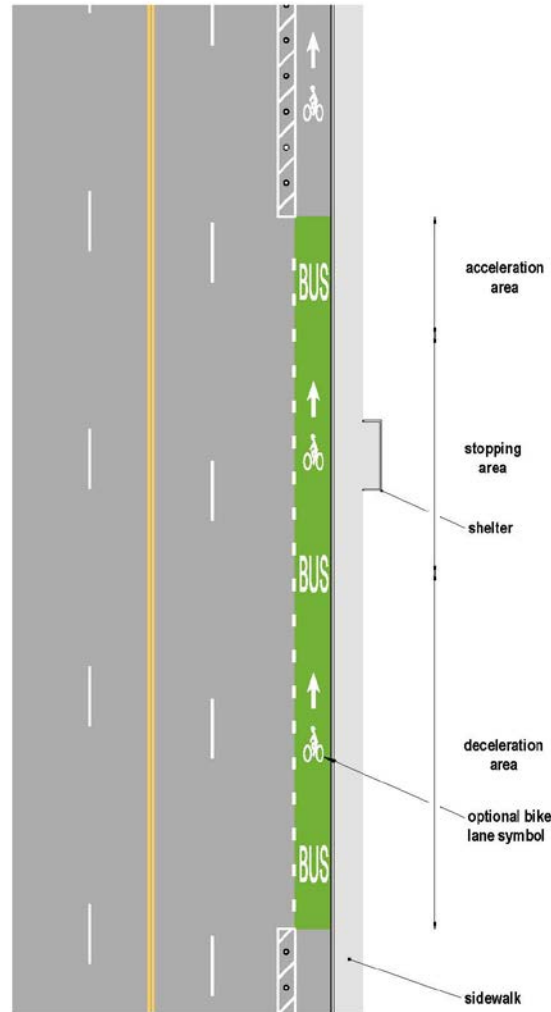

Figure 9-1. Overview of Shared Bicycle/Transit Lanes

9.10.1.1 Considerations

- Bicycle volumes, transit frequency, available right-of-way, total cross section, frequency of transit stops, and temporal changes in street operation should be considered in determining the appropriateness of a shared bicycle/transit lane.
- Shared bicycle/transit lanes are not appropriate on rush hour restricted streets (streets where the curb parking lane converts to a travel lane during peak hours).
- Transit operators should be trained in how to interact with bicyclists in shared bicycle/transit lane facilities.
- Typically, shared bicycle/transit lanes should not be used on any street with a posted speed limit above 30 mph and headways less than four minutes.
- Vehicles using shared bicycle/transit lanes for through travel can be a major issue. This not only degrades performance but introduces serious safety concerns. Education and enforcement are always necessary for ensuring compliance when implementing shared bicycle/transit lanes.

9.10.1.2 *Design Guidance*

- Shared bicycle/transit lanes should be in the outermost lane, ideally adjacent to the curb. Bicycle/transit lanes may be located adjacent to curbside parking; however, this introduces substantial conflict and degrades operations and safety in the priority lane.
- Shared bicycle/transit lanes should have sufficient width for dual bicycle/transit use. 16 feet is preferred to permit vehicles and bicyclists to pass one another comfortably within the priority lane. The minimum width of shared bicycle/transit lanes is 13 feet (inclusive of the gutter pan).
- Shared bicycle/transit lanes typically are not physically separated from adjacent travel lanes.
- Signage permitting only buses and bicycles should be used.

9.10.2 **Off-Street Separated Bike Lanes at Transit Stops**

Bike lanes that are physically separated can be integrated with a variety of transit stop designs. They are compatible with mid-block, near-side and far-side transit stop locations. Where feasible, separated bike lanes should be routed behind transit stops to eliminate conflicts between buses and bicyclists. This recommended configuration—referred to as a “floating transit stop”—repurposes the street buffer into a dedicated passenger platform between the motor vehicle lane and the bike lane. Refer to **Chapter 4** of this manual for the implementation of separated bicycle lanes at other locations.

9.10.2.1 *Considerations*

- Guide transit passengers across the bike lane at clearly marked locations. Two pedestrian crossings are recommended, but not required. Channelizing railings, planters or other treatments can be used to help direct pedestrians, particularly those with vision disabilities, to the crossing locations. Transit stop leaning rails or bicycle lean rails can serve the dual purpose of serving as a channelizing tool for pedestrians while also serving as a station amenity or bicycle facility amenity.
- Provide clear direction to bicyclists when they are expected to yield to pedestrians crossing the bike lane at transit stops.
- Consider in-lane transit stops to preserve space for the street buffer, maintain separated bike lane width, and simplify bus re-entry into traffic. Where on-street parking is present, a curb extension is required to provide an in-lane stop.
- Consider raised crossings across roadways if a near-side transit stop diminishes motorist approach sight distance or increases the effective turning radius for motor vehicles.

9.10.2.2 *Guidance*

- Provide clear sight lines between pedestrians and bicyclists at expected crossing locations.
- Provide level landings at all locations where pedestrians are required to turn in accordance with pedestrian accessibility guidelines.
- Preserve a minimum 5-foot by 8-foot clear boarding and alighting area that connects to a pedestrian access route. Advanced lateral deflection of the bike lane may be necessary to accommodate the boarding and alighting area.

- In constrained situations, or to provide level pedestrian crossings, transition the bike lane to sidewalk level. Locate bicycle transition ramps near crosswalks and outside of any lateral shift of the bike lane.
- Place railings or planters (3 feet maximum height) at the back of the platform for high ridership stops or along two-way separated bike lanes to channelize pedestrians to designated crossings. Ends of railings should be flared inward toward the transit stop and away from the bike lane for a safer bicycling environment.
- Where the street buffer is less than 8 feet, taper the bike lane to create space for the transit stop.
- Maintain an appropriate sidewalk width, which is typically wider than the minimum pedestrian access route.
- If necessary, narrow the bike lane along the transit stop to maintain an accessible sidewalk and transit stop in constrained areas. Where narrowed to 4 feet, elevate the bike lane to intermediate or sidewalk level to minimize pedal strike risks on curbs. In the case of two-way facilities, a minimum width of 8 feet should be used.
- The contraflow direction of bicycle travel in a two-way separated bike lane (or a side path) introduces a potentially unexpected bicycle movement for transit passengers. Provide a solid yellow line to discourage passing movements along the transit stop, and clearly delineate direction of travel and yielding responsibilities.

Figure 9-2 shows an example of a separated bike lane at a transit stop.

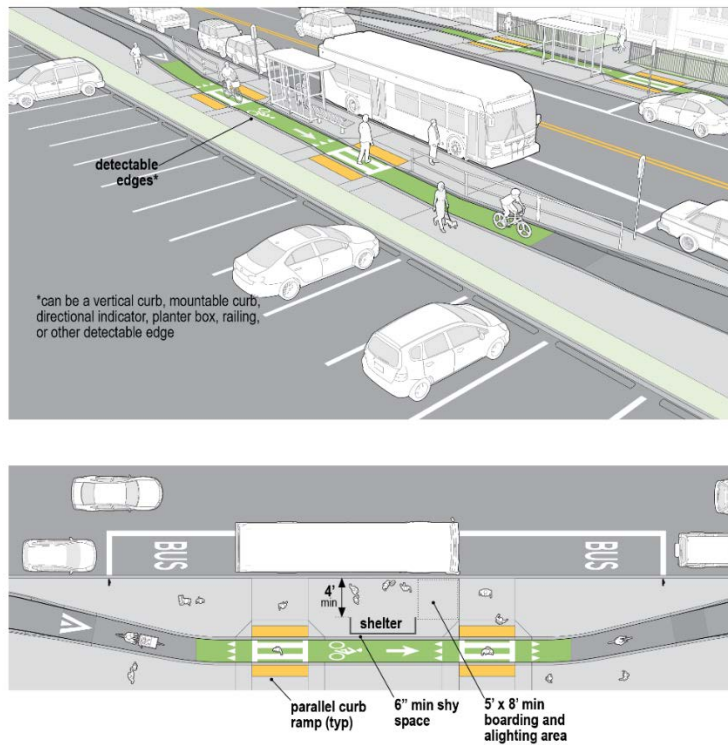

Figure 9-2. Example Separated Bike Lane at Transit Stop

9.10.3 Bike Parking in Transit Corridors

Refer to **Chapter 4** of this manual for information on on-street and off-street bicycle parking.

9.10.3.1 Considerations

- Locate adjacent to transit stops. Bike racks increase the catchment area of transit stops, providing a longer range and faster first- and last-mile connection compared to walking.
- Locate outside of the accessible path of travel, as well as outside of the bus stop zone encompassing the landing area and clear zone, and the area in between.
- Ensure easy and unobstructed access to bike racks.
- Ensure the visibility of bike racks, including non-restricted views from landscaping, shelters, or walls and under adequate street lighting for security.
- Consider covered or weather protected locations as an added benefit to bicyclists.
- At floating bus stops, place at the sidewalk edge, to function as a barrier to discourage riders and pedestrians from crossing into the bike lane, except at the designated crossing.

9.11 ACCOMMODATING RAIL, BRT AND PARATRANSIT

9.11.1 Commuter Rail

Trinity Metro offers two commuter rail options: TEXRail and the Trinity Railway Express. TEXRail service, a commuter rail line, goes from downtown Fort Worth, across northeast Tarrant County, through North Richland Hills and Grapevine and into the DFW International Airport. The Trinity Railway Express (TRE) is a commuter rail service between downtown Fort Worth and downtown Dallas. To accommodate for commuter rail, it is important to have Transit-Oriented Development (TOD) around rail stations to enhance the areas around the stations in ways that will improve and encourage ridership including plans for long-term transitioning of adjoining park and ride facilities into mixed use, walkable development.

9.11.2 Bus Rapid Transit (BRT)

BRT is a frequent, fast bus service featuring special vehicles, transit signal priority, exclusive travel lanes, level boarding, pre-paid fare collection, and unique branding. These premium bus services that are faster, more reliable, and more easily identifiable make bus service much more attractive and can increase ridership. BRT provides light rail-like service without the high costs associated with rail infrastructure. When operating in mixed traffic, the speed of the transit should be adjusted to reduce hazards for pedestrians and bicyclists. According to Trinity Metro's [Transit Master Plan](#) and the [MTP](#), Trinity Metro hopes to invest more in these types of services in the future.

9.11.3 Paratransit

Trinity Metro's ACCESS paratransit service offers door-to-door transportation for persons with a disability that prevents them from riding regular City bus service. As the City continues to expand other transit services to reach farther areas, it is important to continue to expand paratransit services as well to provide more connections for persons with disabilities.

Contents

CHAPTER 10 -STREETSCAPE ECOSYSTEM.....10-2

- 10.1 Introduction10-2
- 10.2 Stormwater Management.....10-2
 - 10.2.1 Planters10-2
 - 10.2.1.1 Considerations10-2
 - 10.2.1.2 Guidance.....10-2
 - 10.2.2 Swales10-3
 - 10.2.2.1 Considerations10-3
 - 10.2.2.2 Guidance.....10-3
 - 10.2.3 Curb Extensions10-3
 - 10.2.3.1 Considerations10-3
 - 10.2.3.2 Guidance.....10-4
- 10.3 Urban Forestry10-4
 - 10.3.1 Considerations.....10-4
 - 10.3.2 Guidance10-5

List of Figures

N/A

List of Tables

N/A

This Chapter will be published at a future date.

Contents

CHAPTER 11 - PROCEDURAL POLICIES11-2

- 11.1 Street Closure Policy11-2
 - 11.1.1 Temporary Street Closure for Purposes Other than Construction and/or Maintenance.....11-2
 - 11.1.2 Temporary Street Closure of Local (Residential) Streets for Construction and/or Maintenance.....11-2
 - 11.1.2.1 From 0-8 Hours During a Normal Workday11-2
 - 11.1.2.2 From 8-240 Hours (10 Calendar Days).....11-2
 - 11.1.3 Local (Residential) Streets to be Closed More Than 10 Calendar Days11-2
 - 11.1.4 Collector and Thoroughfares to be Closed Fewer than 10 Calendar Days 11-3
 - 11.1.5 Collector and Thoroughfares to be Closed More Than 10 Calendar Days. 11-3
 - 11.1.6 Supplementary Notification Procedures 11-3
 - 11.1.6.1 Local (Residential) Streets.....11-3
 - 11.1.6.2 Collector and Thoroughfares11-4
 - 11.1.7 Barricading 11-4
 - 11.1.8 Street Classifications11-4
- 11.2 Restricted Parking on Residential Streets11-4
 - 11.2.1 Removal of Parking for Entire Block Face.....11-4
 - 11.2.2 Removal of Parking for less than Entire Block Face 11-4
- 11.3 Temporary Use of Parking Meter Space.....11-5
 - 11.3.1 Authority 11-5
 - 11.3.2 Meter Rental/Bagging Requests and Fees.....11-5
 - 11.3.3 Waiver of Fees 11-5
 - 11.3.4 Payment11-6
 - 11.3.5 Meter Rental/Bagging Procedure 11-6

List of Figures

N/A

List of Tables

N/A

CHAPTER 11 - PROCEDURAL POLICIES

11.1 STREET CLOSURE POLICY

The City Council has authorized the Director of TPW to review requests for the temporary closure of streets and to grant such requests in accordance with the guidelines in the following paragraphs. The authority to close the street will be granted only after all other options are exhausted. This policy shall in no way prevent the City or any other authorized agency from the emergency closing of a public street, highway, or any other public way for the protection of life and or property. Sidewalk and bike lane closures shall be done in accordance with the [TMUTCD](#).

11.1.1 Temporary Street Closure for Purposes Other than Construction and/or Maintenance

Requests for temporary street closures for periods not exceeding three City working days in duration shall be made at least three City working days prior to the requested date of closing so that affected departments may review the request for approval or disapproval (no exceptions). Only those temporary street closings or lane closings which will not unreasonably interfere with normal traffic operations and fire or police emergency vehicle routes shall be permitted.

Closures for schools, churches, civic associations, fraternal organizations, charitable and other nonprofit organizations, including professional, business and trade associations may be permitted upon making a request to the Director of TPW and obtaining proper approval to temporarily close streets. Closures for pop-up street projects or outdoor public events should follow any additional guidelines and requirements stated in the [Pop-Up Projects Guide](#) and [outdoor public events policy](#) respectively.

When the temporary closing of a street is requested by individuals or organizations other than those listed in the preceding paragraph, or when the street closing is for a longer time than that permitted under this policy, the request shall be submitted to the City Council for their review and approval. Sufficient lead time (typically four to six weeks) must be provided for the request to be reviewed and placed on the agenda of the City Council meeting.

11.1.2 Temporary Street Closure of Local (Residential) Streets for Construction and/or Maintenance

11.1.2.1 *From 0-8 Hours During a Normal Workday*

The City's Field Supervision personnel (Maintenance Foreman, General Foreman, Construction Inspector, etc.) may authorize temporary street closures not to exceed four hours of a normal workday.

11.1.2.2 *From 8-240 Hours (10 Calendar Days)*

The Director of TPW, or his/her designated representative, may authorize temporary street closures, not to exceed 240 hours (10 days), after proper notification has been made.

11.1.3 Local (Residential) Streets to be Closed More Than 10 Calendar Days

All local streets to be closed more than 10 calendar days for any purpose must be approved by the City Council. Sufficient lead time must be provided for the request to be placed on the agenda of the City Council meeting. After the closure is approved by the City Council, the Director of TPW

or his/her designated representative shall contact all emergency and service organizations to assure they are properly notified.

11.1.4 Collector and Thoroughfares to be Closed Fewer than 10 Calendar Days

Requests to close collector and thoroughfares for construction and/or maintenance purposes for 10 days or less must be submitted to the Director of TPW, or his/her designated representative, at least three working days prior to the actual street closure. If the Director of TPW finds it necessary to close the street, the following procedures must be followed.

- An approved detour traffic route shall be provided for the closure. The detour route must be properly signed and marked. Omission of a detour route will not be permitted on collector and thoroughfares unless waived in writing by the Director of TPW or his/her designated representative.
- The Director of TPW, or his/her designated representative, shall contact all emergency and service organizations in cases involving collector and thoroughfares to verify that they have been properly notified.

11.1.5 Collector and Thoroughfares to be Closed More Than 10 Calendar Days

- All collector and thoroughfares to be closed more than 10 calendar days must be approved by the City Council. Sufficient lead time must be provided for the request to be placed on the agenda of the City Council meeting.
- Notification, detour, and barricading procedures are the same as collector and thoroughfares to be closed fewer than 10 calendar days.
- Collector and thoroughfares shall not be closed other than for construction and maintenance purposes, without the approval of the City Council, except in cases of emergency which will be determined by the Chief of Police or another authorized City official.

11.1.6 Supplementary Notification Procedures

11.1.6.1 Local (Residential) Streets

Local (residential) streets to be closed four hours or fewer that have been authorized by a City Field Supervisor may be closed after notifying the Police Department and Fire Department without notifying other agencies such as the Trinity Metro, TPW, etc., provided that other access to the area is available and unless the Field Supervisor feels that additional notification would assist the flow of traffic, avoid confusion, avoid citizen complaints, or otherwise make the job easier in the field.

Local (residential) streets to be closed for more than four hours shall be closed only after the following organizations have been notified by the person(s) authorizing the closure:

- Fire Department
- Police Department
- Med-Star
- Police Traffic Office
- Trinity Metro
- TPW
- Street Division Office

11.1.6.2 *Collector and Thoroughfares*

At least three working days prior to the actual street closure, a list of proposed streets to be closed must be submitted to the Director of TPW or his/her designated representative. The list must include the location of the actual street closure, date and length of closure, how barricading will be handled and by whom, phone number and person to contact should there be a question, why the closure is necessary, name of insurance company who will be indemnifying the City, contractor's name, license number and/or bond numbers.

At the time the TPW Department receives the list of closures, the list of organizations below must be notified, preferably by providing them with a copy of the same information submitted to the Director of TPW.

- Fire Department
- Police Department
- Med-Star
- Police Traffic Office
- Trinity Metro
- TPW
- Street Division Office

11.1.7 **Barricading**

Barricading of all streets shall be handled in accordance with the type of closure being made. The [TMUTCD](#) and instructions from the Director of TPW shall be followed.

11.1.8 **Street Classifications**

Street classifications shall be in accordance with definitions provided in the City's [MTP](#). For purposes of this policy, the Director of TPW shall have the sole authority in determining when a section of street is functioning as a local, collector, or thoroughfare.

11.2 **RESTRICTED PARKING ON RESIDENTIAL STREETS**

The following paragraphs contain the policy for permanently removing parking from residential streets. This policy shall in no way alter the power or authority of the City Traffic Engineer in the control of traffic and parking for the safe and efficient movement of traffic.

11.2.1 **Removal of Parking for Entire Block Face**

The removal of parking on residential streets will be considered when a petition is signed by two-thirds of the property owners, or residents, on the side of the street where parking is to be removed for the entire length of the block.

11.2.2 **Removal of Parking for less than Entire Block Face**

Removal of parking, when requested on individual lot frontages, will be considered in unusual situations when a petition is signed by two-thirds of the property owners, or residents, on the side of the block where parking is to be removed.

11.3 TEMPORARY USE OF PARKING METER SPACE

The Permit Center of the Planning and Development Department handles all requests for rental/bagging of parking meter spaces including those requests resulting from the construction or remodeling of a building. Requests resulting from these building activities, and which require a building permit, are handled by the Permit Center of the Planning and Development Department. The following paragraphs describe the administrative procedures used in processing requests for parking meter rental/bagging. The actual bagging and unbagging of meters is done by Parking Services based on parking meter permits delivered by the Permit Center or by Parking Services for special events.

11.3.1 Authority

- The City Traffic Engineer, or duly authorized designee (Parking Manager), is authorized to install or place parking meters at the established parking meter rates. Each parking meter shall be placed upon the curb alongside of or next to an individual parking space; such space to be designated as hereinafter provided.
- The City Traffic Engineer, or employee above referred to, shall provide for the installation, regulation, control, operation and use of the parking meters provided for in this article and shall maintain such meters in good operating condition. Parking meters shall be capable of being operated, either automatically or mechanically, upon the deposit therein of a designated coin or coins of United States currency, for the full period of time for which parking is lawfully permitted at any of the established parking meter rates.

11.3.2 Meter Rental/Bagging Requests and Fees

When it is deemed necessary to rent/bag meters relating to construction work being performed in the street, sidewalk, or adjacent property, an initial permit fee per metered space per day shall be required. On certain occasions, it may become necessary for a contractor working in the street or on the sidewalk to utilize unmetered curb space that has been designated “Time Limit parking” or “No Parking”. When this occurs, the City Traffic Engineer is empowered to authorize temporary use of such space based on encroachment fee structure. In addition, when a commercial firm or other organization shows a reasonable need for renting/bagging metered parking spaces for non-advertising purposes and non-construction type work like special events, the City Traffic Engineer is empowered to authorize such rentals, and an initial permit fee per metered space per day shall be required. An expedited fee is also required under a certain turnaround time. All requirements and fees for meter rentals/bagging can be found on the City’s [webpage](#).

11.3.3 Waiver of Fees

When City crews or contractors employed by the City must do work in the street that requires the parking to be temporarily removed, the City Traffic Engineer or his designated representative may authorize the waiver of the initial permit fee and/or meter rental/bagging fee (the general rule is four spaces, anything more must go through Council). The decision to temporarily remove parking for this purpose shall be made by the Director of TPW, the City Traffic Engineer, or their designated representatives. This policy shall apply to all utility companies, contractors, private individuals, City crews, and all other types of construction crews not specifically mentioned.

Where the City Traffic Engineer finds such use to be in the public interest and for the general welfare, groups like civic associations, fraternal groups, charitable and other non-profit organizations, including professional and trade associations, may be granted limited use of metered spaces without charge for such purposes as the review of a parade or the movement of out-of-town delegates or visitors to and from a convention or similar special event. **Requests of this type shall be limited to no more than four metered spaces and for periods not exceeding one day at a time.** Applications for more extensive space, or for longer periods of time, shall be referred to the City Council for their decision based on public convenience and welfare.

Where an event is deemed by the City Council to be of sufficient importance to the public to justify the closing of a street for any special event, no charge shall be made for the parking spaces involved.

11.3.4 Payment

- Immediate payment is required by all.
- Firms without established credit will be required to pay in advance.
- The definition of “established credit” is individuals or firms that have had meters rented/bagged in the past and have been faithful in payment.
- The Traffic Engineering Section may determine if an individual or firm is deemed to have established credit.

11.3.5 Meter Rental/Bagging Procedure

- The Parking Management Section has the responsibility of bagging meters for rentals.
- Normal workdays are 8:00 a.m. to 5:00 p.m., Monday through Friday.
- All meter bagging will be completed by 8:30 p.m. the day prior to rental day.
- Upon completion of bagging, meter bags will be removed from all expired rental spaces.

Contents

CHAPTER 12 - TRAFFIC IMPACT ANALYSIS GUIDELINES12-3

- 12.1 Introduction..... 12-3
- 12.2 Responsibility 12-3
- 12.3 Determination of Need..... 12-3
 - 12.3.1 Special Circumstances.....12-4
 - 12.3.2 Study Update12-4
- 12.4 Study Type Requirements 12-4
 - 12.4.1 Methodology Memo Requirements.....12-4
 - 12.4.1.1 Project Information..... 12-4
 - 12.4.1.1 Definition of Study Area 12-4
 - 12.4.1.2 Trip Generation..... 12-5
 - 12.4.1.3 Trip Distribution..... 12-5
 - 12.4.1.4 Projecting Future Volumes and Conditions to be Analyzed 12-6
 - 12.4.1.5 Special Site Related Topics 12-7
 - 12.4.2 TIA Contents12-7
 - 12.4.2.1 Executive Summary 12-7
 - 12.4.2.2 Table of Contents 12-7
 - 12.4.2.3 Introduction..... 12-7
 - 12.4.2.4 Existing and Proposed Site Uses 12-7
 - 12.4.2.5 Existing and Proposed Transportation System..... 12-8
 - 12.4.2.6 Trip Generation..... 12-9
 - 12.4.2.7 Trip Distribution and Traffic Assignment..... 12-10
 - 12.4.2.8 Background Growth Rate..... 12-10
 - 12.4.2.9 Study Scenarios..... 12-10
 - 12.4.2.10 Traffic Operations Analysis 12-10
 - 12.4.2.11 Mitigation 12-12
 - 12.4.2.12 Sight Distance Analysis..... 12-13
 - 12.4.2.13 Auxiliary Lane Analysis 12-14
 - 12.4.2.14 Access Spacing 12-14
 - 12.4.2.15 Conclusions and Recommendations..... 12-14

List of Figures

- Figure 12-1. Trip Distribution Example Exhibit 12-6
- Figure 12-2. Existing Lane Assignment and Traffic Control Example Exhibit..... 12-8
- Figure 12-3. Existing Traffic Volumes Example Exhibit 12-9

List of Tables

- Table 12-1. Study Type and Submittal Requirements 12-3
- Table 12-2. Trip Generation Example Table..... 12-5
- Table 12-3. Trip Generation Rates/Equation Example Table..... 12-10
- Table 12-4. Background Growth Rate Calculation Example Table 12-10



Table 12-5. Intersection Capacity Analysis Example Table 12-11
Table 12-6. Thoroughfare Capacity Analysis Example Table 12-12
Table 12-7. Mitigation Requirements..... 12-13
Table 12-8. Mitigation Example Table 12-13

12

CHAPTER 12 - TRAFFIC IMPACT ANALYSIS GUIDELINES

12.1 INTRODUCTION

The purpose of the Transportation Impact Analysis (TIA) Guidelines is to provide development and transportation consultants with the framework and guidance to prepare TIAs for review by the City. These guidelines also outline the basic information that must be included in a TIA.

12.2 RESPONSIBILITY

When required, the owner shall submit, at the owner’s expense, a TIA that assesses the traffic impacts associated with a proposed development. The study must be prepared under the direction, and signed/sealed by, a licensed professional engineer in the State of Texas.

12.3 DETERMINATION OF NEED

An applicant preparing a zoning request, preliminary plat, or redevelopment project that involves a change in land use must submit a TIA Determination Worksheet to TPW for review. The TIA determination worksheet contains trip generation information and details of the proposed development including project location, land use, and the proposed development intensity.

The latest edition of the Institute of Transportation Engineers (ITE) Trip Generation Manual should be used to determine the number of trips generated by a proposed development in the TIA determination worksheet. Other sources of trip generation publications, e.g. National Cooperative Highway Research Program (NCHRP) Report 684, may be proposed in the TIA determination to TPW, if and only if, the trip generation information is not available in the ITE Trip Generation Manual.

TPW will review the completed TIA determination worksheet. **Table 12-1** shows the study type that will be required based on the total anticipated peak hour site traffic for the proposed development.

Table 12-1. Study Type and Submittal Requirements

Anticipated Trip Generation/Condition	Study Type Required	Submittal Date	
		Zoning Change Requested	No Zoning Change Requested
All Projects	TIA Determination Worksheet	With Zoning Request	Prior to Preliminary Plat
> 500 total peak hour trips	Traffic Impact Analysis (TIA)	At Preliminary Plat*	
> 500 additional peak hour trips from previous project submittal		At Final Plat*	
<i>If TIA is required</i>	<i>Methodology Memo</i>	<i>Prior to TIA submittal</i>	

*At the discretion of TPW, TIAs may be required to be submitted with the Zoning Request to address significant transportation concerns prior to platting.

12.3.1 Special Circumstances

In addition to the trip generation thresholds presented in **Table 12-1**, a TIA may be required under the following conditions:

- The proposed nonresidential development is anticipated to significantly impact residential neighborhoods.
- Traffic operational impacts such as problems with driveways, auxiliary lanes, signal timing, median openings, or sight distance are anticipated. In such cases, the study will only be required to answer the questions related to the specific impacts.
- Existing traffic problems on adjacent streets are expected to worsen due to the anticipated traffic generation from the proposed development.
- The internal street or access system is not anticipated to accommodate the expected traffic generation.
- A TIA may be required at any stage of development at discretion of TPW.

12.3.2 Study Update

A TIA update will be required for any previous TIA relating to a development that is more than two (2) years old, unless TPW determines that conditions of the study area have not changed significantly. The TIA update should include any changes to the proposed development, including land use, intensity, anticipated build out year, etc. and the resulting impacts of the new assumptions.

12.4 STUDY TYPE REQUIREMENTS

This section covers the outline and specific requirements of each TIA type.

12.4.1 Methodology Memo Requirements

A Methodology Memo is required with every project requiring a TIA. To provide consistency and to facilitate staff review of traffic studies, the following sections are required to be included in the Methodology Memo.

12.4.1.1 *Project Information*

The proposed project location, land use, and proposed development intensity should be identified. The proposed development's site access locations and functionality are to be identified. If the project is split into phases, the phasing breakout is to be identified with corresponding build out dates for each phase. Additionally, if a zoning change is requested, a reference to the existing zoning and proposed zoning and/or use being requested should be included.

12.4.1.1 *Definition of Study Area*

The study area intersections and roadways to be analyzed, in addition to the site drives, should be identified. The following outlines the typical study area based on the anticipated trip generation:

- All existing and planned thoroughfare and collector intersections within one (1) mile.
- All existing and planned school sites, transit routes/stops, trails, and bike lanes within one (1) mile.
- When adjacent to a major highway, the study area shall terminate at the furthest frontage road intersection from the site.
- Additional intersections or analysis parameters may be added to the study area at the discretion of TPW.

12.4.1.2 Trip Generation

The proposed development’s daily and peak hour trip generation should be presented as shown in **Table 12-2**. Trip generation rates should be obtained from the latest version of the Institute of Transportation Engineers *Trip Generation Manual*. When determining trip generation, the following factors should be considered:

- Any impacts due to pass-by or internal capture should be included.
- The number of vehicle trips should be adjusted for the number of trips made by alternative transportation modes including pedestrian, bicycle, and transit trips. Sources for number of trips made by alternative transportation modes can include ridership data, pedestrian counts, bicyclist counts, and data from the [National Bicycle and Pedestrian Documentation Project](#).
- If the development is anticipated to have phases, these should be outlined.
- If a zoning change is requested, a comparison of the existing zoning trip generation versus the proposed zoning trip generation is required.

Table 12-2. Trip Generation Example Table

Land Use Description	ITE Code	Intensity / Units	Daily	Peak Hour		
				In	Out	Total
Build Out Base Trips (Before Reductions)						
Shopping Center	820	1,000 SF	#	#	#	#
Single Family	210	Dwelling Units	#	#	#	#
Build Out Internal Trips						
Shopping Center	820	1,000 SF	#	#	#	#
Single Family	210	Dwelling Units	#	#	#	#
Net External Build Out Trips			# - #	# - #	# - #	# - #
Build Out Pass-by Trips						
Shopping Center	820	1,000 SF	#	#	#	#
Net New Build Out Trips			# - # - #	# - # - #	# - # - #	# - # - #

12.4.1.3 Trip Distribution

An estimate of the directional distribution of site traffic entering and exiting the proposed development should be presented. The directional distribution of the development should be based on:

- Existing traffic patterns;

- Proposed site access locations;
- Anticipated local traffic patterns for development; and
- Future study area roadway network (If applicable).

A directional distribution figure should be provided to clearly communicate distribution assumptions for the study area as a whole (global) and at each intersection and access drive (local). The figure should also distinguish between entering and exiting trips. Multiple trip distributions may be needed for phased developments to reflect changing traffic patterns resulting from additional land uses and access points in subsequent phases. **Figure 12-1** for an example trip distribution exhibit.

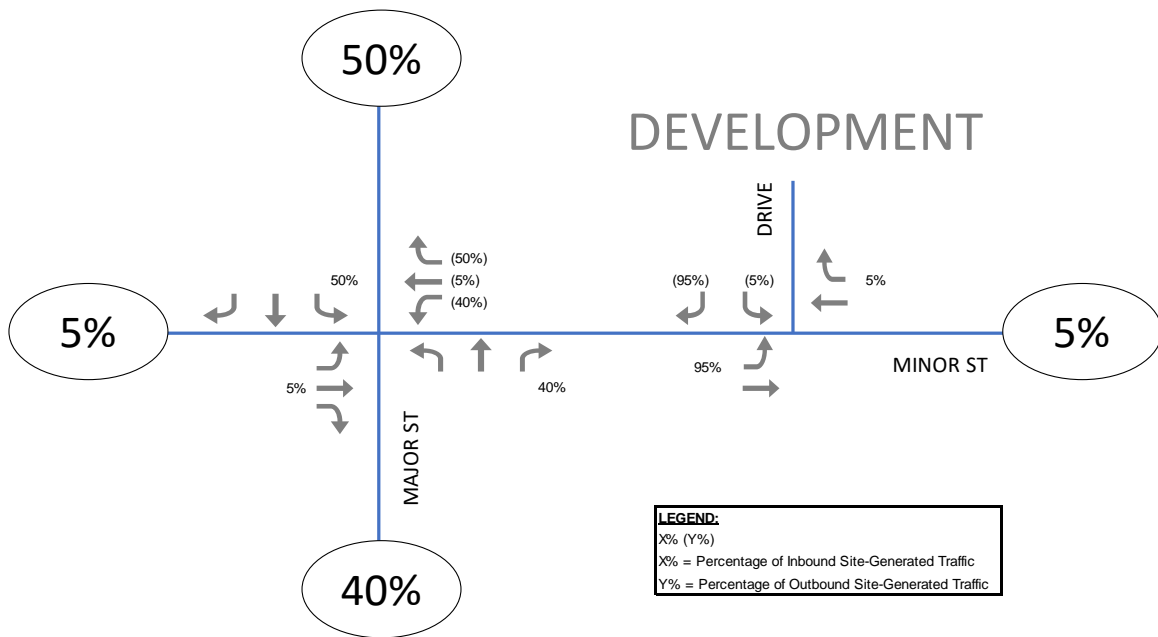

Figure 12-1. Trip Distribution Example Exhibit

12.4.1.4 Projecting Future Volumes and Conditions to be Analyzed

Background Growth

Based on the anticipated Build Out year, or phasing of the development, a compounding growth rate should be assumed to project background traffic. This growth rate should be considered based on historical data near the study area. Acceptable historical data sources include:

- [NCTCOG Traffic Count Data](#)
- [TxDOT Statewide Planning Map AADT](#)
- Raw traffic count data obtained from previously approved TIAs

Other Developments Near the Study Area

Prior to submitting the Methodology Memo, the TIA preparer is to inform TPW of the proposed development study location. If TPW determines that site traffic from other planned developments should be accounted for in the TIA, then TPW is to provide the TIA preparer with a copy of the completed TIA for those developments.

Impact of Future Connections

If TPW determines that the project is anticipated to provide an additional thoroughfare connection with the potential to impact the routing of existing, non-site traffic, this potential change should be accounted for in the future traffic volumes.

12.4.1.5 Special Site Related Topics

If the TIA preparer or TPW has any site-specific topics they feel need to be addressed, these are to be included in the Methodology Memo. TPW is to include these site-specific topics with the review of the TIA Determination Worksheet. These topics may include, but are not limited to:

- Proposed road closures or right-of-way abandonment.
- The proposed addition, removal, or modification of on-street parking.
- Internal circulation procedures for schools or sites with heavy truck traffic.

12.4.2 TIA Contents

The focus of a TIA is on the impact of the site to the proposed site access drives and major intersections in the study area. In order to provide consistency and to facilitate staff review of traffic studies, the following should be used for a TIA, at a minimum:

12.4.2.1 Executive Summary

This section should contain a brief overview of the purpose of the study, location of the site, site description, site access, and land use. The study scenarios considered should be listed out. The key results of the study should be presented, including principle findings, conclusions, identified study area recommendations, and the scenario in which the recommendations are warranted. A recommendations exhibit should be provided showing all study area recommendations. An additional recommendations table should be provided stating each recommendation, its corresponding development phase, and the responsible party (see section **12.4.2.11** for information on mitigation requirements.)

12.4.2.2 Table of Contents

A table of contents should be provided that identifies sections of the TIA, along with a list of tables and figures.

12.4.2.3 Introduction

This section should contain a brief overview of the purpose of the study, location of the site, and land use. The study methodology should also be summarized stating what tools were used to complete the analysis (Synchro, SIDRA, etc.) and the study scenarios considered.

12.4.2.4 Existing and Proposed Site Uses

This section describes the current conditions and land uses at the site. A vicinity map should be provided showing the study area and proposed site access locations.

Site build out and adjacent unconstructed development information including land uses and intensities phasing dates, and project access locations and functionality should be included. A reference to an attached site plan should be provided.

12.4.2.5 Existing and Proposed Transportation System

Thoroughfares

Each thoroughfare being considered in the analysis should be described in the existing condition. The cross section, speed limit, and number of access connections proposed along the facility should be included. For any thoroughfare included in the MTP, a statement of whether the roadway is built out to its ultimate section is required.

Figure 12-2 provides an example Existing Lane Use and Traffic Control exhibit to be included in this section. Note, all study area intersections included in the analysis should be shown.

Any future adjacent projects and a brief description that will impact the study area network are to be included in this section.

The existing traffic volumes are to be presented similar to Figure 12-3. The date of data collection should be referenced.

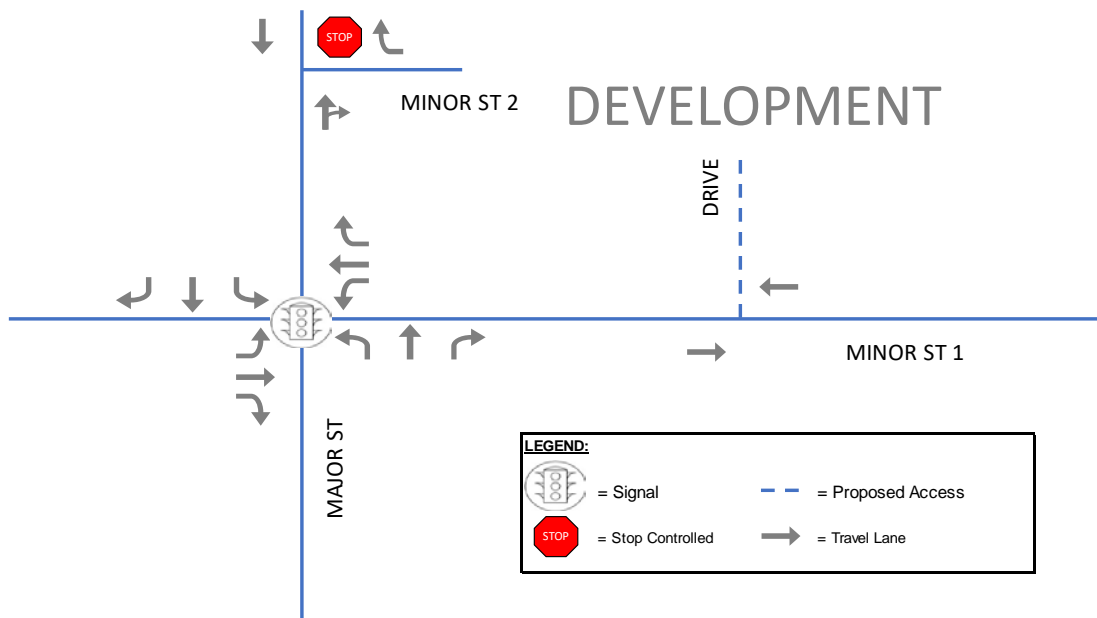

Figure 12-2. Existing Lane Assignment and Traffic Control Example Exhibit

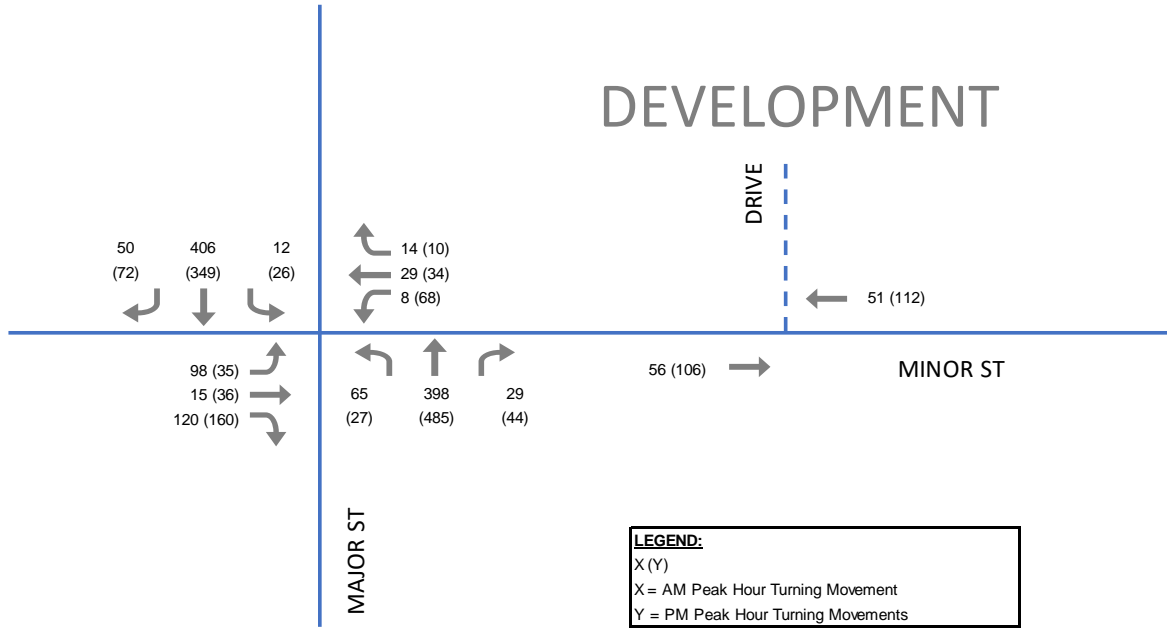

Figure 12-3. Existing Traffic Volumes Example Exhibit

Transit Routes

This section is to identify any transit routes and stops that are near the study area. Refer to the [Active Transportation Plan](#) and [The Transit Master Plan](#) for additional guidance.

Bicycle Facilities

This section is to identify any existing or planned trail or on-street bike facilities that are within the study area. Additionally, a discussion of each of the major thoroughfares within the study area and the bike lane or sidepath component included in the ultimate cross section should be discussed.

Pedestrian Connections

This section is to identify any existing pedestrian connections within the study area. If there are schools near the study area, consideration should be given to provide sidewalks, trails, or other pedestrian facilities to complete connectivity to the surrounding schools.

12.4.2.6 Trip Generation

The proposed development’s daily and peak hour trip generation should be presented. Each peak hour to be analyzed should be included in the table. Any impacts due to pass-by or internal capture should be included. If the development is anticipated to have phases, these should be outlined as well.

Table 12-3 provides an example for the trip generation rates or equation table to be provided. Note that the determination of when to use trip generation equations versus rates should be considered based on the number of studies performed by ITE and the development intensity.

Table 12-3. Trip Generation Rates/Equation Example Table

Land Use Description	Daily		Peak Hour	
	Equation/Rate	In/Out Split (%)	Equation/Rate	In/Out Split (%)
Single Family	9.44 / $\text{Ln}(T) = 0.92\text{Ln}(X) + 2.71$	50/50	0.99 / $\text{Ln}(T) = 0.96\text{Ln}(X) + 0.20$	63/37

See **Table 12-2** for an example trip generation table. This table applied the development intensity to the trip generation rates, or equations, to yield to anticipated development’s trip generation.

12.4.2.7 Trip Distribution and Traffic Assignment

The proposed development’s directional distribution of site traffic should be presented following the outline presented in section 12.4.1.3.

12.4.2.8 Background Growth Rate

The compounding growth rate for the study area to accommodate for background growth should be presented along with data to show the calculation performed when determining the growth rate. Any unusual fluctuations in historical growth should be considered, such as the impact of construction along a parallel corridor for a period of time. It is recommended to use at least five years of data. **Table 12-4** provides an example of what this table should look like. When historical data is not available, a minimum background growth rate of 3.0% can be used as a default. A growth rate must be agreed upon between the City and developer.

Table 12-4. Background Growth Rate Calculation Example Table

Main St, South of 1 st Street	Traffic Volume (vpd)	Annual Growth Rate
2015	2,000	-
2016	2,050	2.5%
2017	1,995	-2.7%
2018	2,100	5.3%
Average Growth Rate		1.7%

12.4.2.9 Study Scenarios

Below are the typical study scenarios to be included in a TIA.

- Existing
- Build Out Year without Site Traffic
- Build Out Year with Site Traffic

The Build Out year shall be established in the Methodology Memo. Additional scenarios may be required for multi-phase developments or other circumstances, as determined to be necessary by TPW. A background scenario should be included for any phased scenario included in the TIA.

12.4.2.10 Traffic Operations Analysis

Intersection Analysis

This section should reiterate the study scenarios which analysis will be completed for as well as the programs anticipated to be utilized in reporting level of service (LOS). The target LOS

identified for the City is LOS D. A table that breaks out each LOS and corresponding delays should be provided. An intersection analysis using a City approved intersection control evaluation tool may be required at the discretion of TPW.

When reporting LOS, the model should account for overall intersection peak hour factors (PHF) observed in the field unless the traffic volumes in the future are anticipated to dramatically change. If this is the case, this should be noted along with the assumed PHF.

Table 12-5 provides an example of the intersection capacity analysis table that should be provided for each study scenario. For signalized or roundabout intersections, the approach and overall LOS are to be presented. For stop-controlled intersections, the LOS of the stop-controlled approaches are to be reported. A separate table is recommended for the AM and PM peak hour analysis (and any additional or alternate time periods, if applicable).

For any intersection or approach anticipated to operate at LOS E or worse, some mitigation measure is required which brings the intersection or approach back to within acceptable LOS.

TPW can request additional measures of effectiveness to be reported such as 95th percentile queue lengths or V/C ratios.

Table 12-5. Intersection Capacity Analysis Example Table

Intersection	Approach	Scenario A		Scenario B	
		Delay (s/veh)	LOS	Delay (s/veh)	LOS
Signalized					
Main St & 1 st St	EB	9.5	A	86.4	F
	WB	8.6	A	20.9	C
	NB	36.7	D	52.4	D
	SB	47.6	D	54.6	D
	<i>Overall</i>	<i>20.1</i>	<i>C</i>	<i>49.4</i>	<i>D</i>
Unsignalized					
Main St & 2 nd St	WB	15.6	C	54.6	F

Each study scenario should include a brief description of the traffic volumes utilized and modifications to the network. After this description, each instance of failing LOS is to be noted along with any mitigation coming from the particular scenario. These mitigation measures are to be carried over to the following scenarios to show the acceptable LOS can be achieved. If it is found that the final “Build Out” scenario observes failing LOS, an additional “Mitigated Build Out” scenario is recommended showing the mitigation measures and the anticipated resulting LOS.

Thoroughfare Capacity Analysis

This section is to be included if any of the study area thoroughfares are anticipated to be nearing capacity. The thoroughfare capacity analysis should be completed using criteria outlined by the North Central Texas Council of Governments (NCTCOG) which define capacity based on the setting of the roadway and cross section. **Table 12-6** provides an example of the thoroughfare capacity analysis that should be provided.

Table 12-6. Thoroughfare Capacity Analysis Example Table

Thoroughfare	Direction	Peak Hour 1			Peak Hour 2		
		Vol	V/C Ratio	Traffic Condition	Vol	V/C Ratio	Traffic Condition
Main St	NB	857	0.95	Tolerable	803	0.89	Tolerable
	SB	1,101	1.22	Failing	545	0.61	Acceptable
	Overall	1,958	1.09	Failing	1,348	0.75	Tolerable

The following are the breakdown for the traffic condition:

- $0.00 > V/C > 0.65 = \text{Acceptable}$
- $0.65 \geq V/C > 1.00 = \text{Tolerable}$
- $V/C \geq 1.00 = \text{Failing}$

No recommendations are needed unless the anticipated traffic condition is Failing.

12.4.2.11 *Mitigation*

The TIA should provide a section detailing the mitigations required for the study area intersections and roadway links to operate at an acceptable level of service. This section should also indicate the timeframe when mitigations are needed.

Non-Adjacent Facilities

Mitigations identified for facilities which are not adjacent to the development are not required for approval of the project but should be identified in the TIA for project planning and prioritization purposes with respect to transportation impact fees and other City funds.

Adjacent Facilities

Mitigations identified for facilities adjacent to the property boundary of the site may be required to be built by the development through a Community Facilities Agreement (CFA) with the City.

Table 12-7 provides guidance for when specific mitigations may be required and the minimum acceptable operating condition after mitigation.

Table 12-7. Mitigation Requirements

Location	Mitigation Measure	When Required	Minimum Operating Condition at Buildout
Site access drives	Left-Turn Auxiliary Lane	**	N/A
	Right-Turn Auxiliary Lane		
Thoroughfare Network Study Area Intersections	Traffic Signal	Intersection meets one or more Traffic Signal Warrants	LOS D
	Left-turn lane	**	OR
	Right-turn lane	**	Equal to existing delay if LOS E or F
Thoroughfare Network Study Area Roadway Links	Roadway Widening*	Widen roadway if $V/C \geq 0.80$	V/C < 0.80
		Consideration for widening if $V/C < 0.80$ and not built to ultimate MTP configuration	
Study Area Pedestrian Network	Provide pedestrian routes with associated infrastructure to schools	School within 0.25 miles of development	N/A

*Widening or new construction of roadways required by the development must be in conformance with Chapter 212 of the Texas Local Government Code.

**Refer to the [Access Management Policy](#) for requirements.

Table 12-8 provides an example of what the mitigation or recommendation table should look like.

Table 12-8. Mitigation Example Table

Scenario	Year	Recommendation	Responsible Party
Existing	2019	Signalize Main St & 1 st Street Intersection	City
Phase 1	2021	Eastbound Right-Turn Deceleration Lane at Drive 1	Development
Build Out	2023	Signalize Main St & 3 rd Street Intersection	Development

12.4.2.12 Sight Distance Analysis

Field observations should be made to confirm adequate sight distance at each proposed project access drive. A photolog for the intersection sight distance of each project access location is required. Sight distance should also be evaluated based on the ultimate cross section of the major street if future widening is anticipated.

Guidelines provided in AASHTO’s Green Book for intersection sight distance should be considered. The following movements should be considered for adequate sight distance:

- Left-turn from Stop (Case B1)
- Right-turn from Stop (Case B2)
- Left-turn from Major Road (Case F)

12.4.2.13 *Auxiliary Lane Analysis*

Each proposed project access drive or street should be evaluated for auxiliary lane needs at each phase anticipated of development. When analyzing for auxiliary lanes, existing traffic, background traffic, and site traffic should be considered.

Criteria for determining the need for left and right-turn auxiliary lanes is provided in **Chapter 4** of the [Access Management Policy](#).

12.4.2.14 *Access Spacing*

The proposed project access locations are subject to the spacing criteria from the City's [Access Management Policy](#). Spacing criteria is subject to the street type ([MTP](#) classification) and includes spacing between driveways, signals, roundabouts etc. Requests for deviations from the Access Management Policy and justifications for the deviations are to be included in the study.

12.4.2.15 *Conclusions and Recommendations*

This section is to include all the study area mitigation measures recommended in the report. Each measure should be included in the appropriate study scenarios header.

Additional sections are to be added including the findings of the auxiliary lane analysis, access spacing analysis, and any other transportation

City of Fort Worth TIA Determination Worksheet

Complete this worksheet required as specified in the City of Fort Worth's Transportation Engineering Manual Chapter 12 Section 3.

Section 1 - General Information	
Project Name:	Date:
Subdivision Plat Name:	Project Address/Location:
Owner Name:	Owner Email:
Owner Address:	Owner Phone:
Preparer Company:	
Preparer Name:	Preparer Email:
Preparer Address:	Preparer Phone:
TIA Methodology Confirmation?	<input type="checkbox"/> Yes, date: <input type="checkbox"/> No
TIA Submittal Type	
<input type="checkbox"/> TIA Determination Worksheet Only - Less than 100 peak hour trips	<input type="checkbox"/> TIA (500 + peak hour trips)
<input type="checkbox"/> TIA Determination Worksheet Only - Previous TIA Report Approved*	<input type="checkbox"/> Special Circumstances - TPW Request
<input type="checkbox"/> Methodology Memo - Prior to TIA Submittal	

Section 2 - Proposed Land Use and Trip Information									
	Land Use	ITE Code	ITE Unit	Intensity	Daily Trips	AM Peak Hour Trips		PM Peak Hour Trips	
						In	Out	In	Out
1									
2									
3									
4									
5									
6									
7									
8									
9									
10									
Total:									

Section 3 - Intersections to be Evaluated	
<input type="checkbox"/>	None required (TIA determination worksheet only)
<input type="checkbox"/>	Site access drives + thoroughfare and collector Intersections within 1 mile (TIA)
<input type="checkbox"/>	Additional intersections (identified by TPW):
1	
2	
3	
4	
5	
6	

Section 4 - Approved TIA Worksheet	
Project Name:	
Preparer Company:	Preparer Name:
Approved?	<input type="checkbox"/> Yes, by: <input type="checkbox"/> No, comments:

* If within two (2) years of approval date and one (1) of the following:

- 1) Within 10% of the peak hour trips of previously planned development
- 2) Within 100 peak hour trips of previously planned development