

# Checklist for Commercial Occupancy Change of Use



Online submittal via Accela Citizen Access only requires one of each of the following:

<https://aca-prod.accela.com/CFW>

## Building Permit Application

Building Floor Plans, drawn to scale, showing the existing space and any proposed alterations.

Use Verification Form. **(2 Pages)**

[www.fortworthtexas.gov/files/assets/public/development-services/documents/applications-forms/commercial-permit-use-verification-form-042722.pdf](http://www.fortworthtexas.gov/files/assets/public/development-services/documents/applications-forms/commercial-permit-use-verification-form-042722.pdf)

Change of Use (with or without Remodel) Questionnaire

[www.fortworthtexas.gov/files/assets/public/development-services/documents/applications-forms/commercial-permit-questionnaire042022.pdf](http://www.fortworthtexas.gov/files/assets/public/development-services/documents/applications-forms/commercial-permit-questionnaire042022.pdf)

Site Plan (*Grading Plan are not acceptable substitution for a site plan*)

Including all of the following:

- Property lines.
- Building location (dimensions to other structures, property lines, easements, etc.).
- Suite location.
- Accessory buildings, fences, enclosures, etc.
- Fire lane.
- Public streets.
- Existing or proposed fire hydrant location.
- Gas well setbacks (if applicable).
- Bike racks.
- Existing parking.
- Proposed parking allocated for the business.

Utility Site Plan *-only required if new water or sewer service lines are needed for the development*

Including all of the following:

[www.fortworthtexas.gov/departments/water](http://www.fortworthtexas.gov/departments/water)

- Clearly identified existing and proposed water/sewer services, with size and use (such as domestic, irrigation, fire line, public hydrant, sewer tap, etc.).
- Clearly identified existing services to be abandoned.
- Measurements from the nearest property line corner to each proposed service.
- Location of water services to be provided.
- Backflow preventer's.
- Grease trap (contact pretreatment services for application).
- Pressure reducing valves, when necessary.

Existing Plumbing Plan - if no changes to be made.

**NOTE: If remodeling work needs to be done, the following items below (on page 2) will also be required!!**

## Following Items Required for Commercial Occupancy Change of Use if Remodeling work is needed.



Mechanical plans if changes to the heating, ventilation or air conditioning (*HVAC*) system will be made. If the building is 5,000 SQFT or greater, plans signed by a licensed professional engineer in the State of Texas are required. [TBPE Flow Chart](#) for when an engineer is required.

Plumbing plans if changes to the plumbing system will be made (*include the existing plumbing plan if no changes will be made*). If the building is 5,000 SQFT or greater, plans signed by a licensed professional engineer in the State of Texas are required. [TBPE Flow Chart](#) for when an engineer is required.

Copy of the Energy Code Compliance Document, if alterations to the building envelope, lighting, or mechanical systems to be made. [www.energycodes.gov](http://www.energycodes.gov)

TABS # \_\_\_\_\_ for projects \$50,000 and over. [www.tdlr.texas.gov/ab/ab.htm](http://www.tdlr.texas.gov/ab/ab.htm)

Electrical plans if changes to the electrical system will be made. If the building is 5,000 SQFT or greater, plans signed by a licensed professional engineer in the State of Texas are required. [TBPE Flow Chart](#) for when an engineer is required.

**For more information about Occupancy Change of Use Permits, please refer to the City of Fort Worth website: [www.fortworthtexas.gov/departments/development-services/permits/change-of-use](http://www.fortworthtexas.gov/departments/development-services/permits/change-of-use)**



City of Fort Worth  
Development Services Department  
Certificate of Occupancy Application

**Project Address:** \_\_\_\_\_ **Bldg/Suite/Unit#:** \_\_\_\_\_

**Legal Description:** Addition \_\_\_\_\_ **Block** \_\_\_\_\_ **Lot** \_\_\_\_\_

*(Apartments require a list of all addresses, number of units in each building, site plan, floor plan drawn to scale of any non-residential spaces, and pre-code inspections.)*

**Name of Business:** \_\_\_\_\_

**Proposed Business Use:** \_\_\_\_\_ **Previous Business Use:** \_\_\_\_\_

**Electricity Release:** ( Y / N )

**Previous Certificate of Occupancy Permit# (if known):** \_\_\_\_\_

**Zoning of Property:** \_\_\_\_\_ **Legal Non-Conforming (LNC#):** \_\_\_\_\_

**First Certificate of Occupancy after Annexation:** ( Y / N ) (If yes, copy of the Annexation letter is required)

**Mobile Vendor:** ( Y / N ) **License Plate Number For Mobile Vendor:** \_\_\_\_\_

**Site Contact Name:** \_\_\_\_\_

**Phone Number:** \_\_\_\_\_ **\*E-Mail Address:** \_\_\_\_\_

\*\*\*\*\*

**\* Please fill out the information below if a Change of Use Required:**

**Change of Use with Remodel:** Yes(If yes, complete the items below) \_\_\_\_\_ No \_\_\_\_\_ (If no, skip to Applicant Name & Signature)

**Total Cost of Construction with Materials & Labor:** \_\_\_\_\_

**Total Cost of Construction *not including* Mechanical/Electrical/Plumbing:** \_\_\_\_\_

**TABS # (if Cost of Construction is \$50,000 or more )::** \_\_\_\_\_

**City of Fort Worth Contractor Registration #:** \_\_\_\_\_

**Contractor's Business Name:** \_\_\_\_\_

**Phone Number:** \_\_\_\_\_ **\*E-Mail Address:** \_\_\_\_\_

**Plans Exam Contact Name:** \_\_\_\_\_

**Phone Number:** \_\_\_\_\_ **\*E-Mail Address:** \_\_\_\_\_

**Applicant Name (Printed):** \_\_\_\_\_

**Phone Number:** \_\_\_\_\_ **\*E-Mail Address:** \_\_\_\_\_

**Applicant's Signature:** \_\_\_\_\_ **Date:** \_\_\_\_\_

\*\*\*\*\*



**Development Services  
Use Verification Form**

The information requested below, and quantities thereof, are required for submittal with applications for New Commercial Building Permits, Certificates of Occupancy, and Change of Use permits. All such information must be completed before the above-mentioned permit application can be accepted for processing.

**CHECK ALL THAT APPLY**

**There will be alcohol sales.**

**There will be sales of tobacco, smoking, e-cigarettes or other related products.**

*\*a store that derives 90% or more of its gross annual sales from the sale of tobacco, cigarettes, smoking, and electronic smoking devices, or related products & accessories, and does not sell alcoholic beverages for onsite consumption. Retail smoke shops shall be prohibited within 300 feet of schools, universities and hospitals.*

**There will be outside sales and/or storage.**

**There will be gambling devices and/or any type of games of chance.**

**This is a Sexually Oriented Business** - If yes, describe Sexually Oriented Business

*\*Sexually Oriented Businesses include but are not limited to Adult Arcades, Adult Bookstores, Adult Video stores, Adult Cabarets, Adult Motels, Adult Motion Picture Theaters, Escort Agencies, Adult Modeling Studios, and Sexual Encounter Centers.*

**There will be auto-related uses including auto sales, auto repair, sales and/or installation of parts or accessories, car washes, and/or auto detailing.**

**There will be riveting.**

**There will be a landfill, recycling center, household hazardous waste facility, or waste tire facility.**

*\*Facilities handling, processing, and/or loading of municipal solid waste and recyclable material for transportation at transfer stations; storage, processing, bailing or reclamation of paper, glass, wood, metals, plastics, rags, junk, concrete, asphalt, and other materials at recovery facilities and recycling centers; disposal, dumping, or reducing of offal or dead animals; composting for yard and wood wastes, municipal solid waste, and/or sludge at composting facilities; collection and storage of scrap tires at waste tire facilities; are all subject to providing details as to Storage/Warehouse and/or Manufacturing Use(s) below:*

**There will be a Storage/Warehouse Use** - If yes, provide a detailed list of items or chemicals that will be stored. Additional information can be provided in the Use Verification Business Letter *(attached below)*:

**There will be Manufacturing** - If yes, provide information on the manufacturing process, and list the items being manufactured, as well as, the horsepower of the machinery below. Additional information can be provided in the Use Verification Business Letter *(attached below)*:

If stamping, dyeing, sheering, and/or punching metal, provide the thickness of metal:

\*\*\*\*\*

**Applicant Name (Print):** \_\_\_\_\_ **Date:** \_\_\_\_\_

**Applicant Signature:** \_\_\_\_\_ **Company Represented:** \_\_\_\_\_



**Development Services  
Use Verification Letter**

**The information requested below, and quantities thereof, are required for submittal with applications for New Commercial Building Permits, Certificates of Occupancy, and Change of Use permits. All such information must be completed before the above-mentioned permit application can be accepted for processing.**

**Business Name:** \_\_\_\_\_

**Type of Use(s):**  
\_\_\_\_\_  
\_\_\_\_\_  
\_\_\_\_\_  
\_\_\_\_\_  
\_\_\_\_\_  
\_\_\_\_\_

**Additional Manufacturing/ Storage or Warehousing Information:**  
\_\_\_\_\_  
\_\_\_\_\_  
\_\_\_\_\_  
\_\_\_\_\_

**Number of Employees:** \_\_\_\_\_

**Hours of Operation (For Game Room Applicants Only):** \_\_\_\_\_ **to** \_\_\_\_\_

**Applicant Name (Print):** \_\_\_\_\_

**Phone:** \_\_\_\_\_

**Applicant Signature:** \_\_\_\_\_

**Date:** \_\_\_\_\_



## Development Services

### Commercial Remodel / Change of Use Questionnaire

Address: \_\_\_\_\_

Please circle the correct answer to each question below and provide details for all "yes" answers.

1. Does your project involve an addition or alteration to a drive thru, truck dock, loading zone, dumpster enclosure, or head-in parking? (T/PW)  
No  
Yes, Please Explain \_\_\_\_\_
2. Does your scope of work involve changes to a Day Care Center, Hotel/Motel, or Retirement Center, and/or does it have a commercial kitchen? (Health, Backflow, Grease Trap)  
No  
Yes, Please Explain \_\_\_\_\_
3. Does your project involve an addition or alteration to the parking lot, side walks, curb ramps, or drive approach? (T/PW)  
No  
Yes, Please Explain \_\_\_\_\_
4. Does your project involve the addition of a fire sprinkler system or landscape irrigation system? (Water)  
No  
Yes, Please Explain \_\_\_\_\_
5. Does your scope of work involve changes to a restaurant, catering kitchen, grocery store, Bar/Lounge, or other food operation that will serve food to the public, or if already established, are you increasing capacity? (Health, Backflow, Grease Trap)  
No  
Yes, Please Explain \_\_\_\_\_
6. Do you discharge any industrial operation wastewater into the sanitary sewer and/or do you have an electric traction or hydraulic elevator? (Grease Trap)  
No  
Yes, Please Explain \_\_\_\_\_
7. Are there any plumbing connections to fixtures other than standard restroom fixtures, hand sink(s), or drinking fountain(s)? (Backflow)  
No  
Yes, Please Explain \_\_\_\_\_
8. Is this currently a single family residence or duplex that is changing to a commercial, industrial, or institutional use; such as a daycare, church, or community home? (Urban Forestry, Backflow, Grease Trap)  
No  
Yes, Please Explain \_\_\_\_\_
9. Are you removing any trees or adding/reconstructing any parking areas? (Urban Forestry)  
No  
Yes, Please Explain \_\_\_\_\_

Signature \_\_\_\_\_ Date \_\_\_\_\_

Print Name: \_\_\_\_\_

2/22/22 DB

VICINITY MAP

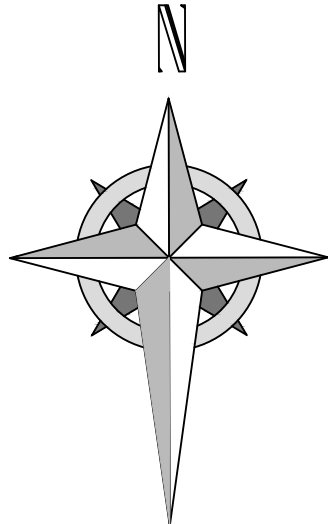
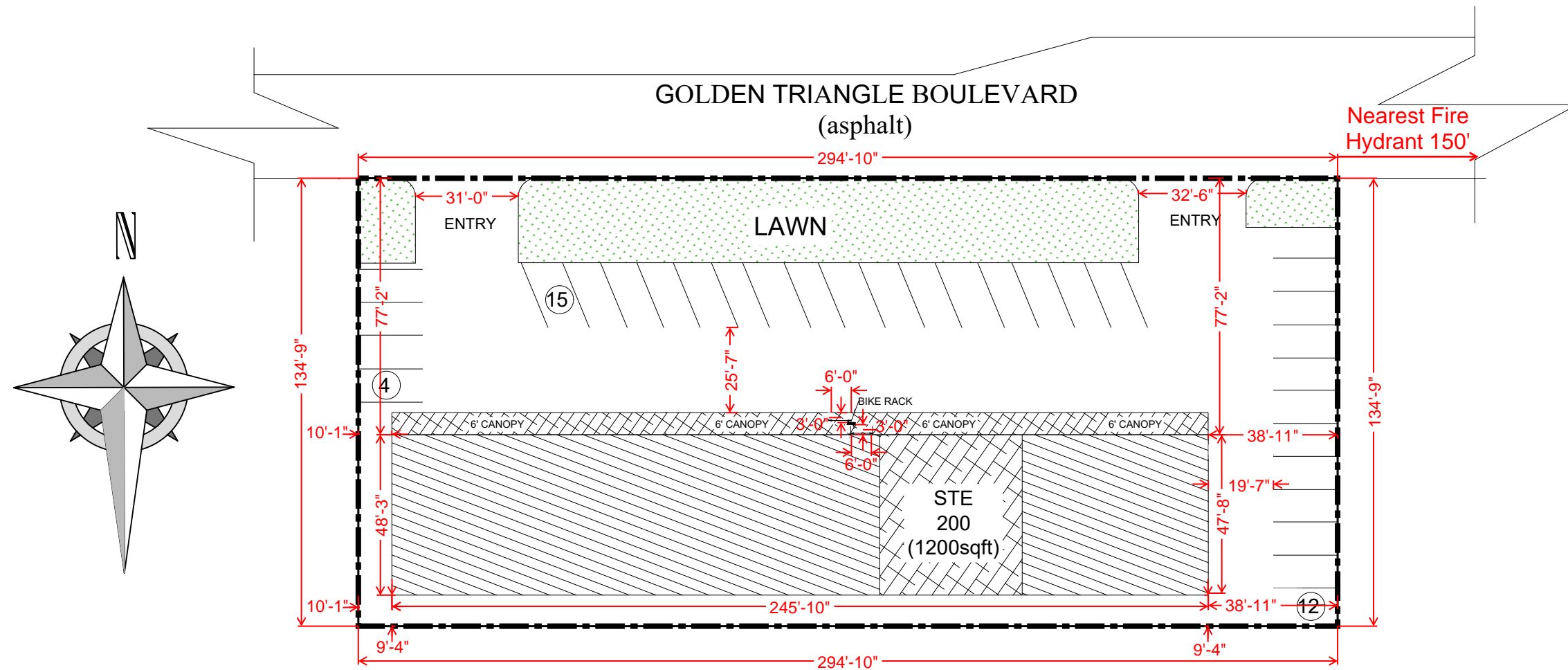

**SITE ADDRESS: 3588 Golden Triangle Blvd, Fort Worth, Texas**

PARKING LOT

|                         |    |
|-------------------------|----|
| PARKING SPACES PROVIDED | 32 |
|                         |    |
|                         |    |
|                         |    |
|                         |    |
|                         |    |
|                         |    |
|                         |    |

SHEET TITLE

**EXAMPLE SITE PLAN**

**CONSULTANT**

Architects, Planners & Project Managers  
817-123-4567  
Consultant@company.com

|            |                    |                        |            |
|------------|--------------------|------------------------|------------|
| ARCHITECT  | CONSULTANT         | SHEET NO.<br><b>01</b> |            |
| DRAWN      | CONSULTANT         |                        |            |
| CHECKED BY | CONSULTANT         |                        |            |
| SCALE      | 1" = 40" (11"x17") | DATE                   | MM-DD-YYYY |

SKU: 766br100  
 Variations:  
 766br100-84  
 766br100-85  
 766br100-86  
 766br100-87  
 766br100-88  
 766br100-89  
 766br100-90  
 766br100-91  
 766br100-92  
 766br100-93  
 766br100-94  
 766br100-95  
 766br100-96

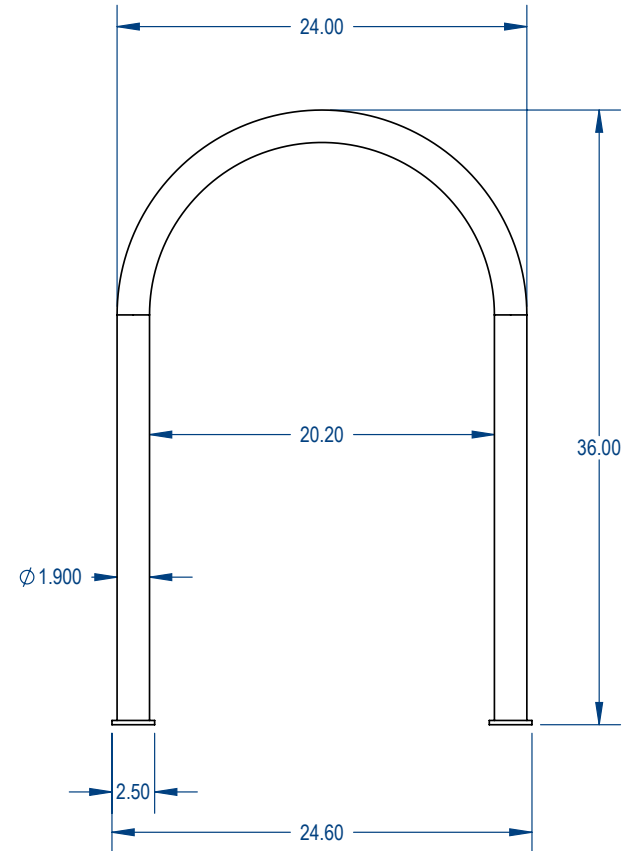
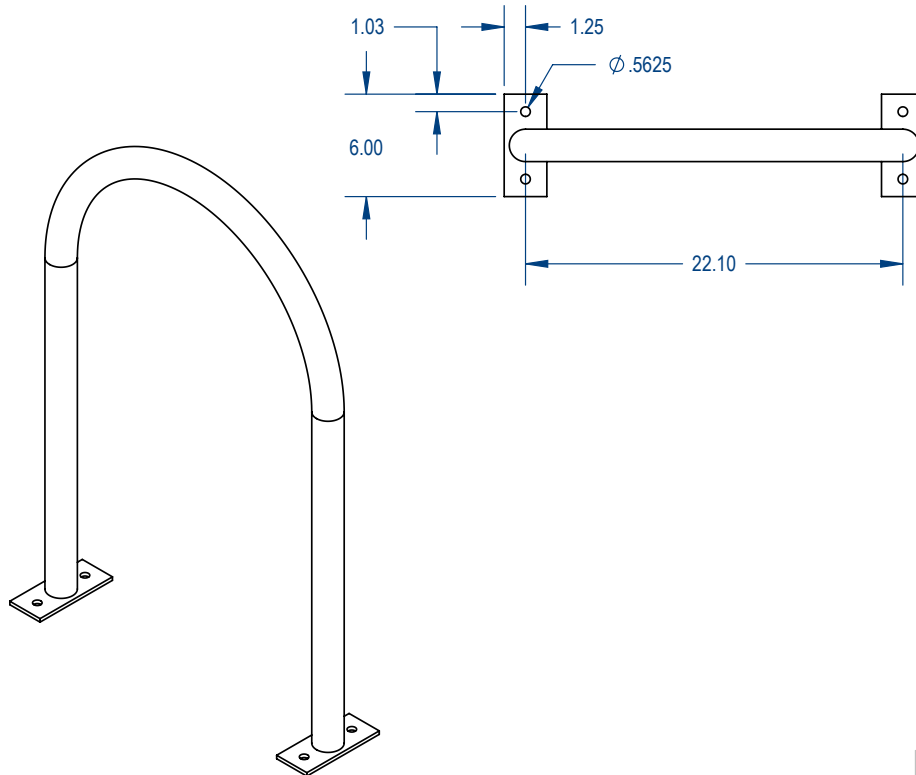

Manufactured For:

|              | NAME | DATE      | TITLE:   |          |     |
|--------------|------|-----------|--|----------|-----|
| DRAWN        | GM   | 1/26/2017 | <h1>Wide U-Bike Rack</h1> <h2>1.9" OD - Surface Mount Version</h2> |          |     |
| SALES APPR.  |      |           |  |          |     |
| CLIENT APPR. |      |           |  |          |     |
| MFG APPR.    |      |           |  |          |     |
| Q.A.         |      |           |  |          |     |
| Design By -  |      |           | SIZE   | DWG. NO. | REV |
|              |      |           | <b>A</b>   | 766br100 |     |
|              |      |           | WEIGHT:  |          |     |

5

4

3

2

1